

PUB00

Upright Bike

OWNER'S MANUAL



! CAUTION

Read all precautions
and instructions in this manual
before using this equipment

12P Rev C

! CAUTION

Read all precautions and instructions in this manual before using this equipment.

Table Of Contents

Important Safety Information -----	3
Warm Up Exercises -----	4
Parts List -----	5
Exploded View -----	7
Usage And Maintenance -----	9
Console Panel Functions -----	10
Troubleshooting Guide -----	15

Important Safety Instructions

Warning

The safety of the product can be maintained only if it is examined regularly for damage and wear. See preventive maintenance section for details.

Location

1. Keep the area around the product clear of any obstructions, including walls and furniture. Provide at least three feet of clearance behind the unit.
2. Do not use the product outdoors, near swimming pools, or in areas of high humidity.
3. Do not allow other people to interfere in any way with the user or equipment during workout.
4. Supervise closely any children or disabled persons using the product.

Operation

1. Always follow the console instructions for proper operation.
2. Do not reach into, or underneath, the unit; and do not tip the unit on its side during operation.
3. Never insert objects into any opening of the Bike. If any object fall into this equipment, carefully retrieve it while the unit is not in use. If the object can't be reached, please contact customer services.
4. Never place any containers filled with liquids on the unit, except in the accessory tray or water bottle holder. Containers should be covered with lids.
5. Wear shoes with rubber or high-traction soles. Do not wear shoes with high heels, leather shoes, slippers, or spikes. Make sure no sharp stuff is embedded in the soles.
6. Do not use the bike with bare feet.
7. Keep all loose clothing, shoelaces, and towels away from moving parts.
8. Take extra caution when stepping on or off the bike.
9. Never face backward while using the bike.

Save these instructions for future reference

Warm Up Exercises

EXERCISE GUIDELINES

WARNING! Before beginning this or any exercise program, you should consult your physician. This is especially important for individuals over the age of 35 or individuals with pre-existing health problems.

Warming up prepares the body for the exercise by increasing circulation, supplying more oxygen to the muscles and raising body temperature. Begin each workout with 5 to 10 minutes of stretching and light exercise to warm up. The photos on this page show several forms of basic stretching you may perform before your workouts. In order to achieve an adequate warm-up, perform each stretch three times.

TOE TOUCH STRETCH

Stand, bending your knees slightly and slowly bend forward from your hips. Allow your back and shoulders to relax as you reach down toward your toes as far as possible. Hold for 15 counts, then relax. This will stretch your hamstrings, back of knees, and back.

HAMSTRING STRETCH

Sit with one leg extended. Bring the sole of the opposite foot toward you and rest it against the inner thigh of your extended leg. Reach toward your toes as far as possible. Hold for 15 counts, then relax. This will stretch your hamstrings, lower back, and groin.

CALF/ACHILLES STRETCH

With one leg in front of the other, reach forward and place your hands against a wall. Keep your back leg straight and your back foot flat on the floor. Bend your front leg, lean forward and move your hips toward the wall. Hold for 15 counts, then relax. To cause further stretching of the achilles tendon, bend your back leg as well. This will stretch your calves, achilles tendons, and ankles.

QUADRICEPS STRETCH

With one hand against a wall for balance, reach back and grasp one foot with your other hand. Bring your heel as close to your buttocks as possible. Hold for 15 counts, then relax. This will stretch your quadriceps and hip muscles.

INNER THIGH STRETCH

Sit with the soles of your feet together and your knees outward. Pull your feet toward your groin area as far as possible. Hold for 15 counts, then relax. This will stretch your quadriceps and hip muscles.

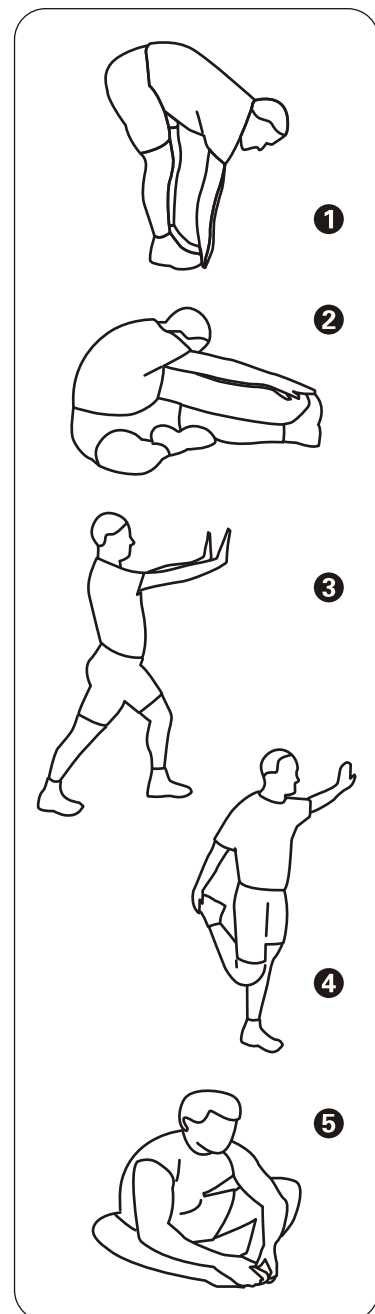

Parts List

Item No.	Description	Qty	Item No.	Description	Qty
1	Main Frame	1	24	Little Cover	1
2	Upright Frame	1	25	Shaft	1
3	Seat Post	1	26	Belt Pulley (8Groove)	1
4	Handle Bar	1	27	Pily-V Belt (420J8)	1
5	Connection Pole	1	28	Left Crank	1
6	Adjusting Pin	1	29	Right Crank	1
7	Adjusting Pole	1	30	Left Pedal	1
9	Front Base	1	31	Right Pedal	1
10	Rear Base	1	34	Tightener	1
11	Adjusting Handle Bar	1	35	Plate	1
12	Guide Sleeve	1	36	Hex Flange Screw	2
13	Guide Sleeve A	1	37	Plug For Crank	2
14	Screw Pin	1	38	Tightening Wheel	1
15	Leveler Foot	4	39	Bearing	2
16	PU Wheel	2	40	Bush	2
17	Pressure Spring	1	41	Adjusting Shaft	1
18	Pull Spring	1	42	Flat head rivet 6*20	1
19	Seat Pad	1	44	Shaft Clip Φ 20	2
20	Left Cover	1	45	Shaft Clip Φ 45	1
21	Right Cover	1	46	Undee Washer	1
22	Seat Left Cover	1	48	Hex Head Bolt M10*25	4
23	Seat Right Cover	1	49	Allen Pan Bolt M8*20	6

Parts List

Item No.	Description	Qty	Item No.	Description	Qty
50	Allen Pan Bolt M8*45	2	76	Nylon lock Nut M8	2
51	Pillip Screw M5*8	2	77	Pillip Screw ST4.2*13	8
52	Pillip Screw M6*12	3	78	Rivet	2
53	Pillip Screw M6*35	1	79	Rivet Nut M8	6
54	Flat Philips Screw M5*12	2	80	Washer $\Phi 6$	4
55	Pillip Screw ST4.2*16	12	81	Allen Bolt M8*40	1
57	Allen Bolt M5*10	4	82	Nut M8	2
58	Allen Bolt M6*15	8	83	Rivet	2
59	Allen Bolt M6*20	1	E1	Magnetic Force	1
60	Allen Pan Bolt M8*25	4	E2	PCB	1
61	Spring Washer $\Phi 6$	4	E3	Console Line 2	1
62	Spring Washer $\Phi 8$	4	E6	Console	1
64	Washer $\Phi 6.6 \times \Phi 18 \times 1.6$	1	E7	Hand Pules Circuitry Board	1
65	Washer $\Phi 9 \times \Phi 16 \times 1.6$	14	E8	Heartbeat Receiver	1
66	Washer $\Phi 11 \times \Phi 20 \times 2$	4	E9	Stopwatch	1
67	Nylon lock Nut M6	5	E10	Hand Pulse	2
69	Nut M6	1	E11	Console Line 1	1
70	Thin Nut M10	4	E12	Hand Pules Line	2
71	Flat Wrench	1	E13	Plastic Bush	4
72	Hex Wrench S=6	1	E14	Pillip Screw ST2.9*16	4
73	Hex Wrench S=5	1	E15	Overlay	1
74	Washer $\Phi 55 \times \Phi 45 \times 0.4$	1	E16	Console Logo Sticker	1
75	Plug	4			

Exploded View

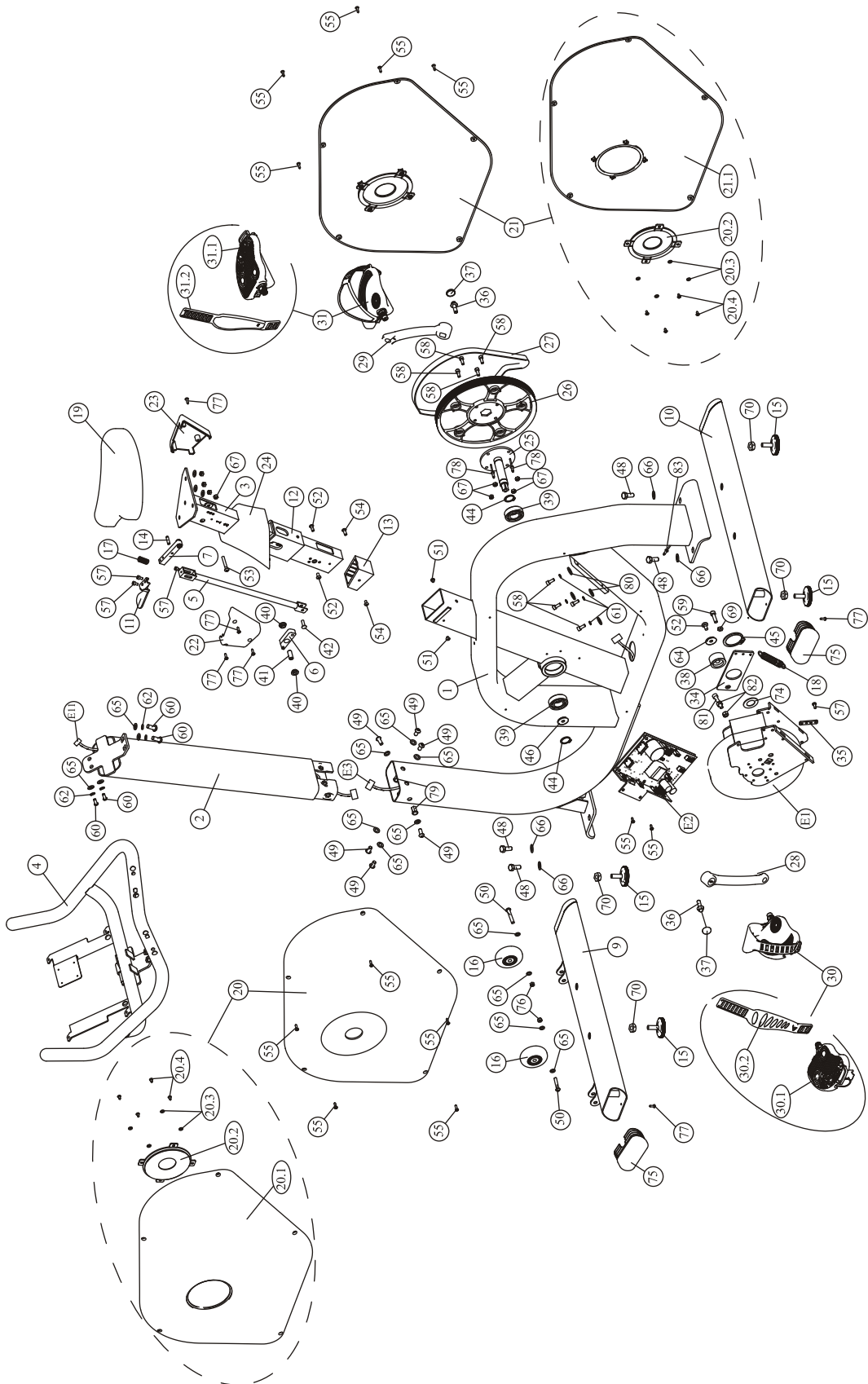

Exploded View

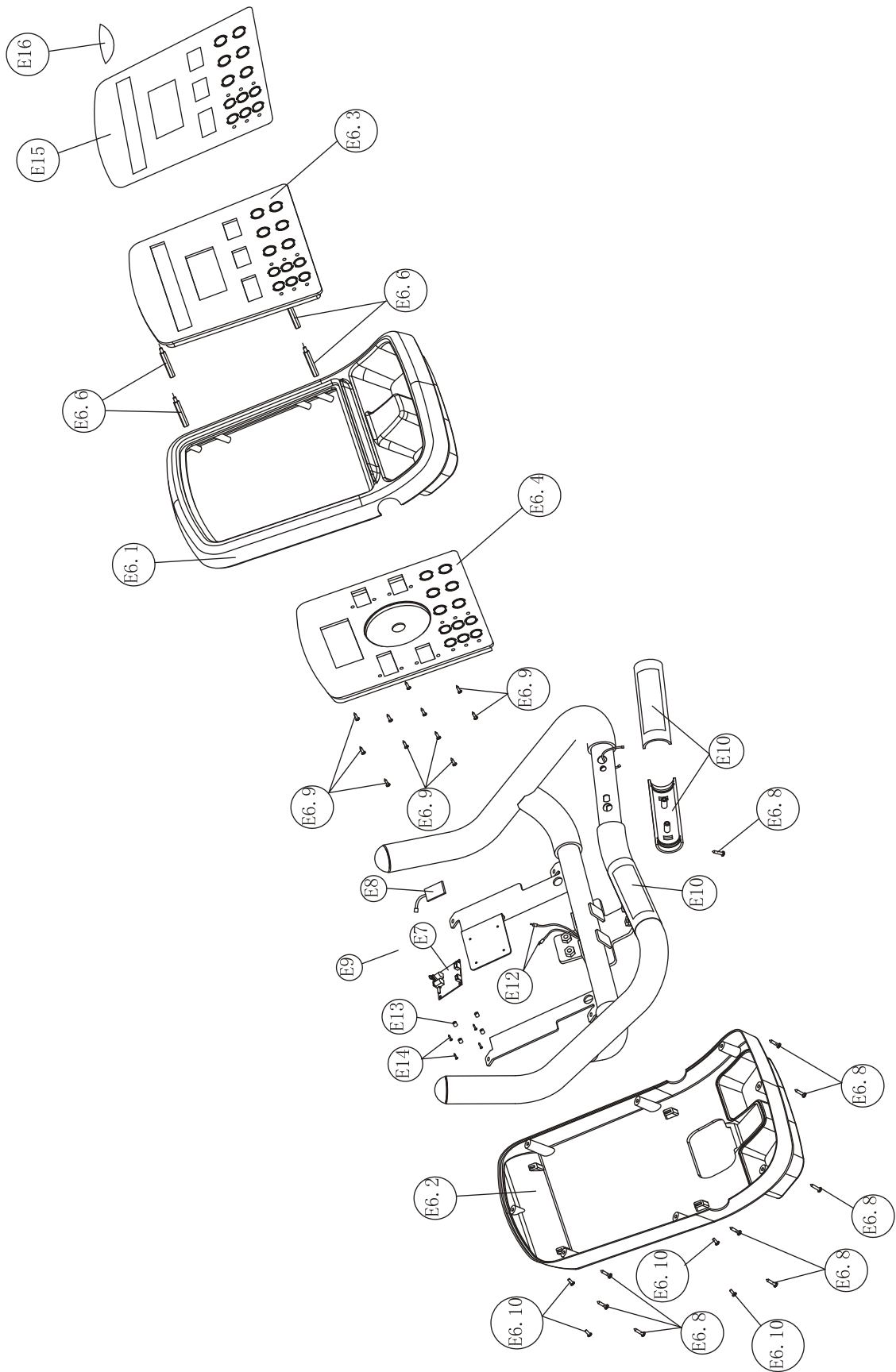

Usage And Maintenance

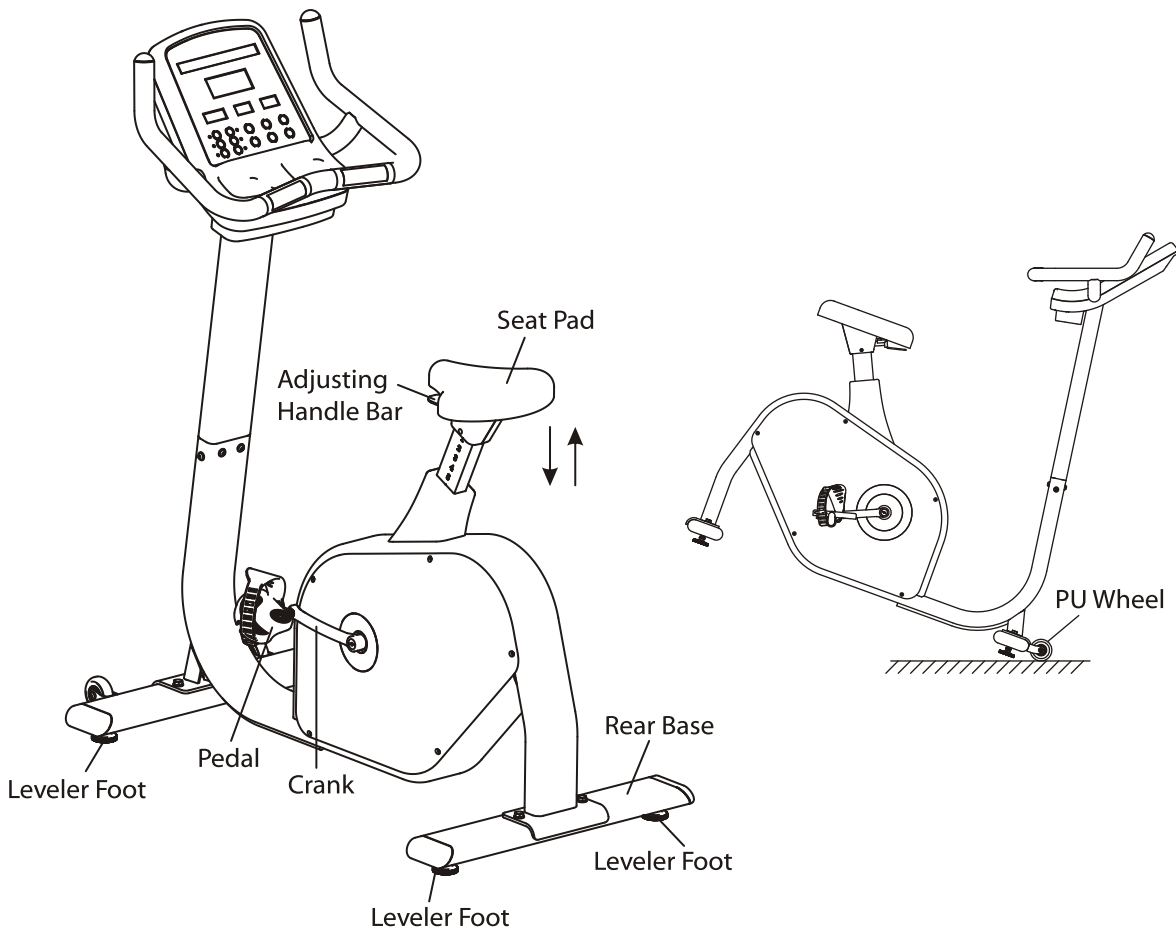

Instruction

1. Max. User Weight is 150 Kg.
2. When moving the machine, grasp the Rear Base, you can move it by the PU Wheel.
3. When using the machine, you must ensure it stand steadily on the ground. If it isn't steady, you must adjust the Leveler Foot.
4. Adjusting the seat pad support of the machine. When down, you must pull up the adjusting handle bar, and move the seat pad support down along the tube of the machine. When it is ok, you can lose you hands. When up, you can move the seat pad support up along the tube of the machine. When it is ok, you can lose you hands.
5. The machine has self-generating system (no power required).

Maintenance

1. Tighten the pedals every 3 months.
2. If the Bolts and Screws have the trend of losing, please lock them timely.

Console Panel Functions

DISTANCE

WATT

HEART RATE

CALORIE

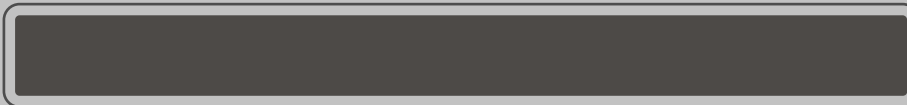

Quick Start:

- Start pedaling, press **(START)**.
- To manually adjust resistance, using **(UP)** **(DOWN)**.

Program Operation:

- Start pedaling, press program button.
- Using **(UP)** **(DOWN)** to enter message.
- Press **(START)** when START scrolling in the window.
- Using **(UP)** **(DOWN)** to change the resistance.
- Using **(MODE)** select time/distance/calorie countdown program.

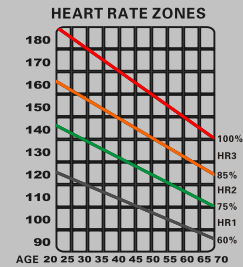

TIME

SPEED

LEVEL

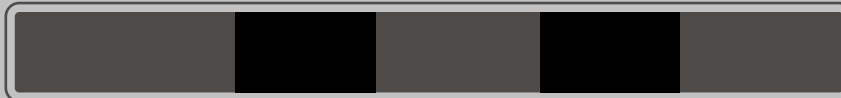

MANUAL CARDIO (UP) MODE (ENTER)

FATBURN HEART RATE (DOWN)

RANDOM USER (START) (STOP)

Console Panel Functions

CONSOLE PANEL FUNCTION



1. TIME WINDOW

Indicates elapsed time after pressing start in minutes and seconds (0-99minutes, 0-59seconds).

2. SPEED WINDOW

Indicates workout laps per minute on pedal.

3. LEVEL WINDOW

Indicates workout in degree of force L1—L20 in 1 increments.

4. HEART RATE WINDOW

Indicates user's current heart rate (BPM).



5. DISTANCE WINDOW

Indicates Kilometers or Miles traveled in 0.01 increments up to 9.99 and 0.1 increments starting at 10.0 (Range 0.01---999).

6. CALORIE WINDOW

Indicates estimated calories used based on 68 Kg person at the indicated speed, degree of force and time.

7. WATT WINDOW

Indicates user's current to make power (Watt).

8. DOT MATRIX

8.1 Indicates ENTER WEIGHT KGS (or Lbs) when turn on power.

8.2 Indicates message when enter value.

8.3 Indicates workout curve in Program mode.



CONSOLE BUTTONS

1. START

This button is used to start the current program.

2. STOP

This button is used to stop the current program.

3. LEVEL + and LEVEL -

These buttons are used to adjust the degree of force of the machine during workout.



These buttons are also used to adjust the values when setting up your workout.

4. MODE

This button is used to cycle through to the desired program (time countdown, calories countdown, distance countdown mode).

Console Panel Functions

5. ENTER



This button is used to enter value of program mode.

6. MANUAL ONE TOUCH



This button is used to select workout "manual mode".

7. FAT BURN ONE TOUCH



This button is used to select workout "fat burn mode".

8. RANDOM ONE TOUCH



This button is used to select workout "random mode".

9. CARDIO ONE TOUCH



This button is used to select workout "cardio mode".

10. HEART RATE ONE TOUCH



This button is used to select workout "heart rate mode".

11. USER ONE TOUCH



This button is used to select workout "user mode".

CONSOLE OPERATION

1. QUICK START / MANUAL MODE

1.1 Start the pedal

1.2 Indicates "ENTER WEIGHT KGS" in dot matrix, "68" will be flash in degree of force window, Use level of force + or – button to adjust user weight.

1.3 Press "ENTER", Indicates "PRESS START OR SELECT PROGRAM" in dot matrix.

- (1) If press START button through manual mode;
- (2) If press FAT BURN button through fat burn mode;
- (3) If press RANDOM button through random mode;
- (4) If press CARDIO button through cardio mode;
- (5) If press HEART RATE button through heart rate mode;
- (6) If press USER button through user mode.

1.4 If press MODE button to cycle through to time countdown, distance countdown, calories countdown mode.

1.5 If press STOP button will be reset.

Console Panel Functions

2. PROGRAM MODE

2.1 TIME COUNTDOWN MODE

Press MODE button to cycle through time countdown mode After enter weight.

- (1) Indicates TIME COUNTDOWN in dot matrix, Time window will be flash 30:00, Use level + or – button to adjust value;
- (2) Indicates ENTER TIME in dot matrix after 5 seconds;
- (3) Indicates PRESS START in dot matrix after press ENTER button.

2.2 DISTANCE COUNTDOWN MODE

Press MODE button to cycle through distance countdown mode After enter weight.

- (1) Indicates DISTANCE COUNTDOWN in dot matrix, Distance window will be flash "0.00", Use level + or – button to adjust value;
- (2) Indicates ENTER DISTANCE in dot matrix after 5 seconds;
- (3) Indicates PRESS START in dot matrix after press ENTER button.

2.3 CALORIES COUNTDOWN MODE

Press MODE button to cycle through calories countdown mode After enter weight.

- (1) Indicates CALORIES COUNTDOWN in dot matrix, Distance window will be flash "000", Use level + or – button to adjust value;
- (2) Indicates ENTER CALORIES in dot matrix after 5 seconds;
- (3) Indicates PRESS START in dot matrix after press ENTER button.

2.4 PROGRAM

2.4.1 FAT BURN

Press FAT BURN button

- (1) Indicates FAT BURN MODE in dot matrix, Time window will be flash "30:00", Use level + or – button to adjust value;
- (2) Indicates workout curve in dot matrix after 5 seconds;
- (3) Indicates ENTER TIME ENTER TIME in dot matrix after 5 seconds;
- (4) Indicates PRESS START in dot matrix after press ENTER button.

2.4.2 RANDOM

Press RANDOM button

- (1) Indicates RANDOM MODE in dot matrix, Time window will be flash "30:00", Use level + or – button to adjust value;
- (2) Indicates workout curve in dot matrix after 5 seconds;

Console Panel Functions

(3) Indicates ENTER TIME ENTER TIME in dot matrix after 5 seconds;

(4) Indicates PRESS START in dot matrix after press ENTER button.

2.4.3 CARDIO

Press CARDIO button

(1) Indicates CADIO MODE in dot matrix, Time window will be flash "30:00", Use level + or – button to adjust value;

(2) Indicates workout curve in dot matrix after 5 seconds;

(3) Indicates ENTER TIME ENTER TIME in dot matrix after 5 seconds;

(4) Indicates PRESS START in dot matrix after press ENTER button.

2.4.4 HEART RATE

User must wear chest belt when through HEART RATE mode

HR1: Target pulse is 65% of Max. pulse;

HR2: Target pulse is 75% of Max. pulse;

HR3: Target pulse is 85% of Max. pulse.

2.4.4.1 HR1

Press HEART RATE button to cycle through HR1, HR2, HR3

(1) Indicates HEART RATE 1 in dot matrix, Time window will be flash "30:00", Use level + or – button to adjust value;

(2) Indicates ENTER TIME in dot matrix after 5 seconds;

(3) Indicates ENTER AGE in dot matrix after press ENTER button, Pulse window will show target pulse;

(4) Indicates PRESS START after press ENTER button.

2.4.4.2 HR2-HR3

Press HEART RATE button to cycle through HR1, HR2, HR3, the same HR1

2.4.5 USER

Press USER button

(1) Indicates USER PROGRAM in dot matrix, Time window will be flash "30:00", Use level + or – button to adjust value;

(2) Indicates workout curve after 5 seconds;

(3) Indicates ENTER TIME after 5 seconds;

(4) Indicates ENTER RESISTANCE in dot matrix after press ENTER button, Level window will be flash;

(5) First segment will be flash, Using level + or – button to adjust value;

(6) Press ENTER through next segment;

(7) Finished 20 segments, Indicates PRESS START after press ENTER button.

Troubleshooting Guide

Malfunction	Probable Cause	Corrective Action
Heart rate reading is erratic or absent entirely	Belt transmitter electrodes are not wet enough to pick up accurate heart rate readings.	Wet the belt transmitter electrodes.
	Belt transmitter electrodes are not laying flat against the skin.	Ensure the belt transmitter electrodes are laying flat against the skin.
	Belt transmitter needs cleaning.	Wash the belt transmitter with mild soap and water.
	Belt transmitter is not within 3 feet (one meter) of the heart rate receiver.	Make sure the chest strap transmitter is within three feet (one meter) of the heart rate receiver.
	Chest strap battery is depleted.	Contact Customer Support Services for instructions on how to have the chest strap replaced.
Abnormally elevated heart rate readings	Electromagnetic interference from cell phones.	Move the cross-trainer a few inches away from the probable cause, or move the probable cause a few inches away from the cross-trainer, until the heart rate readings are accurate.
	Electromagnetic interference from computers.	
	Electromagnetic interference from cars.	
	Electromagnetic interference from high voltage power lines.	
	Electromagnetic interference from motor driven exercise equipment.	
	Electromagnetic interference from another heart rate transmitter within three feet (one meter).	

