



IT9510

LEG PRESS/CALF RAISE

OWNER'S MANUAL

17V

CAUTION! Read all precautions and instructions in this manual before using this equipment.

Table Of Contents

CAUTION!

Read all precautions and instructions in this manual before using this equipment.

Important Safety Instructions-----	3
Instructions-----	5
Exploded View and Parts List-----	6
Measurement Guide-----	19
Assembly Instructions-----	20
Assembly-----	21
Adjust Instructions-----	33
Exercise Instructions-----	34
Maintenance Schedule-----	35
General Maintenance Information-----	36
Weight Training Tips-----	37

Please assemble according to the actual **Weights** you buy !

Important Safety Instructions

Before beginning any fitness program, you should obtain a complete physical examination from your physician. When using exercise equipment, basic precautions should always be taken, including the following:

1. Read all instructions before using the equipment.
These instructions are written to ensure your safety and to protect the unit.
2. Use the equipment only for its intended purpose as described in this guide.
Do not use accessory attachments that are not recommended by the manufacturer: such attachments might cause injuries.
3. The product should only be used on a level surface and is with 0.5 meters space around the product.
Do not use the equipment outdoors.
4. Do not allow children on or near the equipment. And children are not allowed to use this equipment.
Teenagers should use this equipment with adult supervision.
5. Do not overexert yourself or work to exhaustion.
Do not attempt to lift more weight than you can control safely.
If you feel any pain or abnormal symptoms, stop your workout immediately and consult your physician.
6. This equipment is not used as medical apparatus and instruments.
7. Never operate the unit when it has been dropped or damaged.
Never drop or insert anything into any opening in the equipment.
Always check the unit and its cables before each use. Make sure that all fasteners and cables are secure and in good working condition.
Frayed or worn cables can be dangerous and may cause injury. Periodically check these cables for any indication of wear.
Keep hands, limbs, loose clothing and long hair well out of the way of moving parts.
8. Be careful when getting on or off the equipment.
9. Wear proper exercise clothing and shoes for your workout, no loose clothing.

Important Safety Instructions

Personal Safety During Assembly

Read each step in the assembly instructions and follow the steps in sequence. Do not skip ahead. If you skip ahead, you may learn later that you have to disassemble components and that you may have damaged the equipment.

Assemble and operate the equipment on a solid, level surface. Locate the unit a few feet from walls or furniture to provide easy access. The equipment is designed for your enjoyment. By following these precautions and using common sense, you will have many safe and pleasurable hours of healthful exercise with the equipment.

Training Area and Free Area

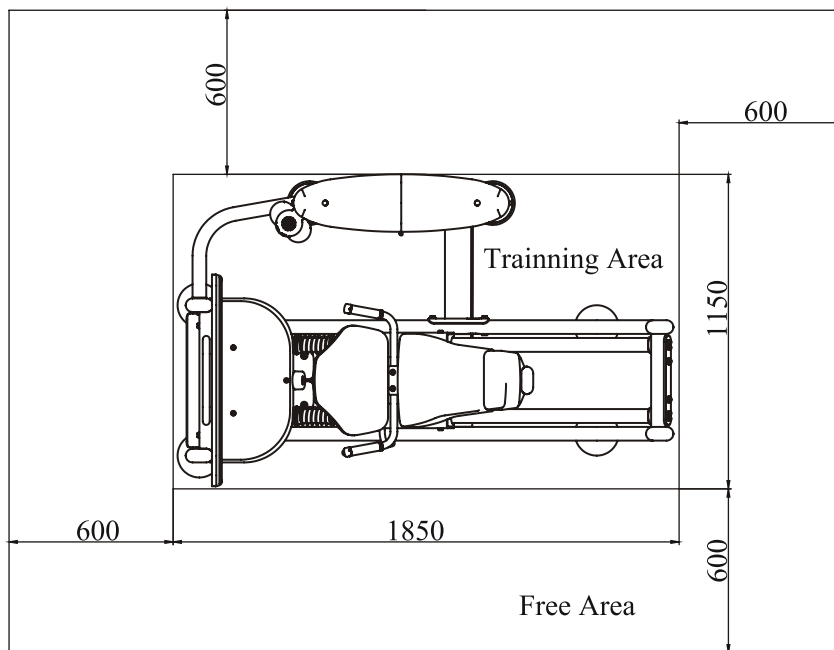

Specifications

Class: S

Maximum Wt. Capacity: 134kg/ 295lbs

Maximum User Weight: 150kg/ 330lbs

Product Total Surface: 1850*1150mm

Product Total Mass: 211.3kg/ 466lbs

Instructions

Before beginning assembly please take the time to read instructions thoroughly. Please use the various lists in this manual to make sure that all parts have been included in your shipment. When ordering, use part number and description from the lists. Use only our replacement part when servicing. Failure to do so will void your warranty and could result in personal injury.

The equipment is designed to provide the smoothest, most effective exercise motion possible. After assembly, you should check all functions to ensure correct operation. If you experience problems, first recheck the assembly instructions to locate any possible errors made during assembly. If you are unable to correct the problem, call your authorized dealer. Be sure to have your serial number and this manual when calling. When all parts have been accounted for, continue on.

Tools Required

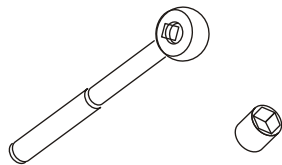

Ratchet Wrench and Socket

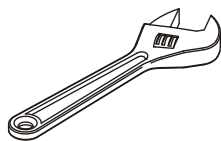

Adjustable Wrench

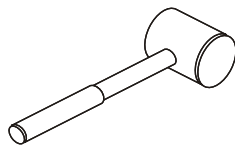

Rubber Mallet

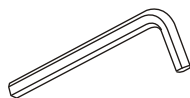

Hex Key Wrench Set

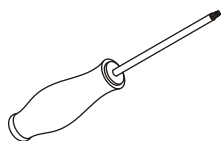

Phillips Screwdriver

Exploded View and Parts List

Overall

ItemNo.	Grade No.	Part No.	Description	QTY
1	1	IT951001ASSY	Weight Stack Frame ASSY	1
2	2	IT951002ASSY	Main Frame ASSY	1
3	3	IT95100300	Bottom Frame Brace	1
4	4	IT951004ASSY	Front Frame ASSY	1
5	5	IT95100500	Front Connection Frame	1
6	6	IT951005ASSY	Seat Carriage Frame ASSY	1
7	7	IT951006ASSY	Assist Grip Frame ASSY	1
8	8	IT951012ASSY	Front Pedal ASSY	1
9	9	IT95101000	Sliding Guide Rod	2
10	10	IT95101700	Connecting Plate	1
11	11	IT95101800	Cable ASSY	1
12	12	IT95101900	Big Spring	2
13	13	IT95102000	Nylon Baffle Ring	4
14	14	IT95081800	Seat Pad	1
15	15	IT950172ASSY	Head Pad ASSY	1
16	16	IT950171ASSY	Back Pad ASSY	1
17	17	IT95031200	Ellipse Plate	1
18	18	SG500110400V5	4.5" Pulley	3
19	19	SD1000B3000ASSY	Adjustable Foot Plate	4
20	20	IT801210300P11C	Cup Holder	1
21	21	IT950121ASSY	Top Bracket ASSY	1
22	22	IT950122ASSY	Bottom Bracket ASSY	2
23	23	IT95012300	Rear Bracket	1
24	24	IT95014200	Top Plate	1
25	25	IT95014400	Guide Rod ϕ 19*1242	2
26	26	IT95015100	Top Cover	1
27	27	IT95015200	Training Placard Cover	1
28	28	IT95015500	Top Rear Shroud	1
29	29	IT95015300	Front Shroud	1
30	30	IT95015400	Right Front Shroud	1

Exploded View and Parts List

Overall

Item No.	Grade No.	Part No.	Description	QTY
31	31	IT95015600	Rear Shroud	1
32	32	IT80023000	Weight Rubber Bumper	2
33	33	IT90012000V1	Selector Pin W/Coil	1
34	34	IT95016100	Guide Rod Fixing Sleeve ϕ 25* ϕ 19*45	2
35	35	HFOPT900-04A0602	Spring	2
36	36	IT95016500	Spout Plug ϕ 16.5*6.88	2
37	37	IT95031300	Support Sleeve	6
38	38	GB70BTM12*90DN18NL	Socket Head Cap Screw M12*90	2
39	39	GB70BTM12*80DN18	Socket Head Cap Screw M12*80	4
40	40	GB70BTM10*45DN18	Socket Head Cap Screw M10*45	2
41	41	GB70BTM12*30DN18	Socket Head Cap Screw M12*30	12
42	42	GB70BTM10*80DN18	Socket Head Cap Screw M10*80	6
43	43	GB70BTM10*75DN18	Socket Head Cap Screw M10*75	2
44	44	GB70BTM10*50DN18	Socket Head Cap Screw M10*50	3
45	45	GB70BTM10*30DN18	Socket Head Cap Screw M10*30	6
46	46	GB70M8*30*30DN19	Socket Head Cap Screw M8*30	4
47	47	GB70M8*20N19	Socket Head Cap Screw M8*20	2
48	48	GB818M6*20DHS2	Cross Recessed Pan Head Screw M6*20	18
49	49	GB818M6*16DHS2	Cross Recessed Pan Head Screw M6*16	4
50	50	GB818M6*10DHS2	Cross Recessed Pan Head Screw M6*10	4
51	51	GB9512DN2	Flat Washer ϕ 13* ϕ 24*2.5	14
52	52	GB9510DN2	Flat Washer ϕ 11* ϕ 20*2	24
53	53	GB958DN2	Flat Washer ϕ 9* ϕ 16*1.6	6
54	54	NM12DN2	Nylon Lock Nut M12	2
55	55	NM10DN2	Nylon Lock Nut M10	7
56	56	NBS6DHS	Hex Key S=6	1
57	57	NBS8DHS	Hex Key S=8	1
58	58	LW200BS	Wrench ϕ 6*117	1
59	59	YHY	Lube	1
60	72	CNLM8*20N19	Flat Head Cap Screw M8*20	3
61	71	IT95101600	Auxiliary Pedal	1
62	73	NBS5DHS	Hex Key S=5	1
63	74	GB9310N19	Washer ϕ 10	2

Exploded View and Parts List

Weight Stack Frame ASSY

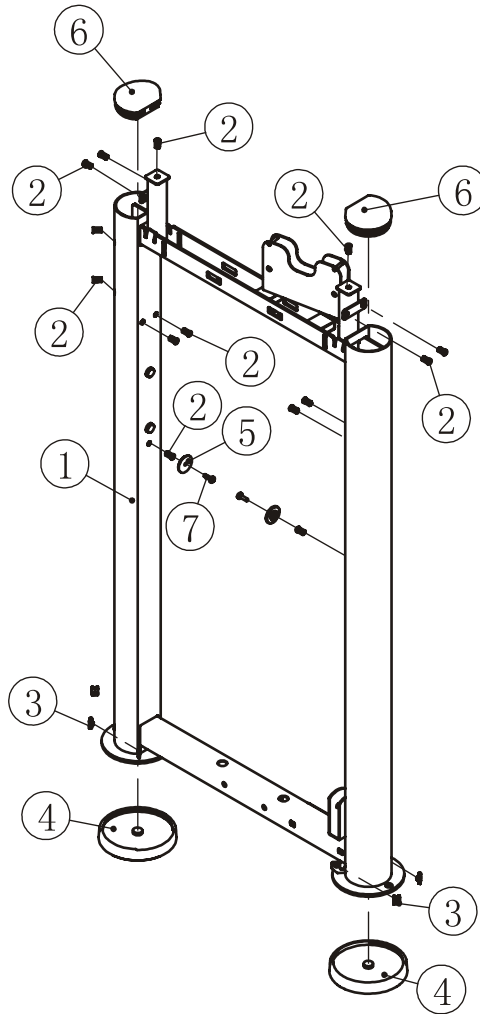

ItemNo.	Grade No.	Part No.	Description	QTY
1	1.1	IT95100100	Weight Stack Frame	1
2	1.2	GB17880.5M6*16.5DS17	Rivet Nut M6	14
3	1.3	AC32705800	U-nut M6	4
4	1.4	IT95015700	Foot Plate	2
5	1.5	IT95015900	Plastic Block	2
6	1.6	IT95015800	Plug ϕ 95*81.1	2
7	1.7	GB818M6*20DHS2	Cross Recessed Pan Head Screw M6*20	2

Exploded View and Parts List

Main Frame ASSY

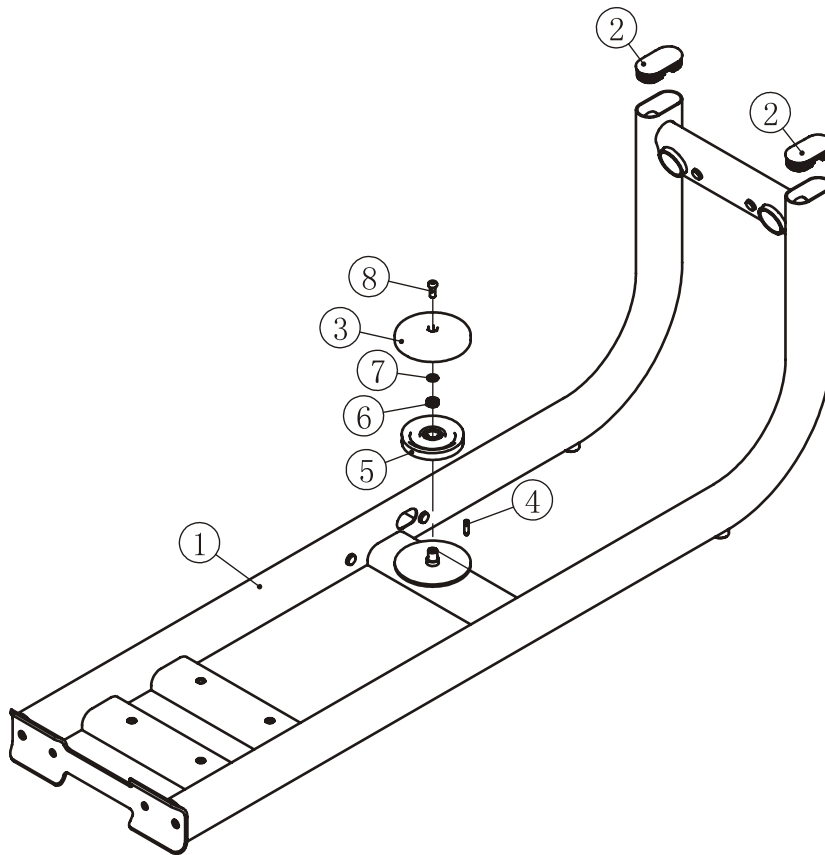

ItemNo.	Grade No.	Part No.	Description	QTY
1	2.1	IT95100200	Bottom Frame	1
2	2.2	IT90013800P11C	Plug RT50*100	2
3	2.3	IT95016400	Pulley Cover	1
4	2.4	FE97122300	Limit Shaft	1
5	2.5	IT95057800	4.5" Pulley	1
6	2.6	FE97122100	Bushing $\phi 22 * \phi 17.5 * 7.5$	1
7	2.7	DQ10N19B	Flat Washer $\phi 11 * \phi 25 * 2$	1
8	2.8	GB70BTM10*25DN18	Socket Head Cap Screw M10*25	1

Exploded View and Parts List

Front Frame ASSY

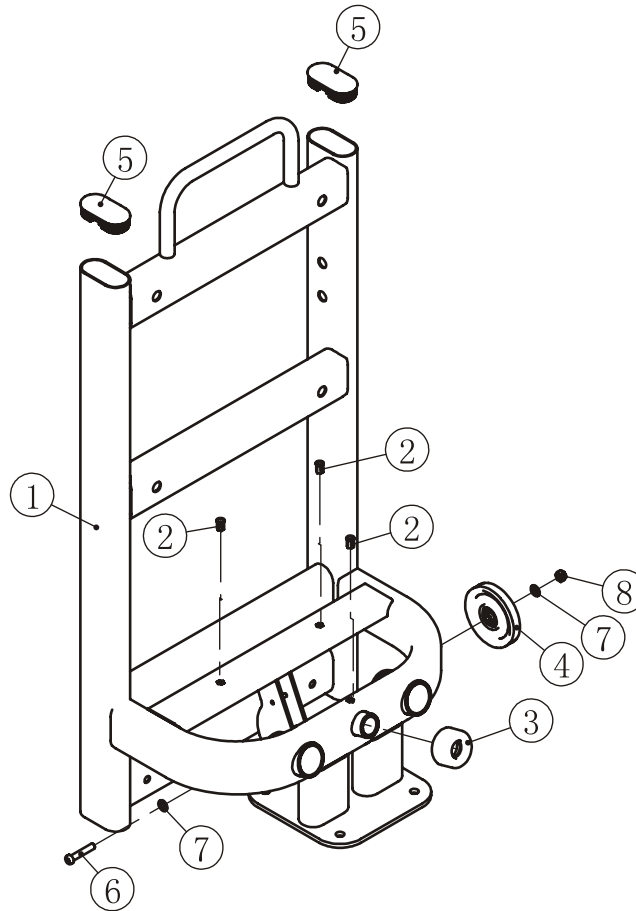

ItemNo.	Grade No.	Part No.	Description	QTY
1	4.1	IT95100400	Front Frame	1
2	4.2	GB17880.5M8*16.5DCS17	Rivet Nut M8	3
3	4.3	IT95102100	Urethane Bumper	1
4	4.4	SG500110400V5	4.5" Pulley	1
5	4.5	IT90013800P11C	Plug RT50*100	2
6	4.6	GB70BTM10*55DN18	Socket Head Cap Screw M10*55	1
7	4.7	GB9510DN2	Flat Washer $\phi 11 * \phi 20 * 2$	2
8	4.8	NM10DN2	Nylon Lock Nut M10	1

Exploded View and Parts List

Seat Carriage Frame ASSY

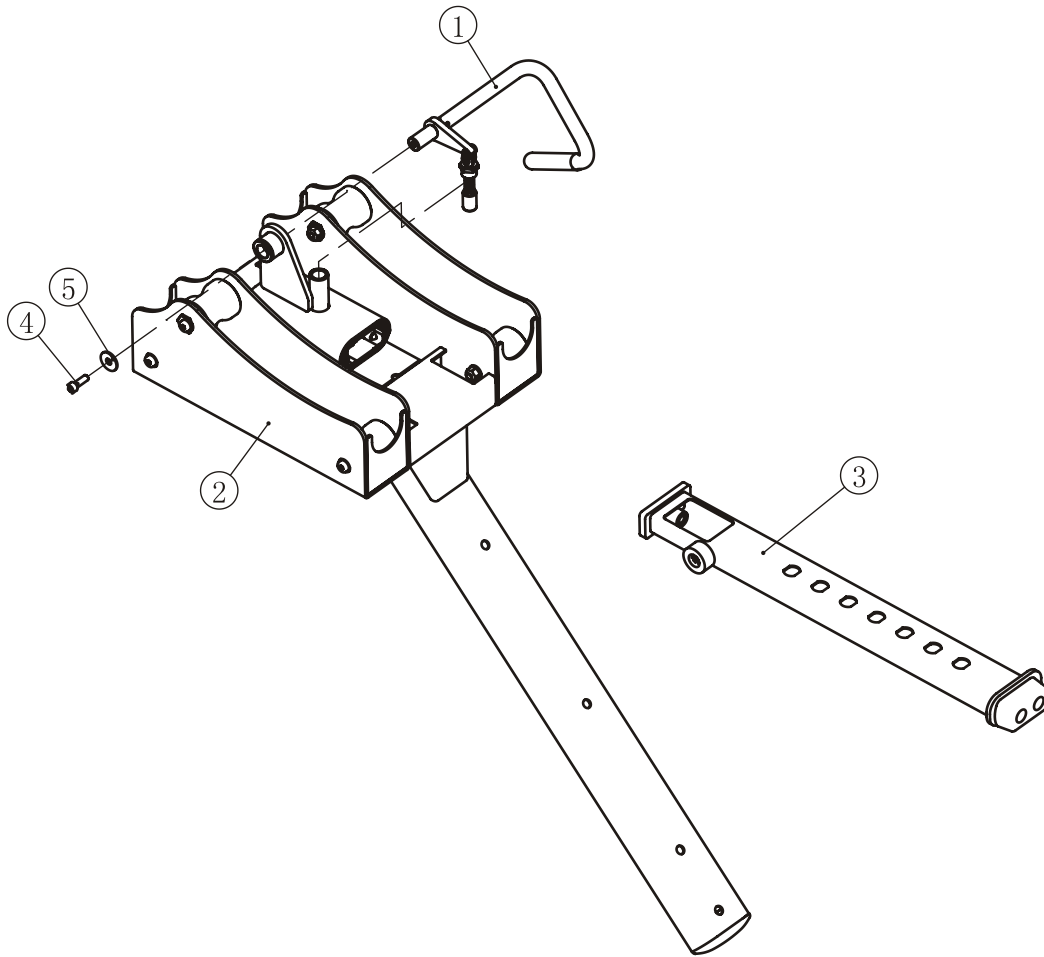

ItemNo.	Grade No.	Part No.	Description	QTY
1	6.1	IT951007ASSY	Adjustable Handle Frame ASSY	1
2	6.2	IT951008ASSY	Seat Frame ASSY	1
3	6.3	IT951009ASSY	Sliding Frame ASSY	1
4	6.4	GB70M8*25N19	Socket Head Cap Screw M8*25	1
5	6.5	DQ8DS2B	Flat Washer ϕ 9* ϕ 16*1.6	1

Exploded View and Parts List

Adjustable Handle Frame ASSY

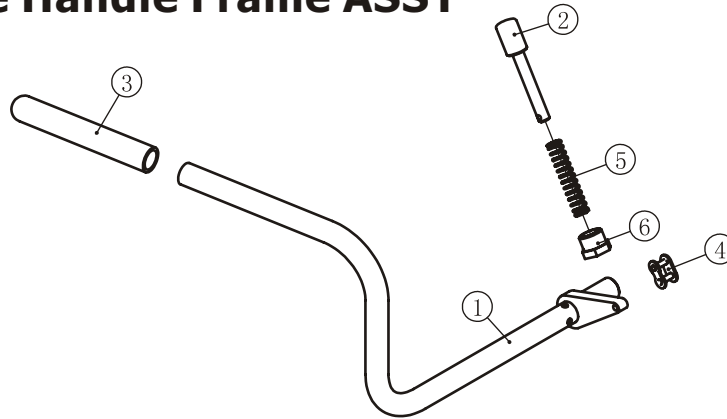

ItemNo.	Grade No.	Part No.	Description	QTY
1	6.1.1	IT95100700	Adjustable Handle Frame	1
2	6.1.2	IT95101100	Pin	1
3	6.1.3	FS522800	Grip	1
4	6.1.4	GB/T1243-199708BN19	Chain	1
5	6.1.5	SG80071200B	Spring	1
6	6.1.6	KPS18002701V1	Nut M20*1.5*18	1

Sliding Frame ASSY

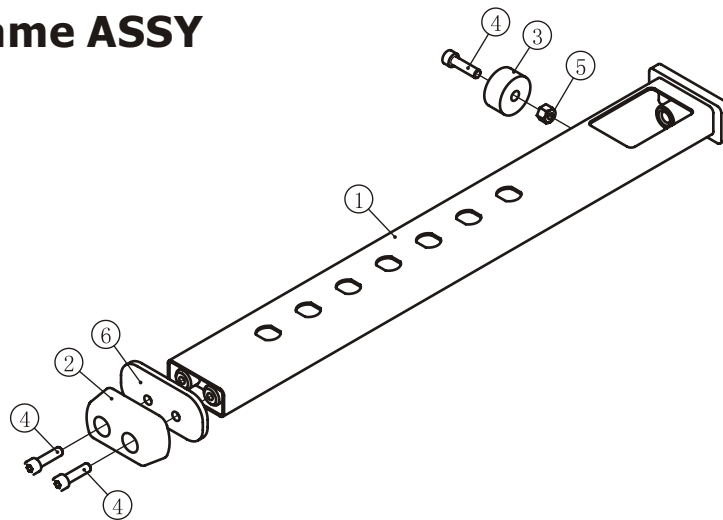

Item No.	Grade No.	Part No.	Description	QTY
1	6.3.1	IT95100900	Sliding Frame	1
2	6.3.2	RS17000400	Bumper	1
3	6.3.3	BNH0514	Bumper	1
4	6.3.4	GB70M8*30N19	Socket Head Cap Screw M8*30	3
5	6.3.5	NMM8DN2	Nylon Lock Nut M8	1
6	6.3.6	IT95101300	Securing plate	1

Exploded View and Parts List

Seat Frame ASSY

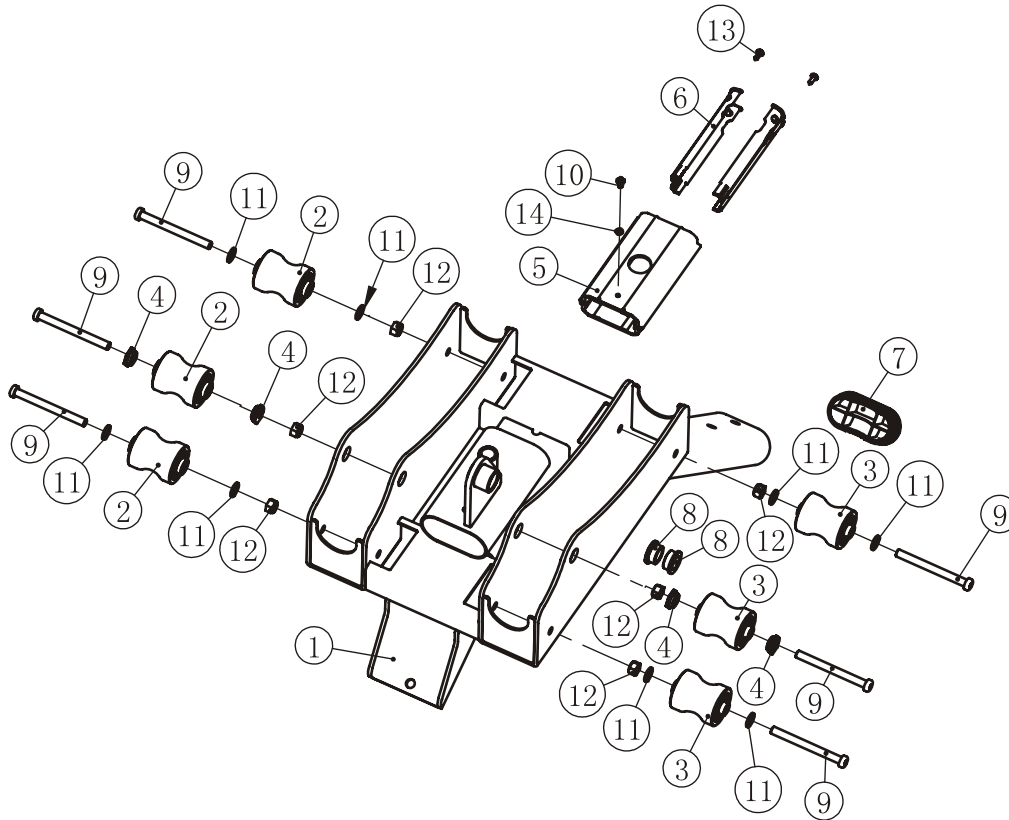

ItemNo.	Grade No.	Part No.	Description	QTY
1	6.2.1	IT95100800	Seat Frame	1
2	6.2.2	IT951010ASSY	Roller Group1	3
3	6.2.3	IT951011ASSY	Roller Group2	3
4	6.2.4	IT95101200	Eccentric Washer	4
5	6.2.5	IT95102300	Aluminum Tube Guide	1
6	6.2.6	IT95016300	Plastic Corner Tube Glide	4
7	6.2.7	IT90013800P11C	Plug RT50*100	1
8	6.2.8	HVCORE5300	Bushing Φ 19	2
9	6.2.9	GB70BTM10*105DN18	Socket Head Cap Screw M10*105	6
10	6.2.10	GB70M6*10N19	Socket Head Cap Screw M6*10	1
11	6.2.11	GB9510DN2	Flat Washer Φ 11* Φ 20*2	8
12	6.2.12	NM10DN2	Nylon Lock Nut M10	6
13	6.2.13	GB845ST4.8*13DS2	Cross Recessed Pan Head Self-drilling Tapping Screw ST4.8*13	2
14	6.2.14	GB936N19	SPLIT LOCK WASHER Φ 6	1

Exploded View and Parts List

Roller Group 1

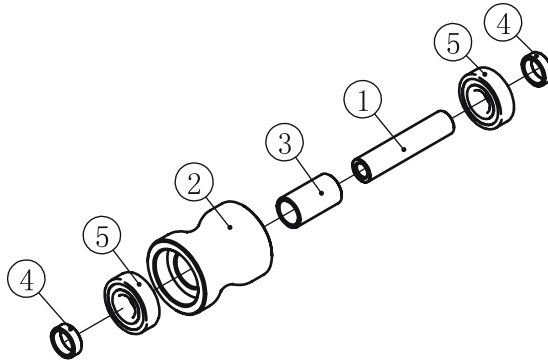

ItemNo.	Grade No.	Part No.	Description	QTY
1	6.2.2.1	IT95102200	Pin	1
2	6.2.2.2	BNH2472-01V1	Roller	1
3	6.2.2.3	BNH2472-03	Roller Spacer	1
4	6.2.2.4	FE97122100	Pulley Spacer1	2
5	6.2.2.5	GB2766203-2Z	Deep Groove Ball Bearing $\phi 17^* \phi 40^*12$	2

Roller Group 2

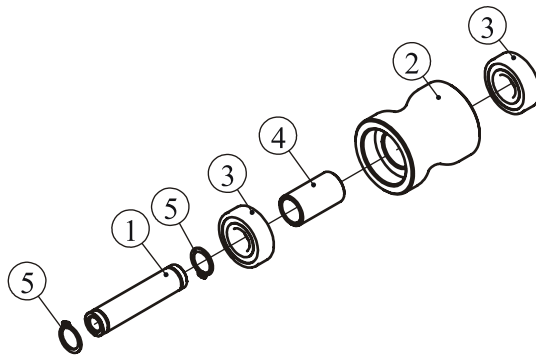

ItemNo.	Grade No.	Part No.	Description	QTY
1	6.2.3.1	IT95102200	Pin	1
2	6.2.3.2	BNH2472-01V1	Roller	1
3	6.2.3.3	GB2766203-2Z	Deep Groove Ball Bearing $\phi 17^* \phi 40^*12$	2
4	6.2.3.4	BNH2472-03	Roller Spacer	1
5	6.2.3.5	GB894.117FH12	Circlip For Shaft	2

Exploded View and Parts List

Assist Grip Frame ASSY

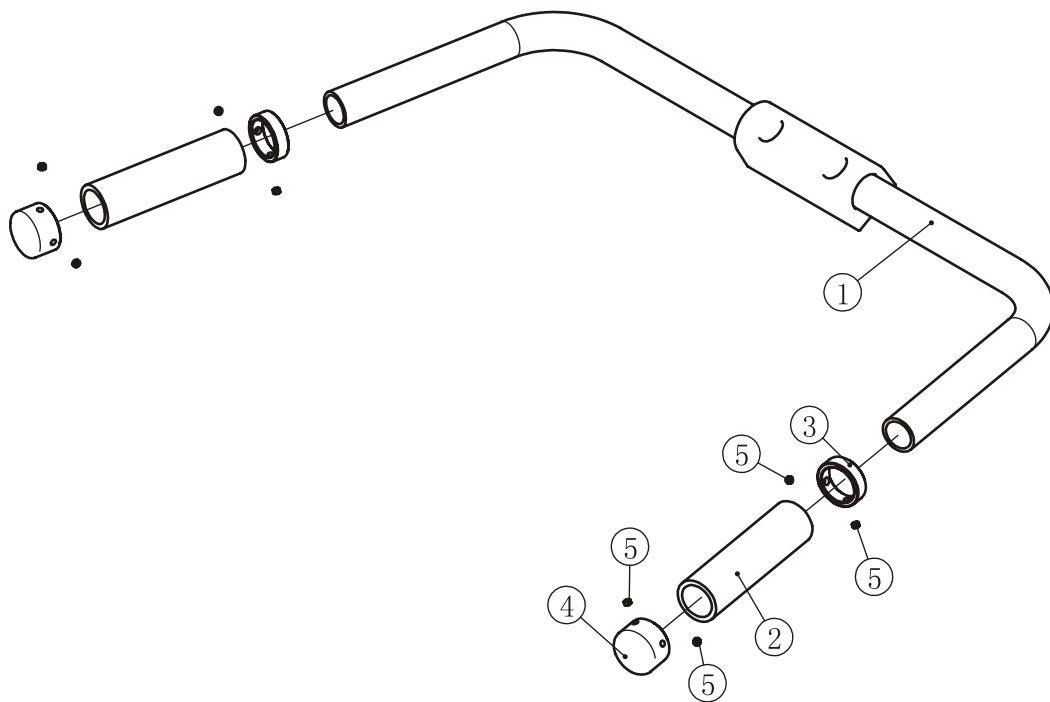

ItemNo.	Grade No.	Part No.	Description	QTY
1	7.1	IT95100600	Assist Grip Frame	1
2	7.2	026-01PL0206-5	Grip	2
3	7.3	V39500	Aluminum Grip Cap	2
4	7.4	V39600	Aluminum Grip Ring	2
5	7.5	YZGB7710-32*3.2N19	Socket Set Screw 10-32UNF*3.2	8

Exploded View and Parts List

Front Pedal ASSY

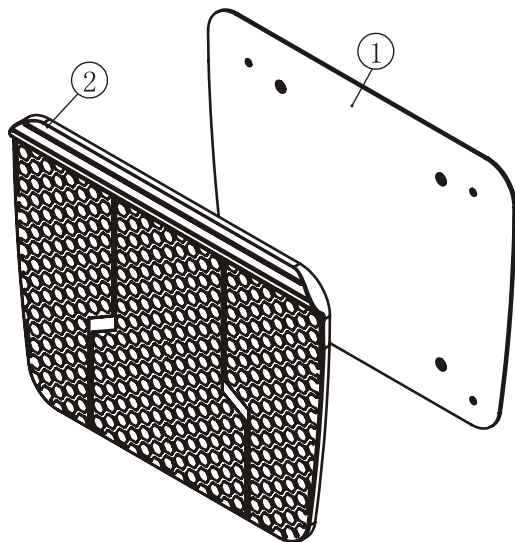

Cable1 ASSY

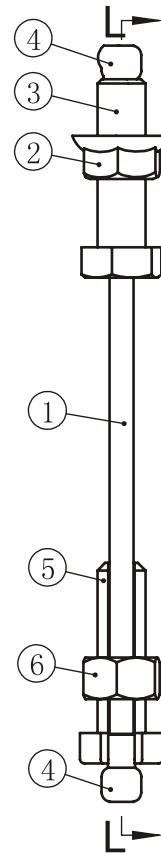

Front Pedal ASSY

ItemNo.	Grade No.	Part No.	Description	QTY
1	8.1	IT95101500	Front Pedal Frame	1
2	8.2	FE97102000	Pedal Plate	1

Cable1 ASSY

ItemNo.	Grade No.	Part No.	Description	QTY
1	11.1	IT95101801	Cable1	1
2	11.2	HF900-03A1002	Hex Flange Nut	2
3	11.3	HS11757602	Screw 1/2"-13*50.8	1
4	11.4	HS11757603	Terminal Block	2
5	11.5	IT95101400	Screw 1/2"-13*45	1
6	11.6	YLM0.5*13*11DS2	Hex Nut 1/2"-13	1

Exploded View and Parts List

Back Pad ASSY

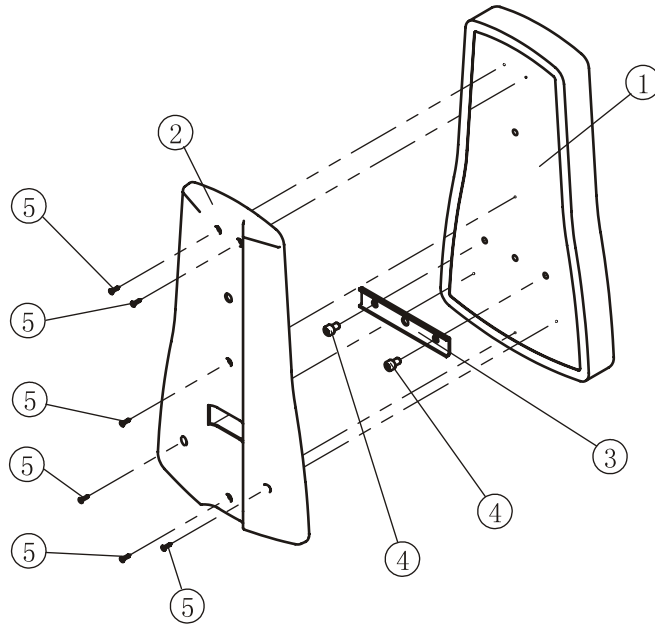

ItemNo.	Grade No.	Part No.	Description	QTY
1	16.1	IT95017100	Back Pad	1
2	16.2	IT95017300	Back Pad Cover	1
3	16.3	IT95017500	Back Pad Support Plate	1
4	16.4	GB70M10*15DS20	Socket Head Cap Screw M10*15	2
5	16.5	GB846ST4.2*19DHS	Cross Recessed Countersunk Head Tapping Screw ST4.2*19	6

Head Pad ASSY

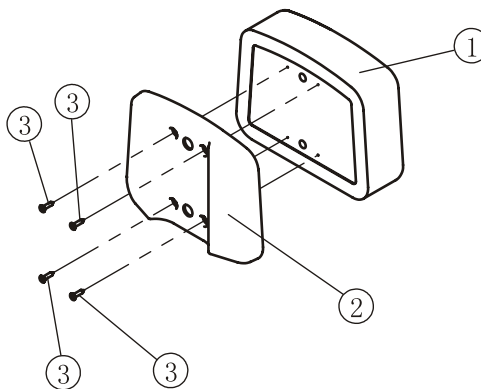

ItemNo.	Grade No.	Part No.	Description	QTY
1	15.1	IT95017200	Head Pad	1
2	15.2	IT95017400	Head Pad Cover	1
3	15.3	GB846ST4.2*19DHS	Cross Recessed Countersunk Head Tapping Screw ST4.2*19	4

Measurement Guide

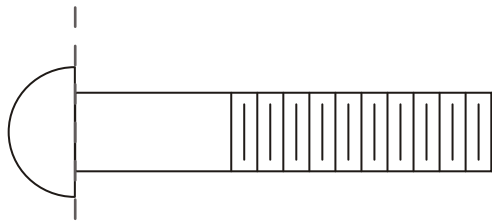

BHCS = Button Head Cap Screw

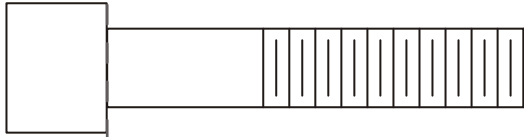

SHCS = Socket Head Cap Screw

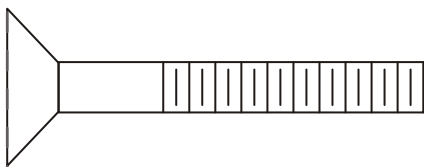

FHCS = Flat Head Cap Screw

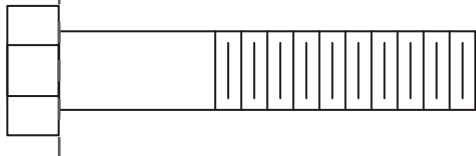

HHB = Hex Head Bolt

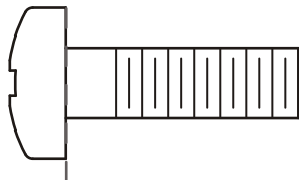

CRPHS = Cross Recessed Pan Head Screw

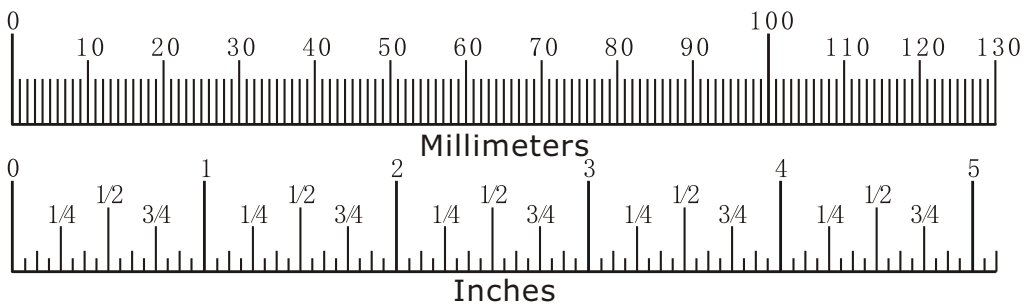

Diameter of bolt (mm/inch)	M6(1/4")	M8(5/16")	M10(3/8")	M12(1/2")	M16(5/8")
Tightening torque (N.m)	9~12	22~30	45~59	78~104	193~257
Operational methods for adult men	The strength of the wrist	The strength of the wrist and forearm	The strength of the entire arm	The strength of the arm and upper body	with all strength

Assembly Instructions

Assembly of the equipment takes professional installers about 2 hours. If this is the first time you have assembled this type of equipment, plan to spend more time. It is strongly recommended to assemble the equipment by professional installers. You may find it quicker, safer, easier to assemble this equipment with the help of a friend, as some of components may be large, heavy or awkward to handle alone. It is important that you assemble your product in a clean, clear, uncluttered area. This will enable you to move around the product while you are fitting components and reduce the possibility of injury during assembly.

NOTE

As with any assembled part, proper alignment and adjustment is critical. While tightening the fasteners, be sure to leave room for adjustments. Do not fully tighten the fasteners until instructed to do so. Be careful to assemble the components in the sequence presented in this guide.

Assembly

STEP 1

1. Attach four Adjustable Foot Plates (#19) to the Main Frame ASSY (#2) and Front Frame ASSY (#4).
2. Attach the Rear Bracket (#23) to the Top Rear Shroud (#28) using:
two M6*10 CRPHS (#50)
3. Attach the Main Frame ASSY (#2) to the Front Frame ASSY (#4) using:
four M12*80 SHCS (#39) two M12 Nylon Lock Nut (#54)
four M12*30 SHCS (#41) six $\Phi 13*\Phi 24*2.5$ Flat Washer (#51)
four Support Sleeve (#37)

Note: Wrench Tighten Bolts and Nylon Lock Nuts.

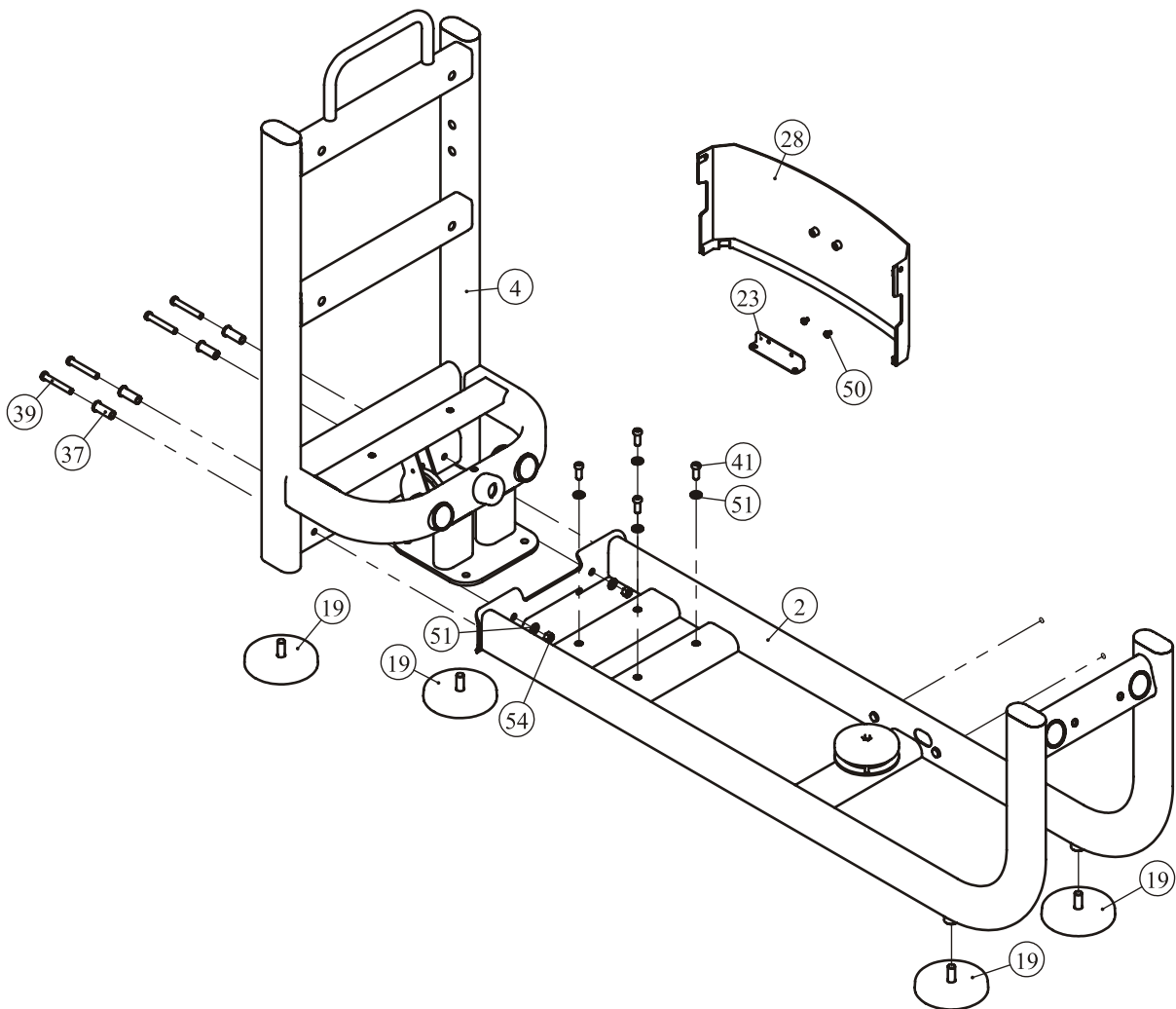

Assembly

STEP 2

Attach Bottom Frame Brace (#3), Front Connection Frame (#5) to the Main Frame ASSY (#2), Front Frame ASSY (#4), Weight Stack Frame ASSY (#1) using:

two M12*90 SHCS (#38)

four M12*30 SHCS (#41)

four M10*80 SHCS (#42)

two Support Sleeve (#37)

two M10 Nylon Lock Nut (#55)

four $\Phi 13 \times \Phi 24 \times 2.5$ Flat Washer (#51)

four $\Phi 11 \times \Phi 20 \times 2$ Flat Washer (#52)

one Ellipse Plate (#17)

Note: Wrench Tighten Bolts and Nylon Lock Nuts.

Adjust the Adjustable Foot Plates to make the machines stable.

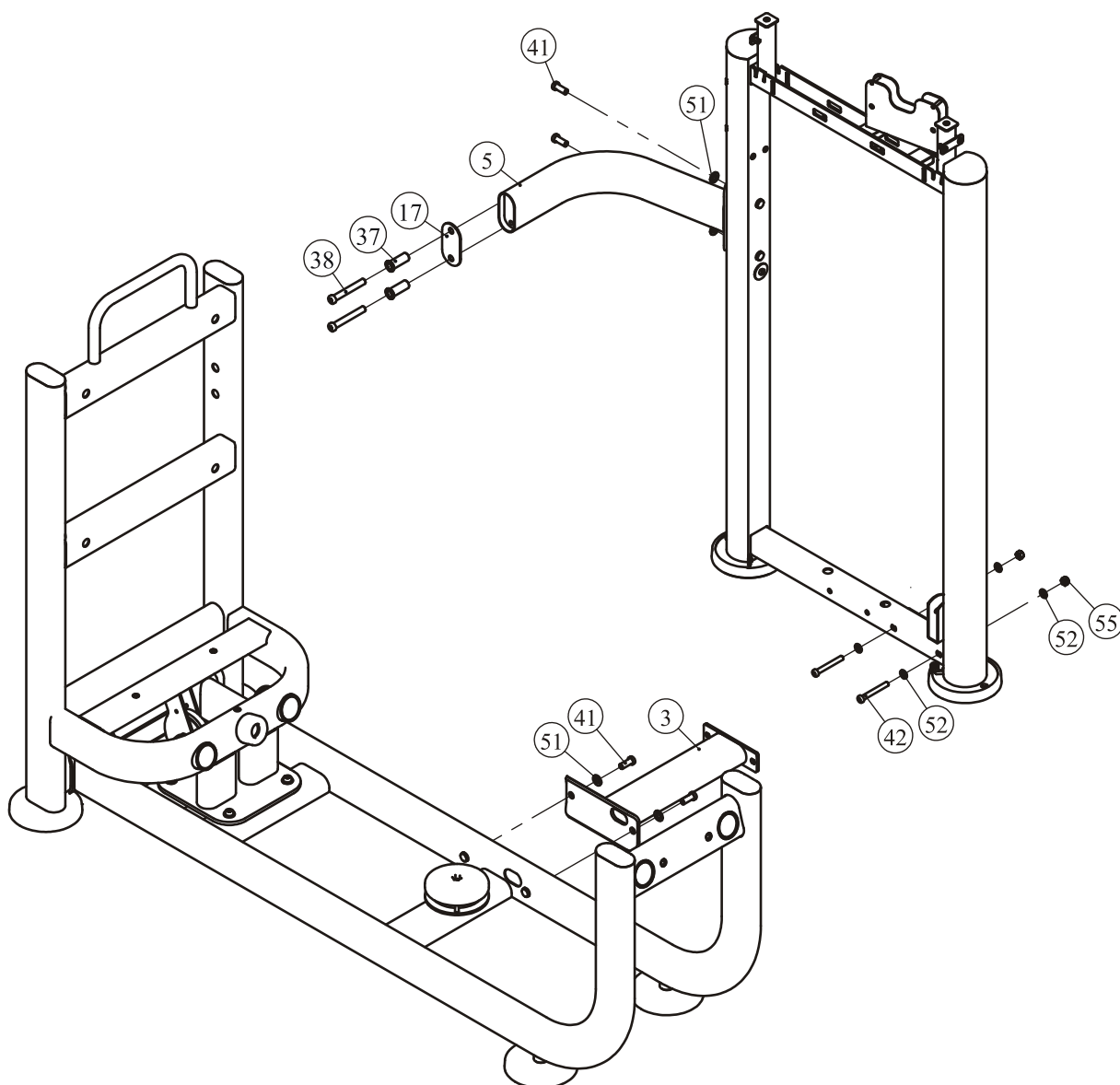

Assembly

STEP 3

1. Attach one 4.5" Pulleys (#18) to the Weight Stack Frame ASSY (#1) using:
one M10*50 SHCS (#44) two $\Phi 11*\Phi 20*2$ Flat Washer (#52)
one M10 Nylon Lock Nut (#55)
2. Attach the Top Bracket ASSY (#21) and two Bottom Bracket ASSY (#22) to the Weight Stack Frame ASSY (#1) using:
two M8*20 SHCS (#47) two $\Phi 9*\Phi 16*1.6$ Flat Washer (#53)
two M10*75 SHCS (#43) four $\Phi 11*\Phi 20*2$ Flat Washer (#52)
two M10 Nylon Lock Nut (#55)
3. Attach Assist Grip Frame ASSY (#7) to Seat Carriage Frame ASSY (#6) using:
two M10*45 SHCS (#40) two Washer $\Phi 10$ (#74)
4. Take the two Sliding Guide Rods (#9) Through the rear hole of the Main Frame ASSY (#2), Through the rollers of Seat Carriage Frame ASSY (#6), two Big Spring s four Nylon Baffle Ring into the hole on the Front Frame ASSY (#4), Attach the Connecting Plate on, using:
four M12*30 SHCS (#41) four $\Phi 13*\Phi 24*2.5$ Flat Washer (#51)
four M8*30 SHCS (#46) four $\Phi 9*\Phi 16*1.6$ Flat Washer (#53)

Note: Wrench Tighten Bolts and Nylon Lock Nuts.

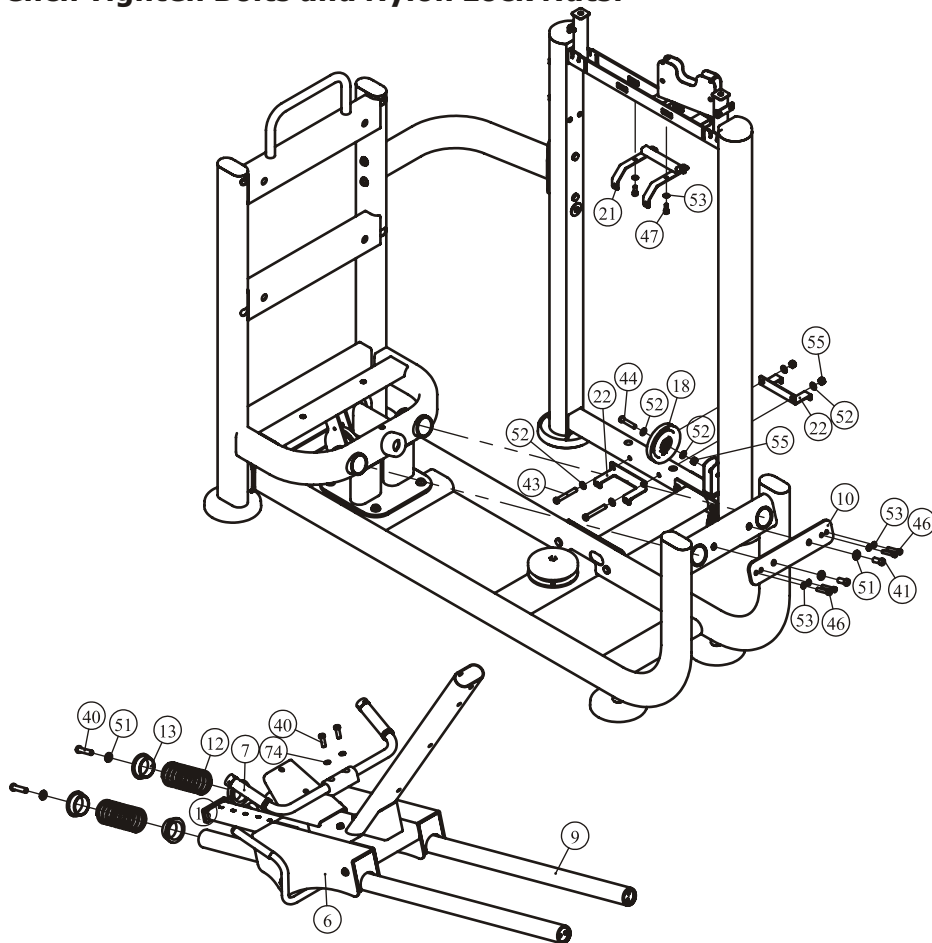

Assembly

STEP 4

Here is the assembly instruction for **160LBS Weights !**

1. Attach:

two Guide Rod $\Phi 19 \times 1242$ (#25)
 fifteen Weight Plate 10LBS (#63)
 one Top Plate (#24)

two Weight Rubber Bumper (#32)
 two weight stack space (#64)

to the Weight Stack Frame ASSY (#1) using:

two Guide Rod Fixing Sleeve $\Phi 25 \times \Phi 19 \times 45$ (#34)
 two Spring (#35)

2. Attach the Selector Pin W/Coil (#33) to the Top Plate (#24).

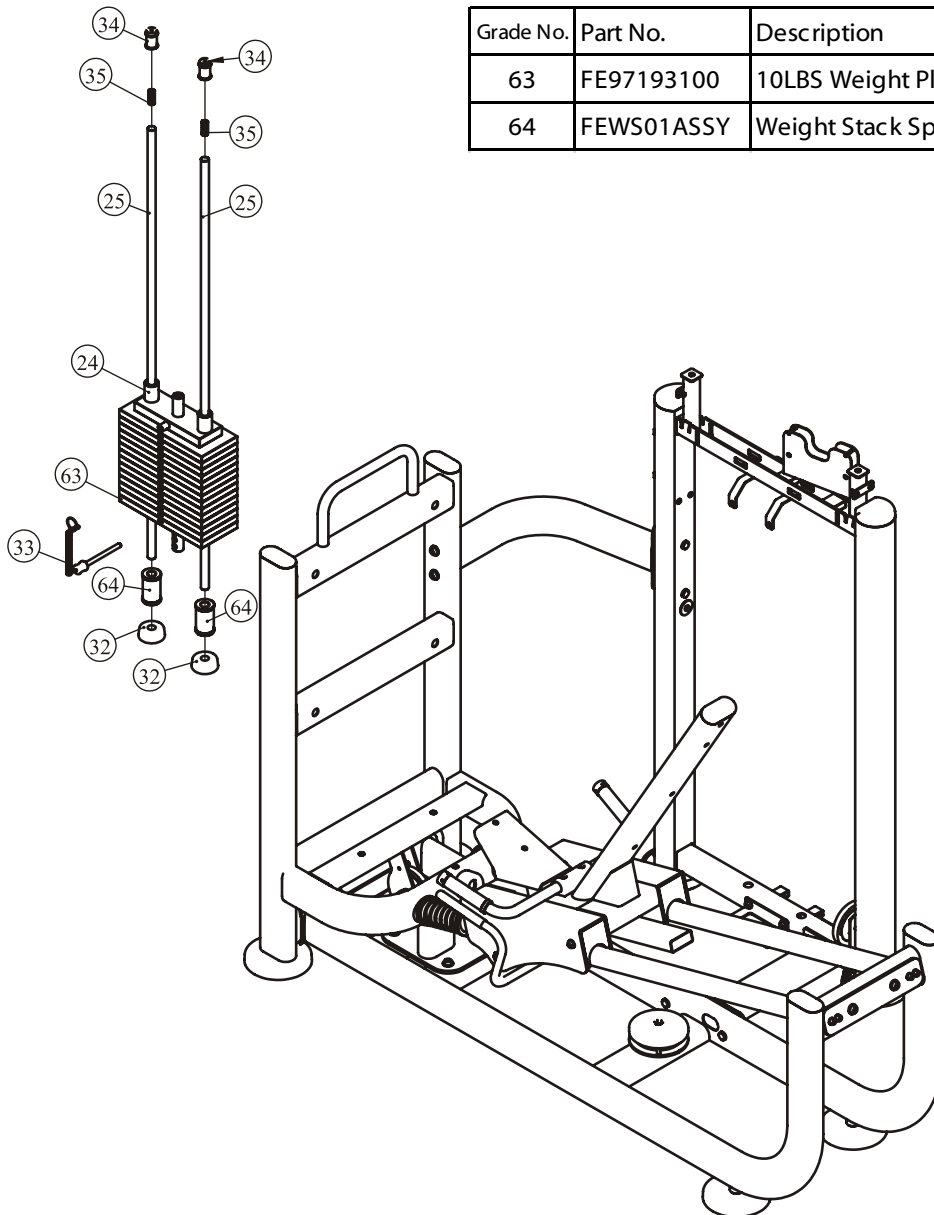

Grade No.	Part No.	Description	QTY
63	FE97193100	10LBS Weight Plate	15
64	FEWS01ASSY	Weight Stack Space	2

Assembly

STEP 4

Here is the assembly instruction for **200LBS Weights !**

1. Attach:

two Guide Rod $\Phi 19 \times 1242$ (#25) two Weight Rubber Bumper (#32)
 nineteen Weight Plate 10LBS (#63) one Top Plate (#24)

to the Weight Stack Frame ASSY (#1) using:

two Guide Rod Fixing Sleeve $\Phi 25 \times \Phi 19 \times 45$ (#34)
 two Spring (#35)

2. Attach the Selector Pin W/Coil (#33) to the Top Plate (#24).

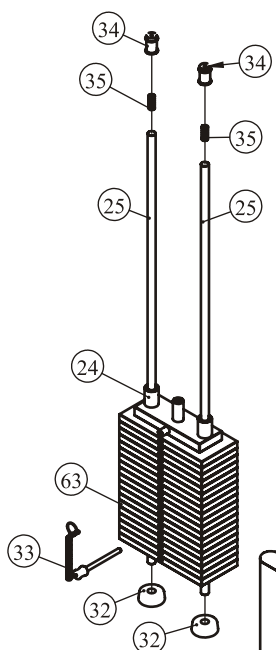

Grade No.	Part No.	Description	QTY
63	FE97193100	10LBS Weight Plate	19

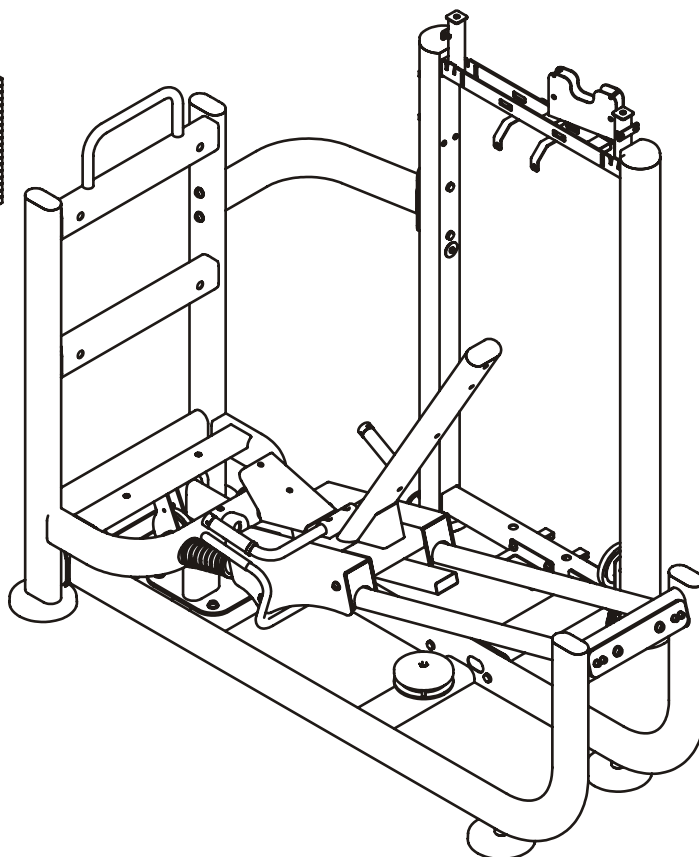

Assembly

STEP 4

Here is the assembly instruction for **235LBS Weights !**

1. Attach:

two Guide Rod $\Phi 19 \times 1242$ (#25)
 fifteen Weight Plate 15LBS (#65)
 one Top Plate (#24)

two Weight Rubber Bumper (#32)
 two weight stack space (#64)

to the Weight Stack Frame ASSY (#1) using:

two Guide Rod Fixing Sleeve $\Phi 25 \times \Phi 19 \times 45$ (#34)
 two Spring (#35)

2. Attach the Selector Pin W/Coil (#33) to the Top Plate (#24).

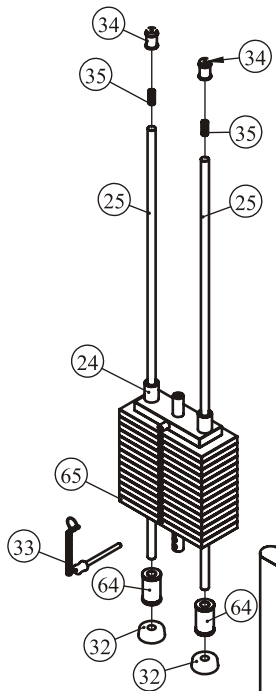

Grade No.	Part No.	Description	QTY
65	FE97193200	15LBS Weight Plate	15
64	FEWS01ASSY	Weight Stack Space	2

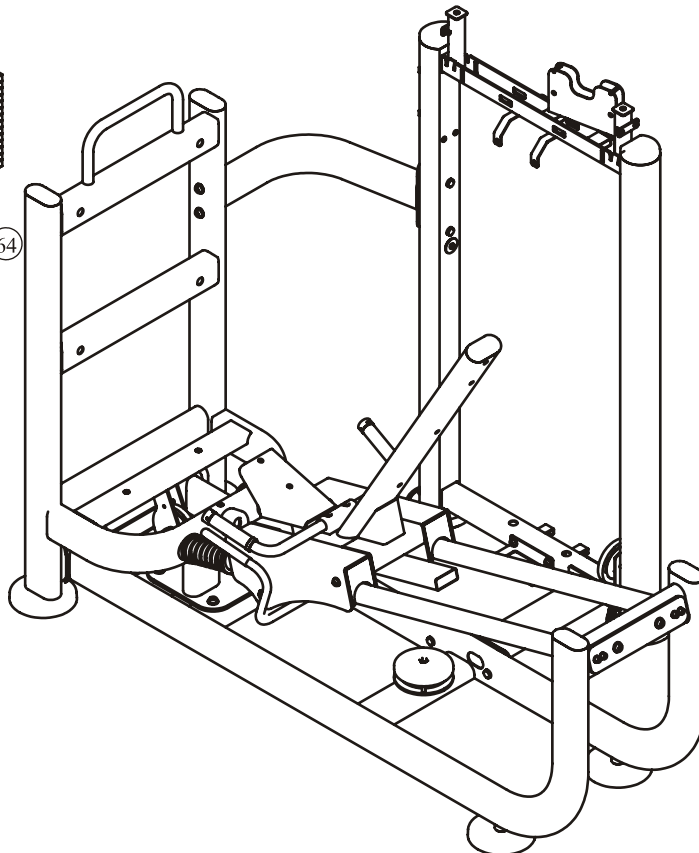

Assembly

STEP 4

Here is the assembly instruction for **295LBS Weights !**

1. Attach:

two Guide Rod $\Phi 19 \times 1242$ (#25) two Weight Rubber Bumper (#32)
nineteen Weight Plate 15LBS (#65) one Top Plate (#24)

to the Weight Stack Frame ASSY (#1) using:

two Guide Rod Fixing Sleeve $\Phi 25 \times \Phi 19 \times 45$ (#34)

two Spring (#35)

2. Attach the Selector Pin W/Coil (#33) to the Top Plate (#24).

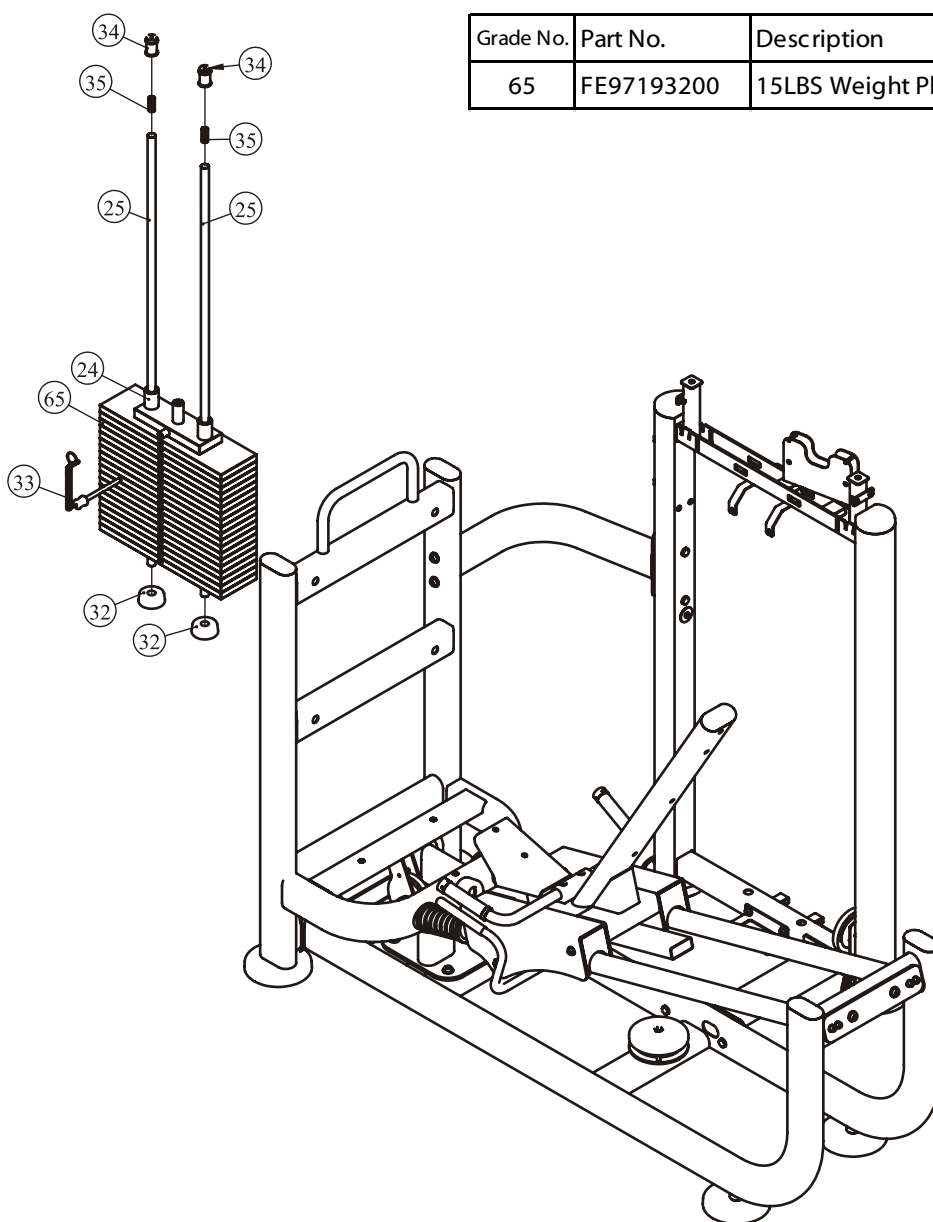

Assembly

All weight plate sticker paste schematic diagram

LBS 20	9
LBS 30	14
LBS 40	18
LBS 50	23
LBS 60	27
LBS 70	32
LBS 80	36
LBS 90	41
LBS 100	45
LBS 110	50
LBS 120	54
LBS 130	59
LBS 140	64
LBS 150	68
LBS 160	73
LBS 170	77
LBS 180	82
LBS 190	86
LBS 200	91
LBS 210	95
LBS 220	100
LBS 230	104

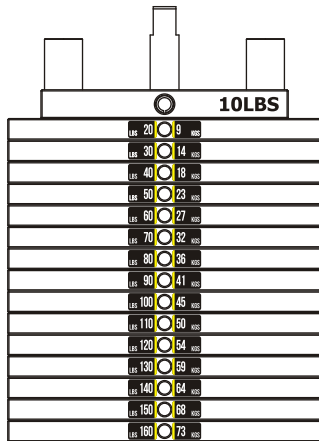

20-160LBS

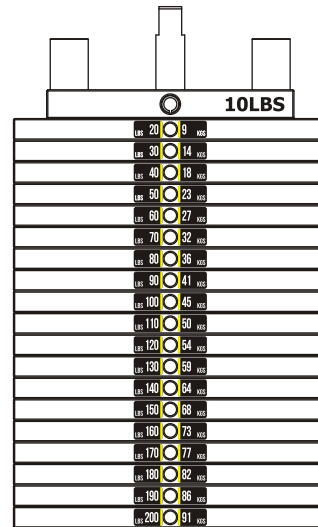

20-200LBS

LBS 25	11
LBS 40	18
LBS 55	25
LBS 70	32
LBS 85	38
LBS 100	45
LBS 115	52
LBS 130	59
LBS 145	66
LBS 160	72
LBS 175	79
LBS 190	86
LBS 205	93
LBS 220	100
LBS 235	107
LBS 250	113
LBS 265	120
LBS 280	127
LBS 295	134
LBS 310	141
LBS 325	147

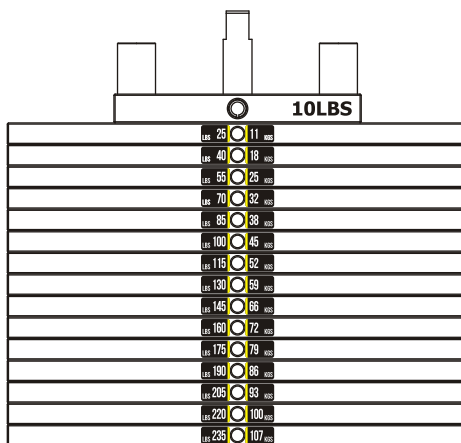

25-235LBS

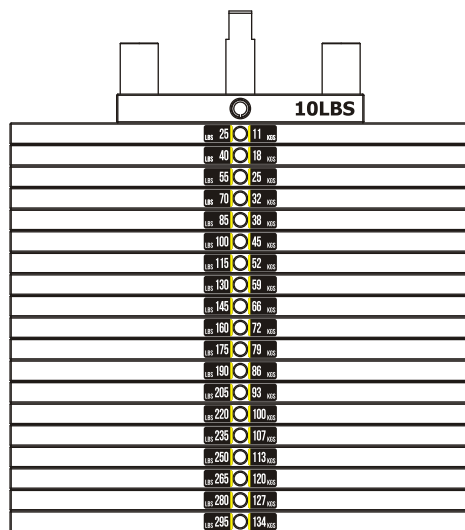

25-295LBS

Assembly

STEP 5

1. Attach two 4.5" Pulleys (#18) to the Weight Stack Frame ASSY (#1) using:
 - two M10*50 SHCS (#44)
 - four $\Phi 11*\Phi 20*2$ Flat Washer (#52)
 - two M10 Nylon Lock Nut (#55)
2. Attach the two ends of the Cable ASSY (#11) to the Top Plate (#24) and the Seat Carriage Frame ASSY (#6).

Note: Wrench tighten bolts and Nylon Lock Nuts.

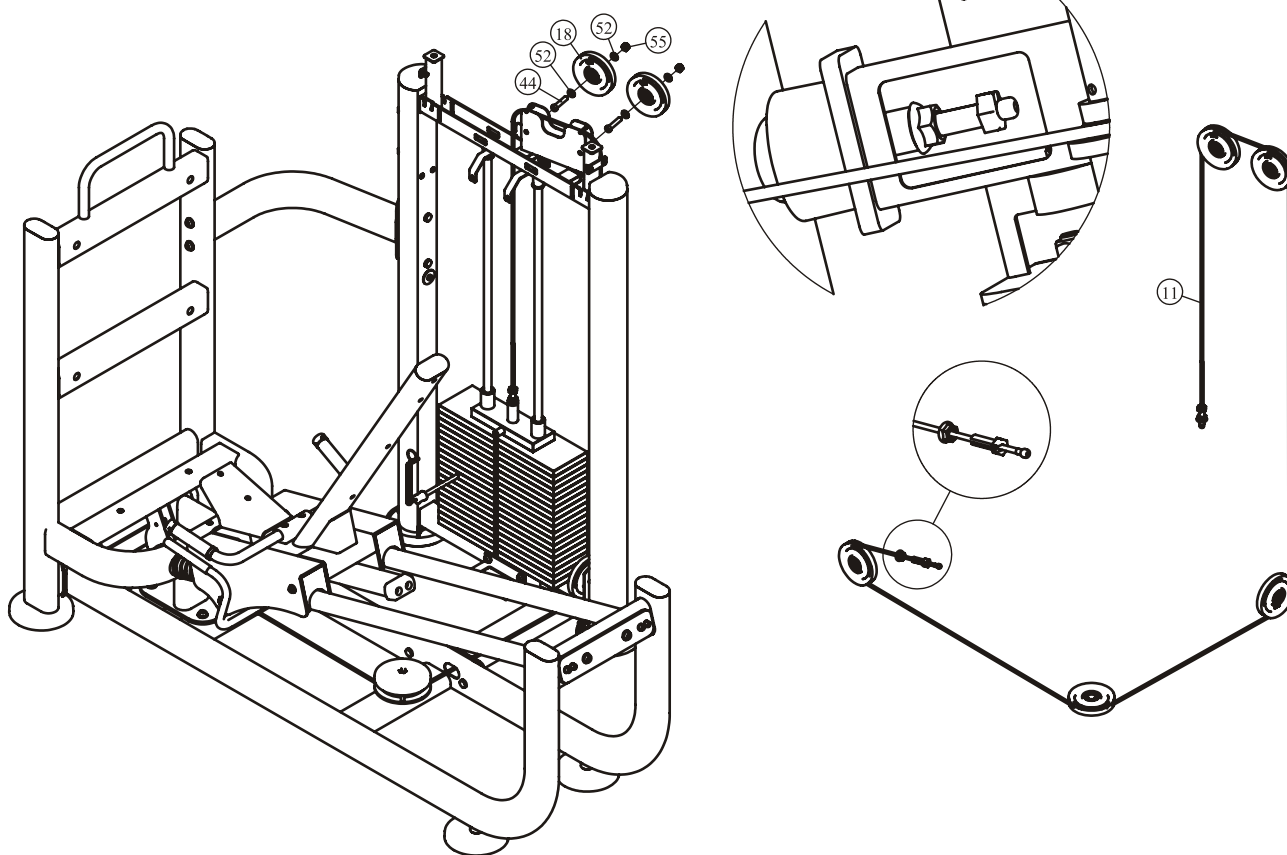

Assembly

STEP 6

Tips: Pre-assemble the 8 bolt into the Weight Stack Frame ASSY and Bottom Bracket ASSY, not wrench tighten Bolts, Assemble the shroud with the bolt on. Then wrench tighten Bolts.

1. Attach the Right Front Shroud (#30) and the Front Shroud (#29) to the Weight Stack Frame ASSY (#1) and the Bottom Bracket ASSY (#22) using:
 - four M6*20 CRPHS (#48)
 - two M6*16 CRPHS (#49)
2. Attach the Rear Shroud (#31) to the Weight Stack Frame ASSY (#1) and the Bottom Bracket ASSY (#22) using:
 - four M6*20 CRPHS (#48)
 - two M6*16 CRPHS (#49)
3. Attach the Training Placard Cover (#27) to the Weight Stack Frame ASSY (#1) and the Top Bracket ASSY (#21) using:
 - two M6*20 CRPHS (#48)
 - two M6*10 CRPHS (#50)
4. Attach the Top Rear Shroud (#28) to the Weight Stack Frame ASSY (#1) and the Top Bracket ASSY (#21) using:
 - four M6*20 CRPHS (#48)
5. Attach the Top Cover (#26) to the Weight Stack Frame ASSY (#1) using:
 - two M6*20 CRPHS (#48)
 - two Spout Plug $\Phi 16.5 \times 6.88$ (#36)
6. Attach the Cup Holder (#20) to the Weight Stack Frame ASSY (#1) using:
 - two M6*20 CRPHS (#48)

Note: Wrench tighten bolts.

Assembly

STEP 6

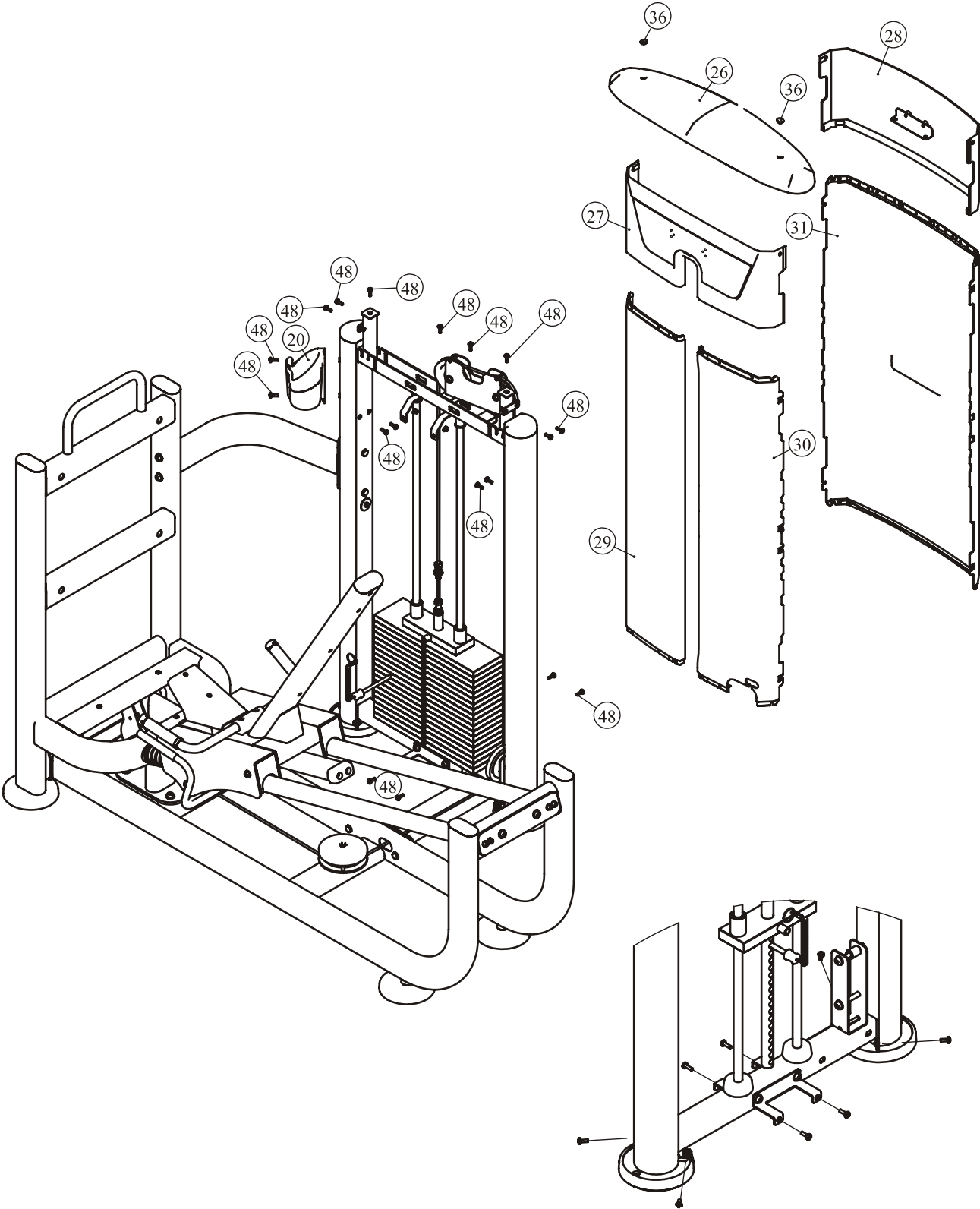

Assembly

STEP 7

Attach the Seat Pad (#14), Head Pad ASSY (#15), Back Pad ASSY (#16) to the Seat Carriage Frame ASSY (#6), Attach the Auxiliary Pedal (#71) to Front Frame ASSY (#4) using:

- four M10*80 SHCS (#42)
- ten $\Phi 11*\Phi 20*2$ Flat Washer (#52)
- six M10*30 SHCS (#45)
- three M8*20 FHCS (#72)

Note: Wrench tighten bolts and Nylon Lock Nuts.

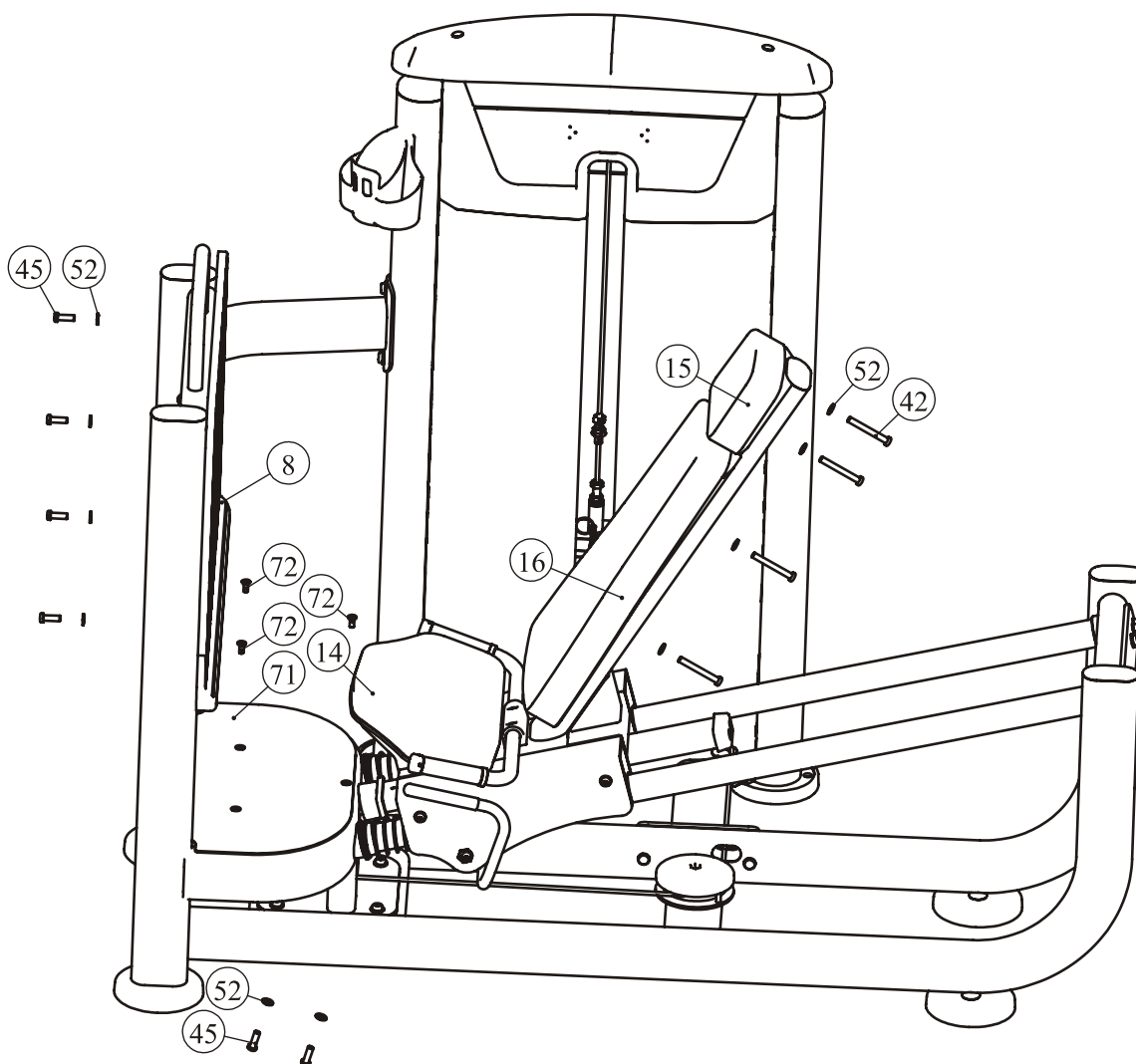

Adjust Instructions

The seat Pad adjustment

1. Push the Adjustable Support and adjust the Chest Pad to the desired position.
2. Make sure the pin gets into the hole completely.

The use of Selector Pin W/Coil

1. Select an appropriate weight and put the Selector Pin W/Coil into the hole on it.
2. Make sure the Selector Pin W/Coil gets into the hole completely.

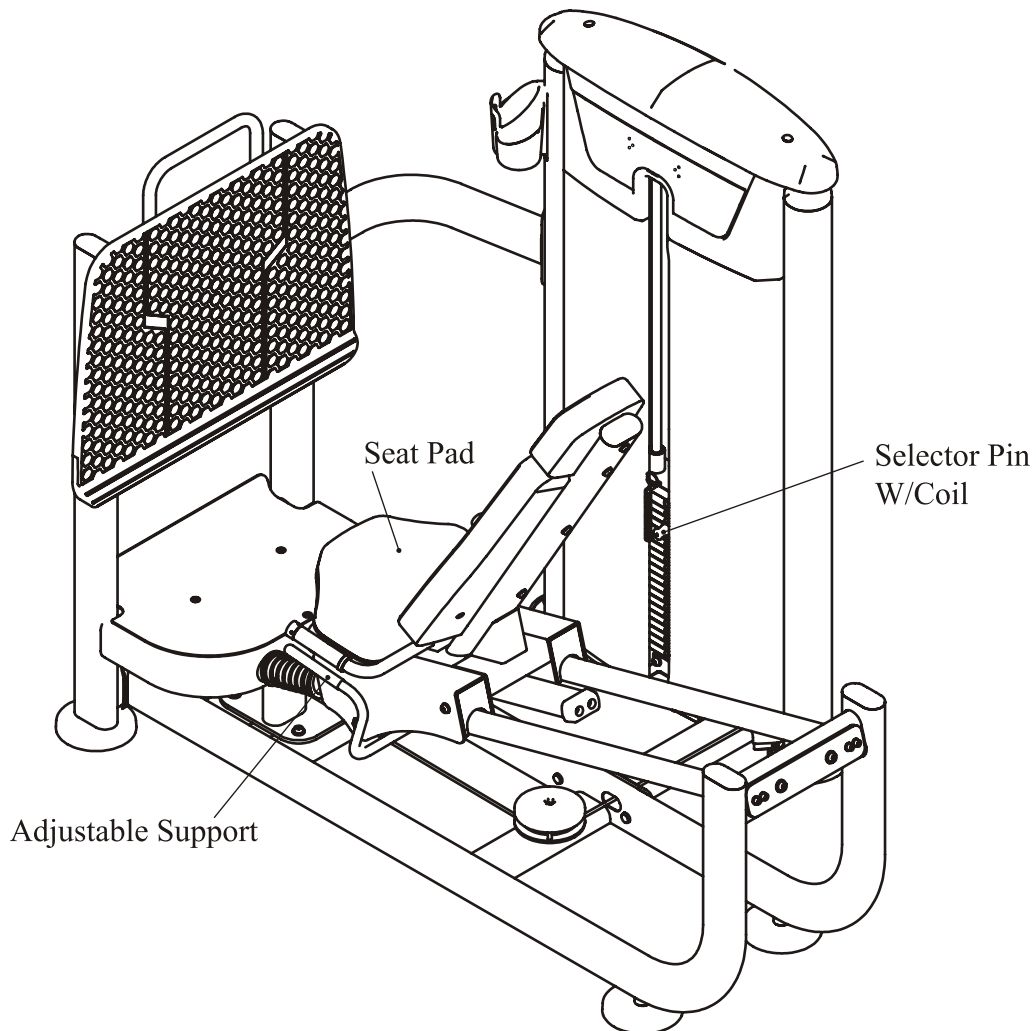

Exercise Instructions

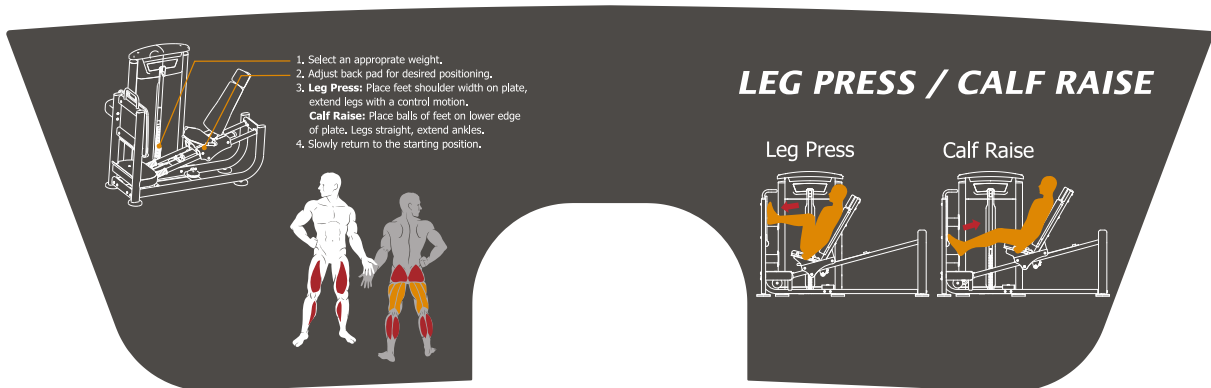

1. Select an appropriate weight.
 2. Adjust back pad for desired positioning.
 3. **Leg Press:** Place feet shoulder width on plate, extend legs with a control motion.
Calf Raise: Place balls of feet on lower edge of plate. Legs straight, extend ankles.
 4. Slowly return to the starting position.

LEG PRESS / CALF RAISE

Leg Press Calf Raise

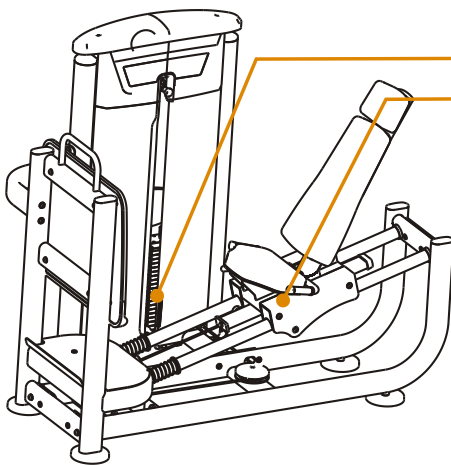

1. Select an appropriate weight.
2. Adjust back pad for desired positioning.
3. **Leg Press:** Place feet shoulder width on plate, extend legs with a control motion.
Calf Raise: Place balls of feet on lower edge of plate. Legs straight, extend ankles.
4. Slowly return to the starting position.

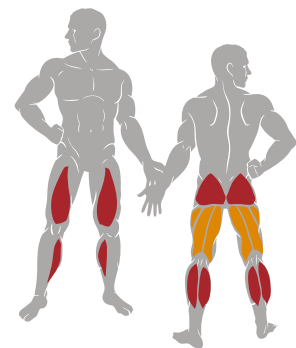

Leg Press

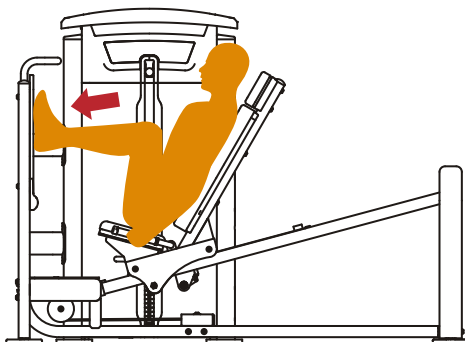

Calf Raise

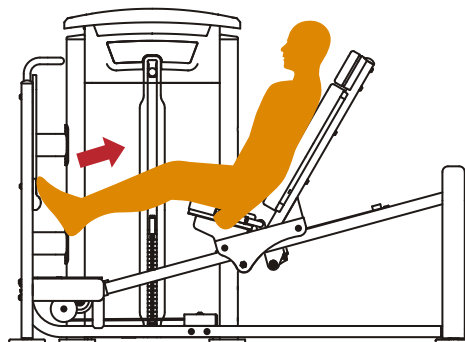

Maintenance Schedule

ROUTINE	COMMERCIAL MAINTENANCE	HOME MAINTENANCE	LATEST DATE ENTRY					
Inspect; Links, Pull Pins, Snap Locks, Swivels, Weight Stack Pins	DAILY	WEEKLY						
Clean; Upholstery	DAILY	WEEKLY						
Inspect; Cables or Belts and their tension	DAILY	WEEKLY						
Inspect; Accessory Bars, and Handles	WEEKLY	3 MONTHS						
Inspect; All Decals	WEEKLY	3 MONTHS						
Inspect; All Nuts and Bolts, Tighten if needed	WEEKLY	3 MONTHS						
Inspect; Anti-Skid Surface	WEEKLY	3 MONTHS						
Clean & Lubricate; Guide Rods with a Teflon (PTFE) based lubricant (Superlube)	MONTHLY	3 MONTHS						
Lubricate; Seat Sleeves, Turcite Bushings, Linear Bearing	MONTHLY	3 MONTHS						
Clean and Wax; All Glossy Finishes	6 MONTHS	YEARLY						
Repack with Grease; Linear Bearings	6 MONTHS	YEARLY						
Replace; Cables, Belts and Connecting Parts	YEARLY	3 YEARS						

Your equipment comes with a commercial maintenance decal. For personal, in home use, please follow the home maintenance schedule listed above.

General Maintenance Information

Links, Pull-Pins, Snap Hooks, Swivels, Weight Stack Pins:

- * Check all pieces for signs of visible wear or damage.
- * Check springs in snap hooks and pull-pins for proper tension and alignment.
- * If the spring sticks or has lost its rigidity, replace it immediately.

Upholstery:

- * To ensure prolonged upholstery life and proper hygiene, all upholstered pads should be wiped down with a damp cloth after every workout.
- * Periodically take the time to use a mild soap or an approved vinyl upholstery cleaner to deter the onset of cracking or drying. Avoid using any abrasive cleaners or cleaners not intended for use on vinyl.
- * Replace ripped or worn upholstery immediately.
- * Keep sharp or pointed objects clear of all upholstery.

Decals:

- * Inspect and familiarize yourself with any safety warnings or other user information posted on each decal.

Nuts and Bolts:

- * Inspect all nuts and bolts for any loosening and tighten if needed.
- * Go through a re-tightening sequence periodically to ensure that all hardware is tensioned proper.

Anti-Skid Surfaces:

- * These surfaces are designed to supply secure footing and need to be replaced if they appear worn or become slippery.

Belts and Cables:

- * We use only high quality belt, and mil-spec cables.
- * Visually inspect the belts and cables for fraying, cracking, peeling or discoloration.
- * While the machine is not in use, carefully run your fingers along the belt or cable to feel for thinning or bulging areas.
- * Replace belts and cables immediately at the first signs of damage or wear. Do not use equipment until belts or cables have been replaced.

Belt and Cable Tension:

- * Referring to the Owners Manual, when belts or cables are used check all bolts attachments to be sure they are properly attached.
- * Check slack in cables and re-adjust cable tension if needed.

Seat Sleeves, Guide Rods:

- * Wipe down adjusting tubes with a dust free rag before applying lubricant.
- * Lubricate seat sleeves and Guide Rods with a Silicon or Teflon based lubricant spray.

Linear Bearings:

- * Referring to the Owners Manual carefully disassemble the bearing from its housing and place a finger full of light grease (lithium, super lube, etc.) into the inside of the bearing. Using your finger, press the grease into the ball-bearings and their tracks. repeat until the ball-bearing tracks are full of grease. Insert the shaft back into the bearing and wipe off excess grease.

PLEASE KEEP THIS FOR YOUR RECORDS

Weight Training Tips

Use this manual to guide you through the basic exercises you can perform on your equipment. To gain maximum results and avoid possible injury, consult a fitness professional to develop your complete exercise program.

Always consult your physician before starting any exercise program.

To be successful in your exercise program, it is important to develop an understanding of the basic principles of strength training. Now that you have your equipment, it is only natural that you want to get started immediately. First, determine a set of realistic goals and objectives for yourself. By deciding on an exercise plan that is right for you prior to starting, you will contribute significantly to your success.

Warm up properly before engaging in weight resistance training. Stretching, yoga, jogging, calisthenics or other cardiovascular exercise can help prepare your body for the heavier workload of lifting weights.

Learn how to perform the exercise correctly before using heavy weight. Correct form is important to avoid injury and to ensure that you work the proper muscle groups.

Know your limitations. If you are new to weight training or are embarking on an exercise regimen after a long layoff, start slowly and build foundational strength over a longer period of time.

Pay attention to your breathing. Exhale when you exert is a general rule of thumb. Never hold your breath.

