



FE9705

LEG EXTENSION

OWNER'S MANUAL

Rev A1 17ZV6

CAUTION! Read all precautions and instructions in this manual before using this equipment.

Table Of Contents

CAUTION!

Read all precautions and instructions in this manual before using this equipment.

Important Safety Instructions-----	3
Instructions-----	5
Exploded View and Parts List-----	6
Measurement Guide-----	24
Assembly Instructions-----	25
Assembly-----	26
Adjust Instructions-----	40
Exercise Instructions-----	41
Console Panel Function-----	42
Battery Replacement-----	43
Maintenance Schedule-----	44
General Maintenance Information-----	45
Weight Training Tips-----	46

Please assemble according to the actual **Weights** you buy !

Important Safety Instructions

Before beginning any fitness program, you should obtain a complete physical examination from your physician. When using exercise equipment, basic precautions should always be taken, including the following:

1. Read all instructions before using the equipment.
These instructions are written to ensure your safety and to protect the unit.
2. Use the equipment only for its intended purpose as described in this guide.
Do not use accessory attachments that are not recommended by the manufacturer: such attachments might cause injuries.
3. The product should only be used on a level surface and is with 0.5 meters space around the product.
Do not use the equipment outdoors.
4. Do not allow children on or near the equipment. And children are not allowed to use this equipment.
Teenagers should use this equipment with adult supervision.
5. Do not overexert yourself or work to exhaustion.
Do not attempt to lift more weight than you can control safely.
If you feel any pain or abnormal symptoms, stop your workout immediately and consult your physician.
6. This equipment is not used as medical apparatus and instruments.
7. Never operate the unit when it has been dropped or damaged.
Never drop or insert anything into any opening in the equipment.
Always check the unit and its cables before each use. Make sure that all fasteners and cables are secure and in good working condition.
Frayed or worn cables can be dangerous and may cause injury. Periodically check these cables for any indication of wear.
Keep hands, limbs, loose clothing and long hair well out of the way of moving parts.
8. Be careful when getting on or off the equipment.
9. Wear proper exercise clothing and shoes for your workout, no loose clothing.

Important Safety Instructions

Personal Safety During Assembly

Read each step in the assembly instructions and follow the steps in sequence. Do not skip ahead. If you skip ahead, you may learn later that you have to disassemble components and that you may have damaged the equipment.

Assemble and operate the equipment on a solid, level surface. Locate the unit a few feet from walls or furniture to provide easy access. The equipment is designed for your enjoyment. By following these precautions and using common sense, you will have many safe and pleasurable hours of healthful exercise with the equipment.

Training Area and Free Area

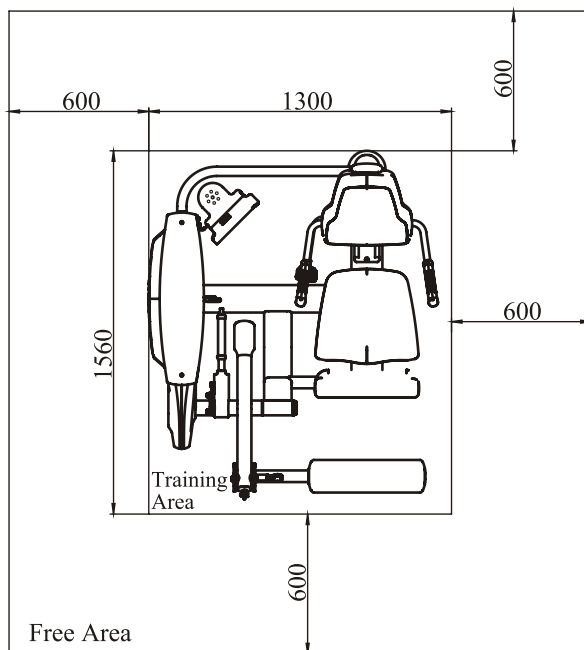

Specifications

Class: S

Maximum Wt. Capacity: 134kg/ 295lbs

Maximum User Weight: 150kg/ 330lbs

Product Total Surface: 1300*1560mm

Product Total Mass: 169.6kg/ 374lbs

Instructions

Before beginning assembly please take the time to read instructions thoroughly. Please use the various lists in this manual to make sure that all parts have been included in your shipment. When ordering, use part number and description from the lists. Use only our replacement part when servicing. Failure to do so will void your warranty and could result in personal injury.

The equipment is designed to provide the smoothest, most effective exercise motion possible. After assembly, you should check all functions to ensure correct operation. If you experience problems, first recheck the assembly instructions to locate any possible errors made during assembly. If you are unable to correct the problem, call your authorized dealer. Be sure to have your serial number and this manual when calling. When all parts have been accounted for, continue on.

Tools Required



Ratchet Wrench and Socket



Adjustable Wrench



Rubber Mallet

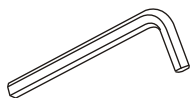

Hex Key Wrench Set



Phillips Screwdriver

Exploded View and Parts List

Weight Stack Frame Assy

Item No.	Grade No.	Part No.	Description	QTY
1	1.1	FE97050100V1	Weight Stack Frame	1
2	1.2	FE97211200	Top Clamping Plate	1
3	1.3	FE97211300	Limiting Plate	1
4	1.4	FE97122000	Plate For Sensor	1
5	1.5	FE97123000	Cover For Magnetic Iron	1
6	1.6	FE97011500	Foot Plate	2
7	1.7	FE97123900	Belt Pulley Φ 76	2
8	1.8	SG500110400V2	4.5" Pulleys	1
9	1.9	PBE10008	Spacer Φ 10.2* Φ 14*6	2
10	1.10	IE951814700	Magnetic Iron	2
11	1.11	DQCGQ01	Sensor	2
12	1.12	DQDCH02	Cell Box	1
13	1.13	SMJ20*1*1000	Double Faced Adhesive Tape	0.1
14	1.14	GB17880.5M8*16.5DCS17	Rivet Nut M8	4
15	1.15	GB17880.5M6*16.5DS17	Rivet Nut M6	4
16	1.16	GB70BTM10*75DN18	Socket Head Cap Screw M10*75	2
17	1.17	GB5780M10*55DN20	Hex Head Bolt M10*55	1
18	1.18	PNLM8*25DN20NL	Button Head Cap Screw M8*25	2
19	1.19	PNLM6*12DN20	Button Head Cap Screw M6*12	4
20	1.20	GB818M3*8DS2	Screw M3*8	4
21	1.21	GB846ST2.9*9.5DS	Screw ST2.9*9.5	4
22	1.22	NM10DN2	Nylon Lock Nut M10	3
23	1.23	GB9510DN2	Flat Washer Φ 11* Φ 20*2	4
24	1.24	GB956DN2	Flat Washer Φ 6.6* Φ 12* 1.6	4
25	1.25	GB936N19	Spring Washer Φ 6	4
26	1.26	AC32705800	U-nut M6	6
27	1.27	YDMJ12*2*30	Hard Single-sided Adhesive Tape	6

Exploded View and Parts List

Weight Stack Frame Assy

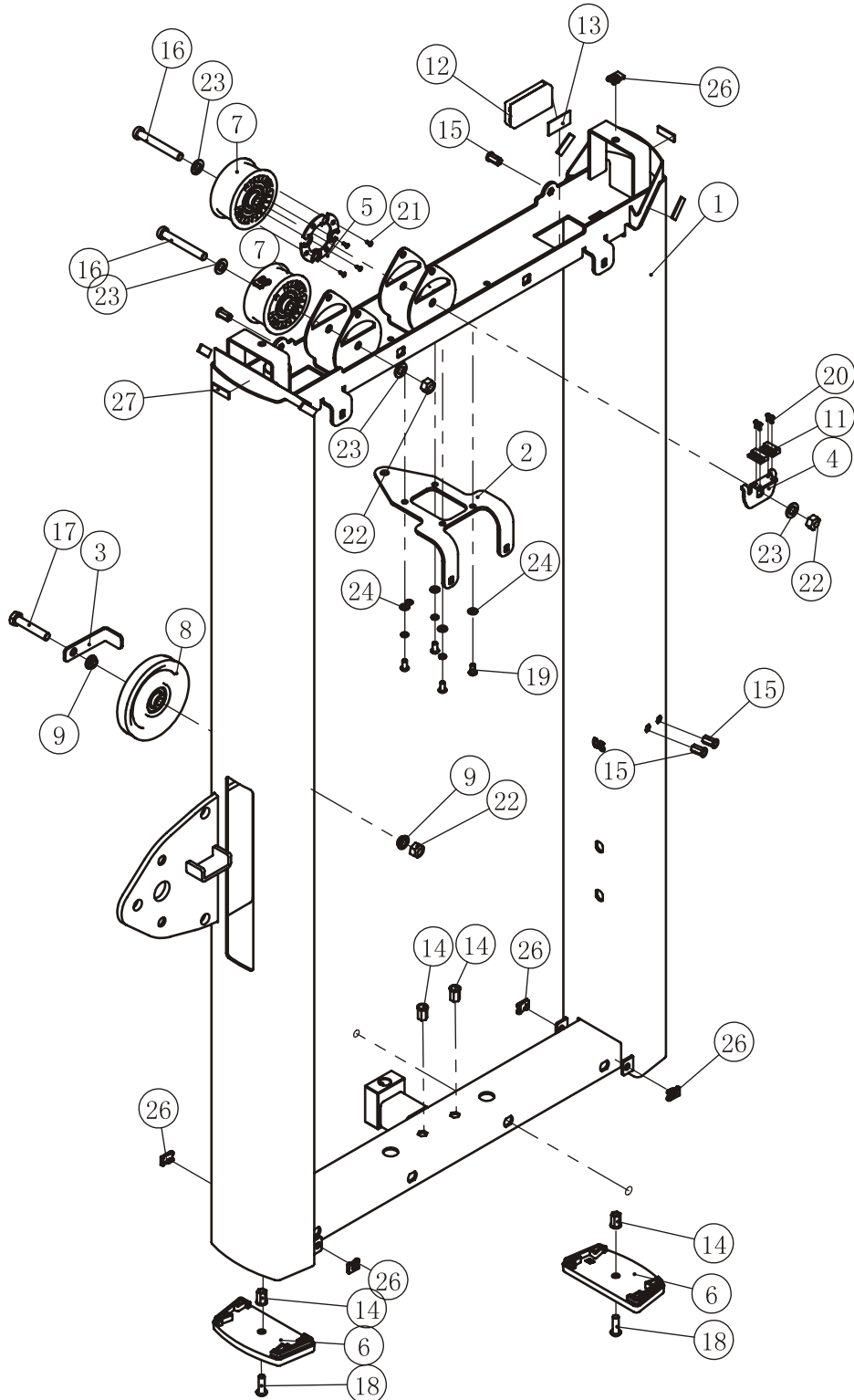

Exploded View and Parts List

Main Frame ASSY

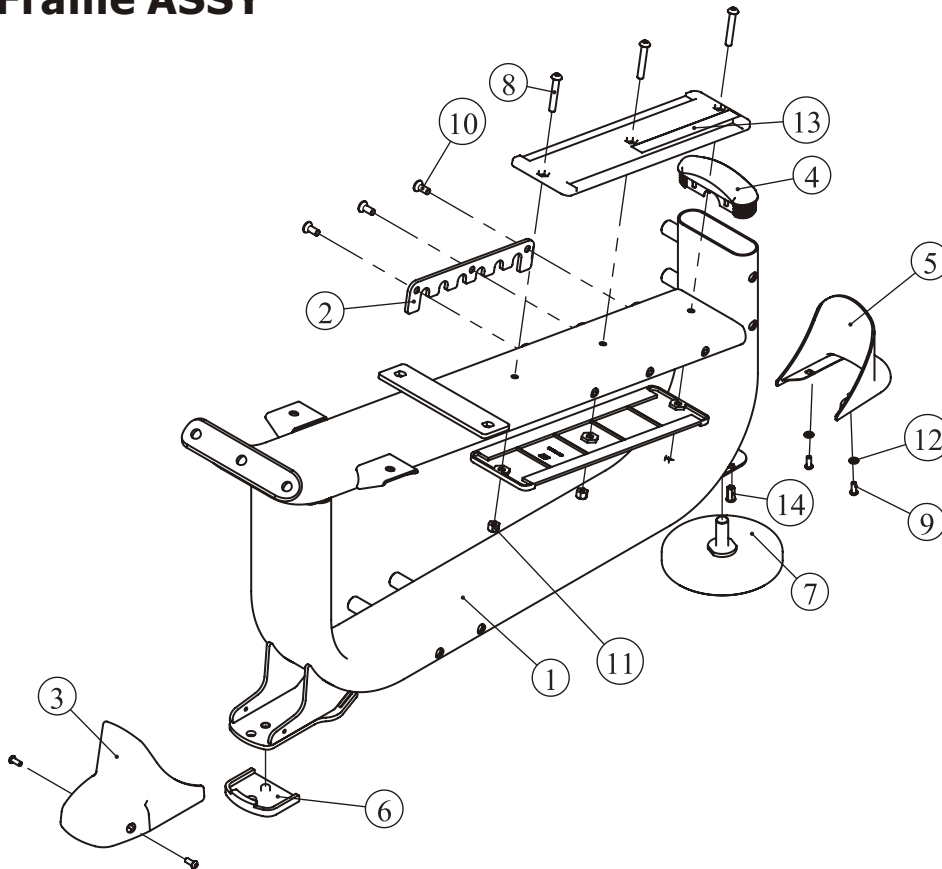

Item No.	Grade No.	Part No.	Description	QTY
1	2.1	FE97 050 200	Main Frame	1
2	2.2	FE97 051 100	Adjusting Gear Plate	1
3	2.3	FE97 052 300	Front Cover	1
4	2.4	FE97 211 500	Plug RT40*133*3	1
5	2.5	FE97 211 700	Rear Ground Plastic Cover	1
6	2.6	FE97 211 800	Rubber Foot	1
7	2.7	IT932 01800	Adjustable Foot Plate	1
8	2.8	PNLM 8*50 DN20	Button Head Cap Screw M8*50	3
9	2.9	PNLM 6*15 DN20	Button Head Cap Screw M6*15	4
10	2.10	CNLM 8*20 DN20NL	Flat Head Cap Screw M8*20	3
11	2.11	NM8 DN2	Nylon Lock Nut M8	3
12	2.12	GB956 DN2	Flat Washer Φ 6.6 * Φ 12 * 1.6	2
13	2.13	FE97 052 400	Roller Press	2
14	2.14	GB1 7880.5M6*16.5DS17	Rivet Nut M6	2

Exploded View and Parts List

Front Support Frame ASSY

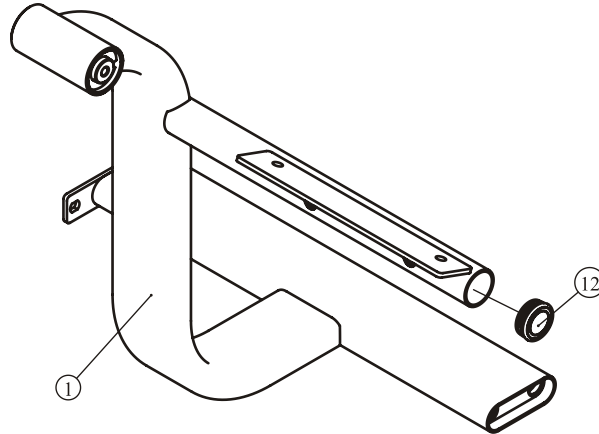

ItemNo.	Grade No.	Part No.	Description	QTY
1	3.1	FE97050300	Front Support Frame	1
2	3.2	PBF40013	Plug Φ 50*18.5	1

Double Handle Frame ASSY

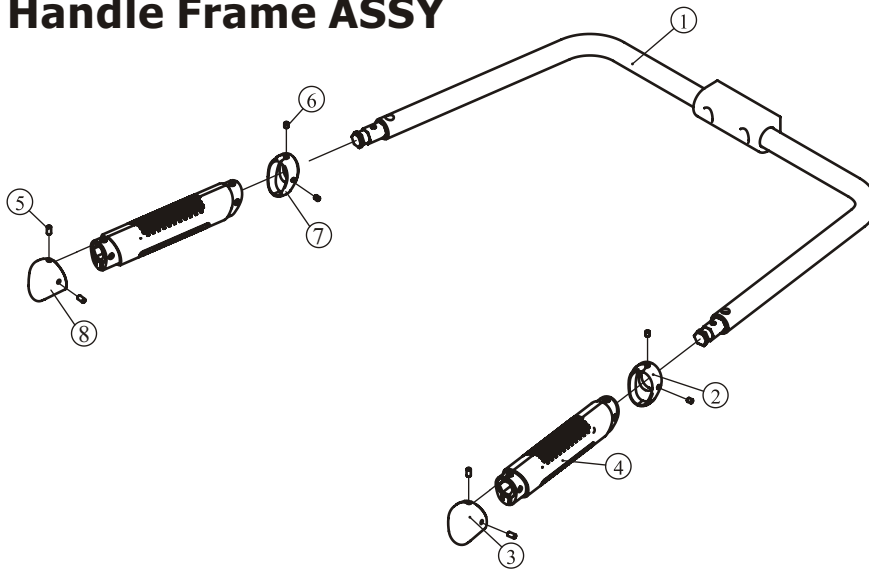

Item No.	Grade No.	Part No.	Description	QTY
1	6.1	FE97 050 600	Double Handle Frame	1
2	6.2	FE97 011 4500	Aluminium Grip Ring	1
3	6.3	FE97 011 4600	Aluminium Grip Cap	1
4	6.4	FE97 211 4700	Grip	2
5	6.5	GB7 7M5 *10N19	Screw M5*10	4
6	6.6	GB7 7M5 *6N19	Screw M5*6	4
7	6.7	FE97 011 4500V1	Aluminium Grip Ring Right	1
8	6.8	FE97 011 4600V1	Aluminium Grip Cap Right	1

Exploded View and Parts List

Back Pad Frame ASSY

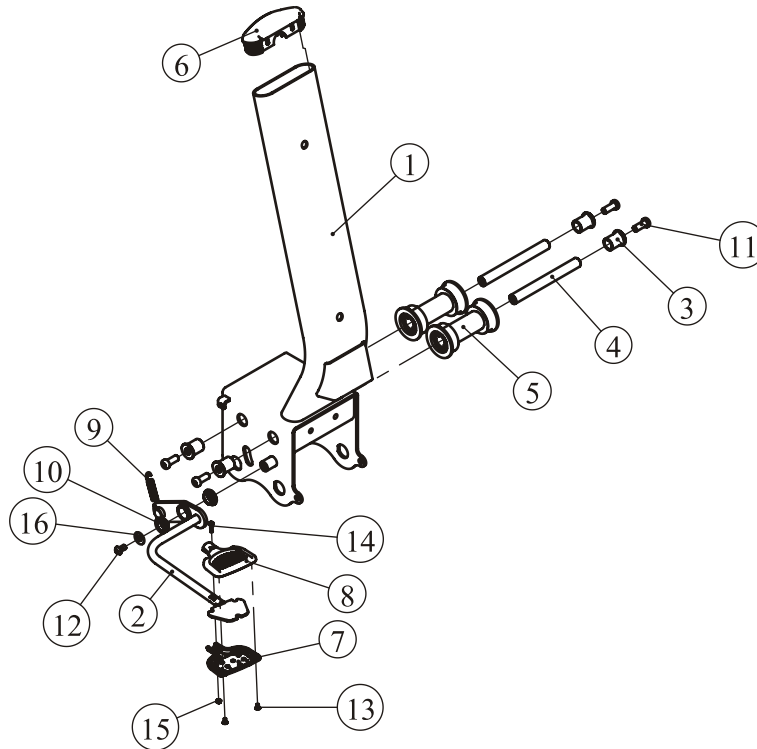

ItemNo.	Grade No.	Part No.	Description	QTY
1	5.1	FE97050500	Back Pad Frame	1
2	5.2	FE97050700	Regulation Handle	1
3	5.3	FE97051300	Long Sleeve $\Phi 28 * \Phi 17.2 * 29.6$	4
4	5.4	FE97051600	Screw Shaft $\Phi 17 * 157$	2
5	5.5	FE970539ASSY	Roller ASSY	2
6	5.6	FE97211500	Plug RT40*133*3	1
7	5.7	FE970114100	Under The Cover	1
8	5.8	FE970114200	Adjust The Cover	1
9	5.9	KPSFID2400	Drag Spring $\Phi 1.5 * \Phi 13 * 43$	1
10	5.10	C011PL1900	Bushing $\Phi 28 * 8.5$	2
11	5.11	GB70BTM10*25DN18NL	Socket Head Cap Screw M10*25	4
12	5.12	PNLM8*15DN20	Button Head Cap Screw M8*15	1
13	5.13	GB819M4*8DN2	Screw M4*8	2
14	5.14	GB818M4*16DN2NL	Screw M4*16	1
15	5.15	GB41M4DN2	Hex Nut M4	1
16	5.16	DQ8DN2	Flat Washer $\Phi 9 * \Phi 22 * 1.6$	1

Exploded View and Parts List

Cam Frame ASSY

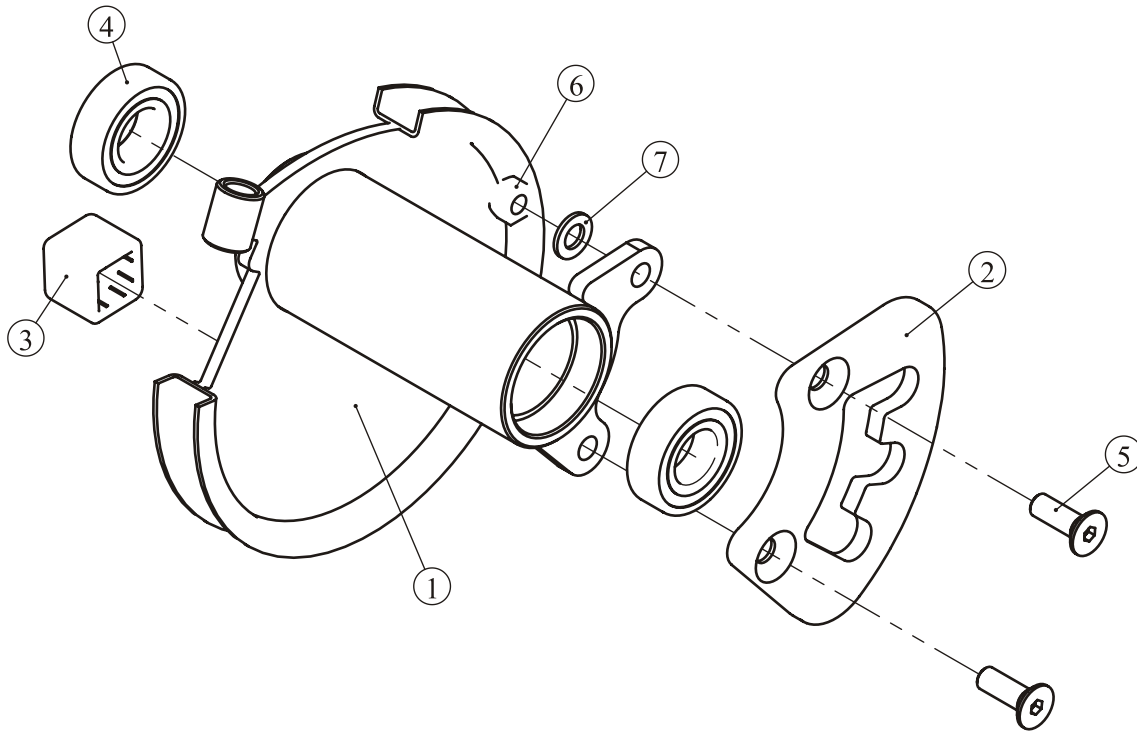

ItemNo.	Grade No.	Part No.	Description	QTY
1	7.1	FE97050800	Cam Frame	1
2	7.2	FE97213000	Fanshaped Adjustment Plate	1
3	7.3	FE97213100	Square Rubber Sleeve	1
4	7.4	GB2766205-2ZNBK	Bearing 6205-2Z	2
5	7.5	CNLM10*30*30DN20	Flat Head Cap Screw M10*30	2
6	7.6	NM10DN2	Nylon Lock Nut M10	2
7	7.7	GB9510DN2	Flat Washer Φ11*Φ20*2	2

Exploded View and Parts List

Swing Frame ASSY

ItemNo.	Grade No.	Part No.	Description	QTY
1	8.1	FE97050900	Swing Frame	1
2	8.2	FE97052100	Left Cover	1
3	8.3	FE97052200	Right Cover	1
4	8.4	FE97211900	Cap Φ 60	1
6	8.6	FE97212200	Strength Transfer Rod	1
7	8.7	FE97212300	Pin Axle	1
8	8.8	FE97212400	Press Button	1
9	8.9	026-01PL0206-14	Grip Φ 31* Φ 24*160	1
10	8.10	FE97212600	Aluminium Grip Cap Φ 34* Φ 15*16	1
11	8.11	FE97212700	Aluminium Grip Ring Φ 34* Φ 26.2*15	1
12	8.12	FE97212900	Scaleboard	1
13	8.13	M02502000	Bushing Φ 38* Φ 25.4*18	2
14	8.14	SG8007M1200B	Spring Φ 1.5* Φ 13*64	1
15	8.15	GB2766205-2ZNBK	Bearing 6205-2Z	2
16	8.16	IN-S10111200	Rubber Sleeve Φ 17*10.5	2
17	8.17	GB70BTM10*16DN18NL	Socket Head Cap Screw M10*16	1
18	8.18	GB70M8*20DN20	Socket Head Cap Screw M8*20	2
19	8.19	PNLM4*10N19	Button Head Cap Screw M4*10	2
20	8.20	GB77M5*4N19	Screw M5*4	4
21	8.21	NM8DN2	Nylon Lock Nut M8	2
22	8.22	GB958DN2	Flat Washer Φ 9* Φ 16*1.6	2
23	8.23	GB70M8*25DN20	Socket Head Cap Screw M8*25	1

Exploded View and Parts List

Swing Frame ASSY

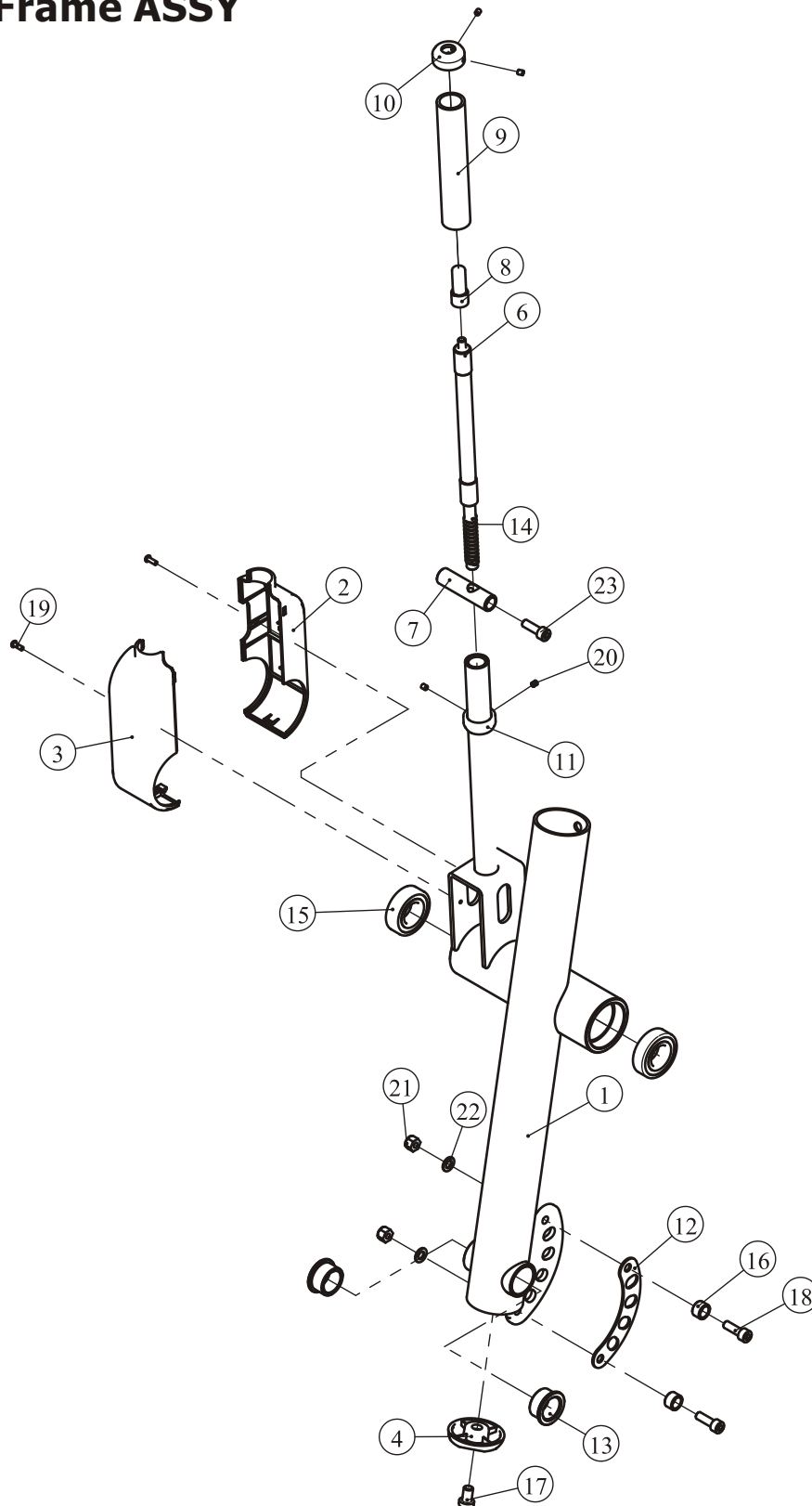

Exploded View and Parts List

Training Placard Cover ASSY

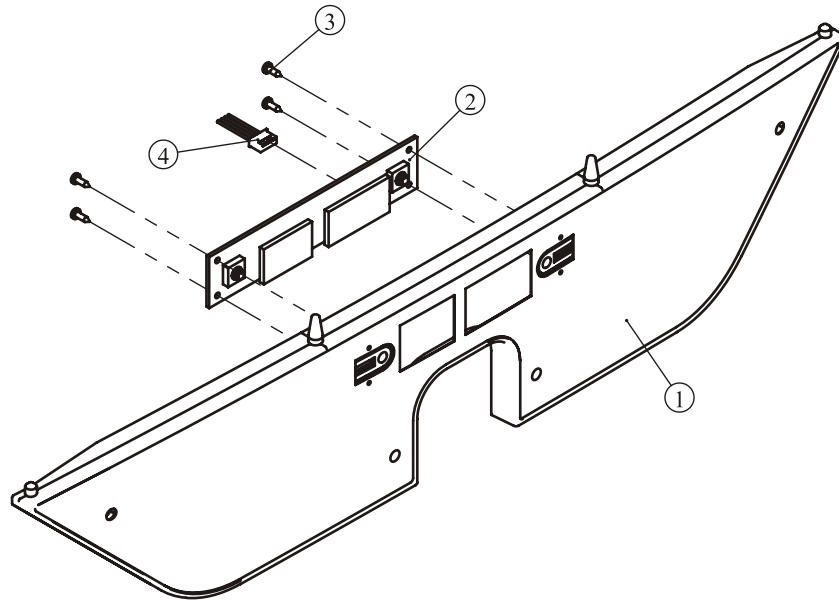

ItemNo.	Grade No.	Part No.	Description	QTY
1	16.1	FE97052600	Training Placard Cover	1
2	16.2	B117	Console PCB	1
3	16.3	GB845ST2.9*9.5DS	Screw ST2.9*9.5	4
4	16.4	L350XHP/SMY-4	Sensor 4C*22#350mm	1

Foam Frame ASSY

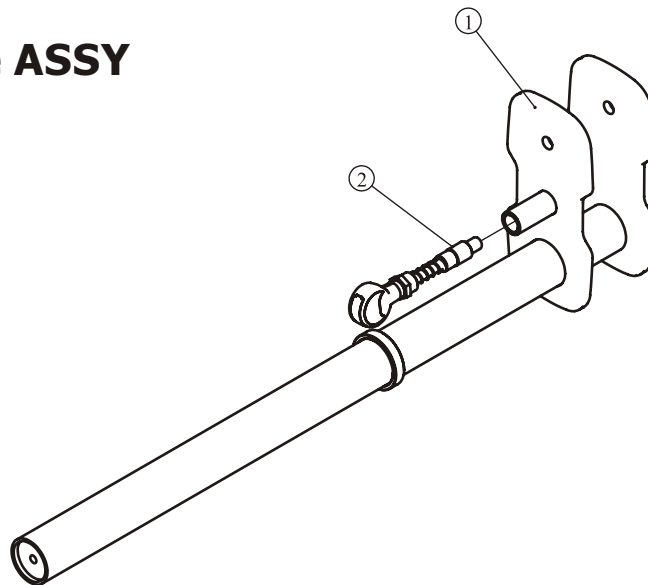

ItemNo.	Grade No.	Part No.	Description	QTY
1	27.1	FE97210500	Foam Frame	1
2	27.2	FE97211000	Position Adjustment Pin	1

Exploded View and Parts List

Flange ASSY

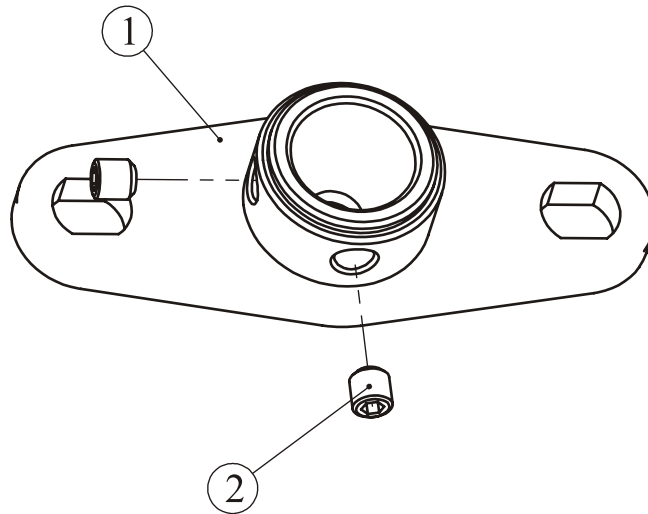

ItemNo.	Grade No.	Part No.	Description	QTY
1	28.1	FE97210800	Flange	1
2	28.2	GB77M8*8DS18	Screw M8*8	2

5LBS Counter Weight ASSY

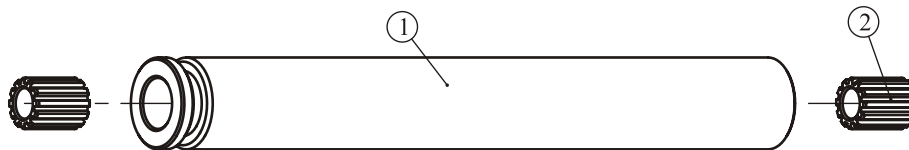

ItemNo.	Grade No.	Part No.	Description	QTY
1	55.1	FE97213500	5LBS Counter Weight	1
2	55.2	CXT-1001900V1	Guide Sleeve $\Phi 25^* \Phi 15^* 32$	2

Exploded View and Parts List

Belt ASSY

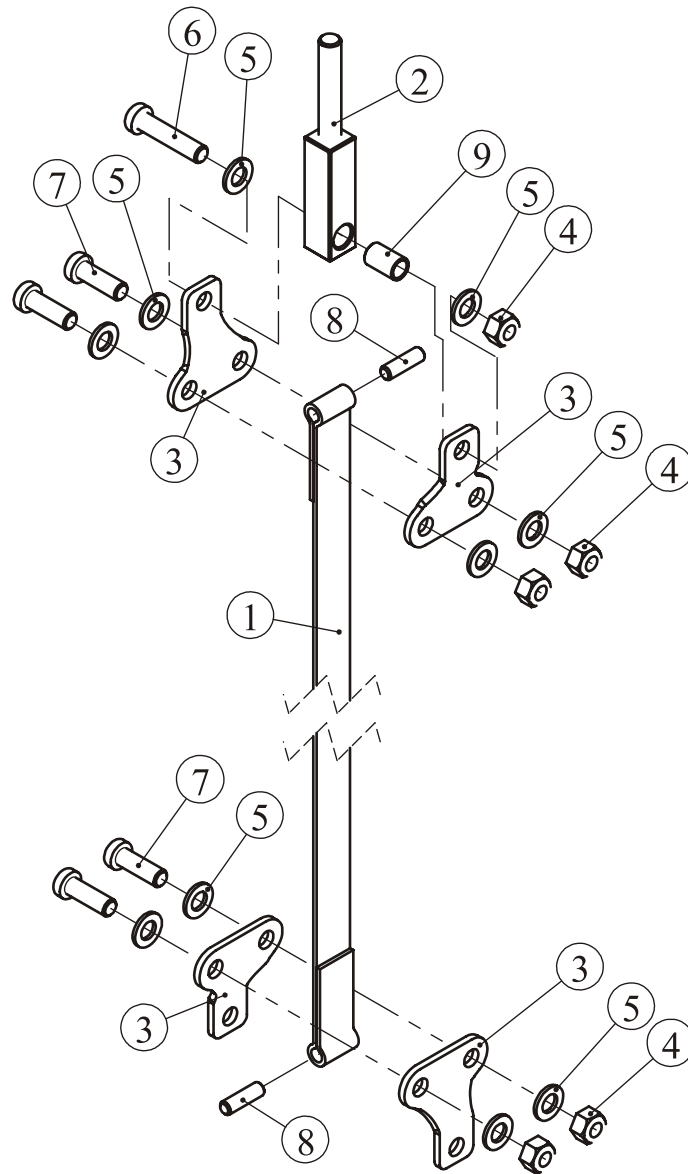

ItemNo.	Grade No.	Part No.	Description	QTY
1	36.1	FE97214500	Belt	1
2	36.2	FE97214700	Square Adjustment Lever	1
3	36.3	FE97193300	Fastening Plate	4
4	36.4	NM10DN2	Nylon Lock Nut M10	5
5	36.5	GB9510DN2	Flat Washer $\Phi 11 * \Phi 20 * 2$	10
6	36.6	GB70BTM10*45DN18	Socket Head Cap Screw M10*45	1
7	36.7	GB70BTM10*30DN18	Socket Head Cap Screw M10*30	4
8	36.8	FE97024501	Locating Pin $\Phi 8 * 42$	2
9	36.9	FE972111500	Spacer $\Phi 13 * \Phi 10.3 * 21$	1

Exploded View and Parts List

Top Plate ASSY

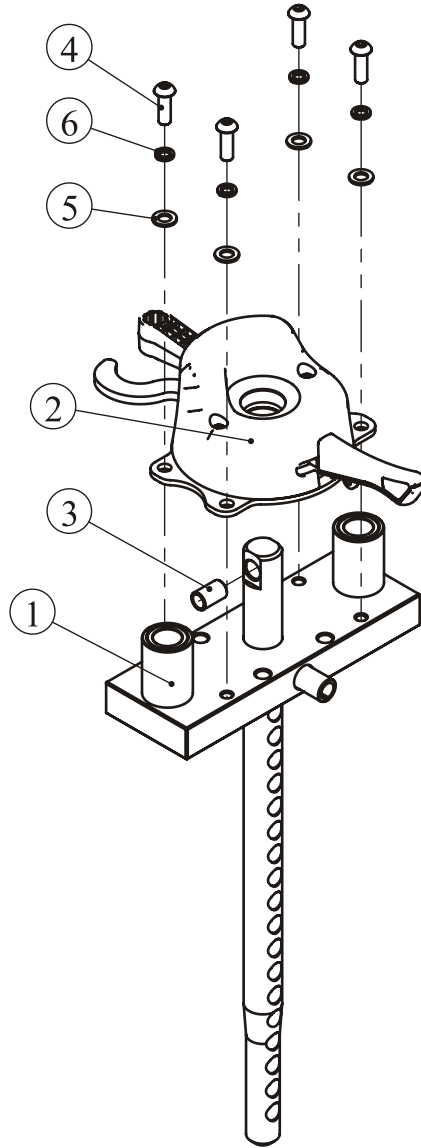

ItemNo.	Grade No.	Part No.	Description	QTY
1	44.1	FE97193000	Top Plate	1
2	44.2	FE971938ASSY	Counter Weight ASSY	1
3	44.3	FE972111500	Spacer $\Phi 13 * \Phi 10.3 * 21$	1
4	44.4	PNLM8*25DN20	Button Head Cap Screw M8*25	4
5	44.5	GB958DN2	Flat Washer $\Phi 9 * \Phi 16 * 1.6$	4
6	44.6	GB938N19	Spring Washer $\Phi 8$	4

Exploded View and Parts List

Counter Weight ASSY

ItemNo.	Grade No.	Part No.	Description	QTY
1	44.2.1	FE97192700	Plastic Base	1
2	44.2.2	FE97192800	Counter Weight Plastic Cover	1
3	44.2.3	FE97193500	Base Plate	1
4	44.2.4	FE97193600	Shifting Fork	1
5	44.2.5	FE97193700	Top Plate	1
6	44.2.6	FE97193800	Guide Frame	1
7	44.2.7	FE97193900	Short Spacer $\Phi 45 * \Phi 26 * 7.5$	1
8	44.2.8	FE97194000	Stop Collar	1
9	44.2.9	FE97194100	Top Plastic Cover	1
10	44.2.10	FE97194200	Base Plastic Cover	1
11	44.2.11	CWRVL0251800	Steel Ball Support Base	2
12	44.2.12	CWRVL0251900	Spring $\Phi 1.2 * \Phi 13 * 11$	3
13	44.2.13	GB3088G20	Steel Ball	2
14	44.2.14	PNLM8*80DN20	Button Head Cap Screw M8*80	2
15	44.2.15	PNLM8*45DN20	Button Head Cap Screw M8*45	2
16	44.2.16	PNLM4*12DN20	Button Head Cap Screw M4*12	2
17	44.2.17	PNLM5*15DN20	Button Head Cap Screw M5*15	2
18	44.2.18	GB958DN2	Flat Washer $\Phi 9 * \Phi 16 * 1.6$	4
19	44.2.19	GB938N19	Spring Washer $\Phi 8$	4

Exploded View and Parts List

Counter Weight ASSY

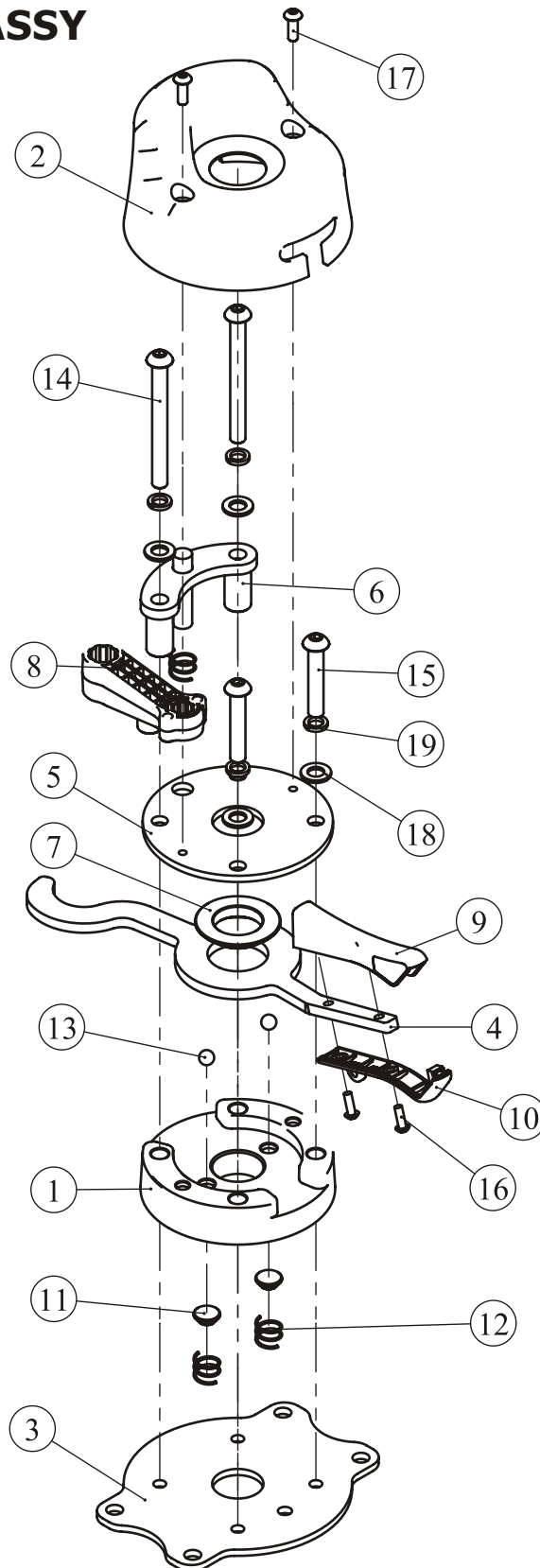

Exploded View and Parts List

Back Pad ASSY

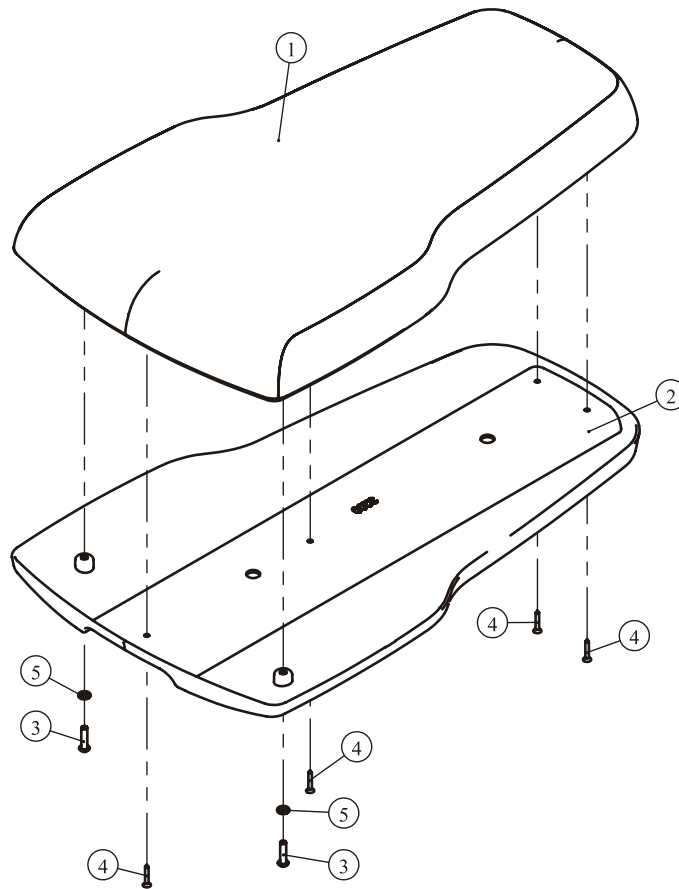

ItemNo.	Grade No.	Part No.	Description	QTY
1	48.1	FE97123100	Back Pad	1
2	48.2	FE97123200	Back Pad Cover	1
3	48.3	PNLM6*25*25N19	Button Head Cap Screw M6*25	2
4	48.4	GB846ST3.5*25DN	Screw ST3.5*25	4
5	48.5	GB956DN2	Flat Washer $\Phi 6.6 * \Phi 12 * 1.6$	2

Exploded View and Parts List

Overall

Item No.	Grade No.	Part No.	Description	QTY
1	1	FE970501V1ASSY	Weight Stack Frame ASSY	1
2	2	FE970502ASSY	Main Frame ASSY	1
3	3	FE970503ASSY	Front Support Frame ASSY	1
4	4	FE97210400	Rear Cross Brace	1
5	5	FE970505ASSY	Back Pad Frame ASSY	1
6	6	FE970506ASSY	Double Handle Frame ASSY	1
7	7	FE970508ASSY	Cam Frame ASSY	1
8	8	FE970509ASSY	Swing Frame ASSY	1
9	9	FE97051200	Spring Shaft Φ 14*149	1
10	10	FE97051400	Adjustment Sleeve Φ 34* Φ 19*36.6	4
11	11	FE97051500	Tension Spring	1
12	12	FE97051700	Long Threaded Shaft Φ 17*177	2
13	13	FE97051800	Front Seat Pad	1
14	14	FE97051900	Wide Seat Pad	1
15	15	FE97052500	Front Shroud	2
16	16	FE970526ASSY	Training Placard Cover ASSY	1
17	17	FE9705270005	Front Lower Cover	1
18	18	FE97052800	Back Shroud	1
19	19	FE97052900	Back Lower Cover	1
20	20	FE97053100	Cable	1
21	21	FE97053200	Back CAM Cover	1
22	22	FE97053300	Front CAM Cover	1
23	23	FE97053400	Accessory Plastic Plate	1
24	24	FE97053500	Cup Holder	1
25	25	FE97053600	Bracket of Cup Holder	1
26	26	FE97053700	Plastic End Cap	1
27	27	FE972105ASSY	Foam Frame ASSY	1
28	28	FE972108ASSY	Flange ASSY	1
29	29	FE97210900	Bracket of Belt Pulley	1
30	30	FE97211400	Underside Support Plate	1
31	31	FE97211900	Cap Φ 60	2
32	32	FE97212000	Circle Ring Φ 62.5*5	1
33	33	FE97213200	Counter Weight	1
34	34	FE97213400	Rubber Sleeve Φ 30*65	2
35	35	FE97214000	Narrow Belt Pulley Φ 76	1
36	36	FE972145ASSY	Belt ASSY	1
37	37	FE97214800	Belt Rubber Sleeve Φ 17*49	2
38	38	FE97215000V1	Guide Rod Φ 19	2
39	40	FE97216900	Spacer Pin Φ 15* Φ 8*65.5	2
40	41	FE972111000V1	Main Shaft Φ 25	1
41	42	FE97192500	Plastic Cover I	2
42	43	FE97192600	Plastic Cover II	1
43	44	FE971930ASSY	Top Plate ASSY	1
44	45	FE97194300	Guide Rod Φ 14	1
45	46	FE97194400	Limiting Tube Φ 22*2*66	1
46	47	FE97011600V1	Top Cover	1
47	48	FE971231ASSY	Back Pad ASSY	1
48	49	FE97123800	Selector Pin W/Coil	1

Exploded View and Parts List

Overall

Item No.	Grade No.	Part No.	Description	QTY
49	50	FE972152ASSY	Leather Wrapped Round Foam	1
50	51	FE970539ASSY	Roller ASSY	2
51	52	IN-D10132900	Plug Bumper $\Phi 76 \times 60$	2
52	53	CWRVL0250900	Flat Washer $\Phi 15 \times \Phi 40 \times 3$	1
53	54	CWRVL0251000	Plug Bumper $\Phi 14 \times \Phi 40 \times 2.4$	1
54	55	FE971949ASSY	7.5LBS Counter Weight ASSY	1
55	56	FE97211100	Seat Pad Support Plate	1
56	57	C170C1700	Flange Gasket $\Phi 35 \times \Phi 25.4 \times 2$	2
57	58	IT80031100	Small End Cover $\Phi 34 \times 5$	4
60	62	GB70BTM12*180DN18NL	Socket Head Cap Screw M12*180	4
61	63	GB70BTM12*120DN18NL	Socket Head Cap Screw M12*120	2
62	64	GB70BTM12*105DN18	Socket Head Cap Screw M12*105	2
63	65	GB70M8*45*45N19	Socket Head Cap Screw M8*45	2
64	66	GB70BTM12*30DN18	Socket Head Cap Screw M12*30	2
65	67	GB70BTM10*100DN18	Socket Head Cap Screw M10*100	1
66	68	GB70BTM10*65DN18	Socket Head Cap Screw M10*65	3
67	69	GB70BTM10*45DN18	Socket Head Cap Screw M10*45	4
68	70	GB70BTM10*25DN18NL	Socket Head Cap Screw M10*25	13
69	71	GB70M8*25DN20	Socket Head Cap Screw M8*25	2
70	72	PNLM8*25DN20	Button Head Cap Screw M8*25	2
71	73	PNLM8*15DN20	Button Head Cap Screw M8*15	2
72	74	PNLM6*20DN20	Button Head Cap Screw M6*20	13
73	75	PNLM6*15DN20	Button Head Cap Screw M6*15	6
74	76	CNLM12*35DN20	Flat Head Cap Screw M12*35	2
75	77	CNLM10*25DN20	Flat Head Cap Screw M10*25	4
76	78	GB77M8*8DS18	Screw M8*8	1
77	79	GB77M6*8DS18	Screw M6*8	8
78	80	NM12DN2	Nylon Lock Nut M12	5
79	81	NM10DN2	Nylon Lock Nut M10	5
80	82	GB9512DN2	Flat Washer $\Phi 13 \times \Phi 24 \times 2.5$	15
81	83	GB9510DN2	Flat Washer $\Phi 11 \times \Phi 20 \times 2$	18
82	84	GB958DN2	Flat Washer $\Phi 9 \times \Phi 16 \times 1.6$	8
83	85	GB956DN2	Flat Washer $\Phi 6.6 \times \Phi 12 \times 1.6$	19
84	86	DQ6DN2	Flat Washer $\Phi 6.6 \times \Phi 23 \times 2$	3
85	87	IN-D10132300V1	Cap $\Phi 43 \times \Phi 10.5 \times 8$	2
86	88	GB9310N19	Spring Washer $\Phi 10$	3
87	89	GB938N19	Spring Washer $\Phi 8$	4
88	90	GB936N19	Spring Washer $\Phi 6$	2
90	92	GB8966FH12	Shaft Ring Opening $\Phi 6$	2
91	93	NBS4DHS	Hex Key S=4	1
92	94	NBS5DHS	Hex Key S=5	1
93	95	NBS6DHS	Hex Key S=6	1
94	96	NBS8DHS	Hex Key S=8	1
95	97	NBS0.188DHS	Hex Key S=3/16"	1
96	98	LW200BS	Wrench $\Phi 6 \times 117$	1
97	99	YHY	Lube	1
98	100	PNLM6*12DN20	Button Head Cap Screw M6*12	5
99	101	NBS3DHS	Hex Key S=3	1
100	200	FE97214100V1	Shaft $\Phi 25.4 \times 92.5$	1
101	166	HFOPT900-04A0602	Tension Spring	2

Exploded View and Parts List

Overall

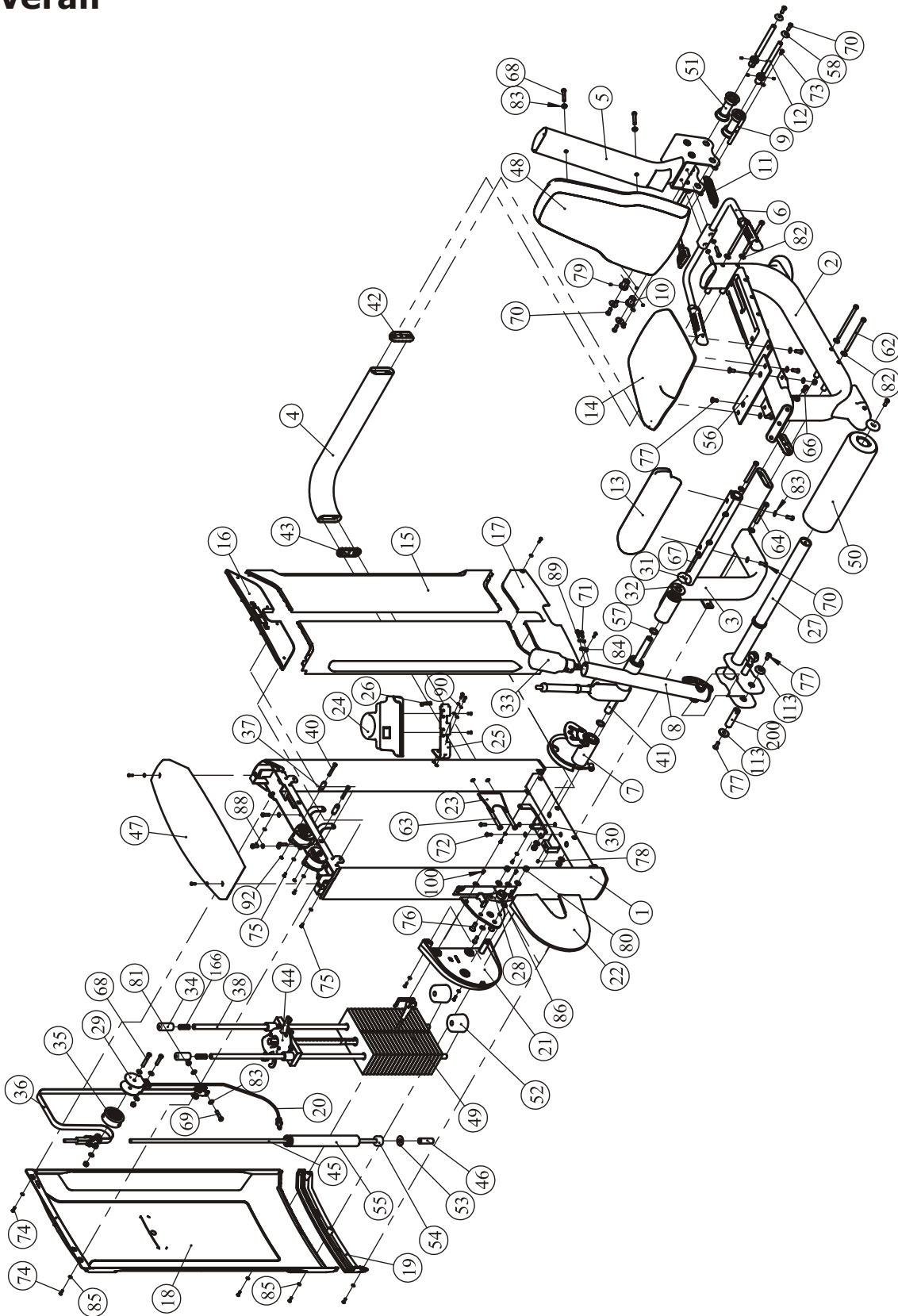

Measurement Guide

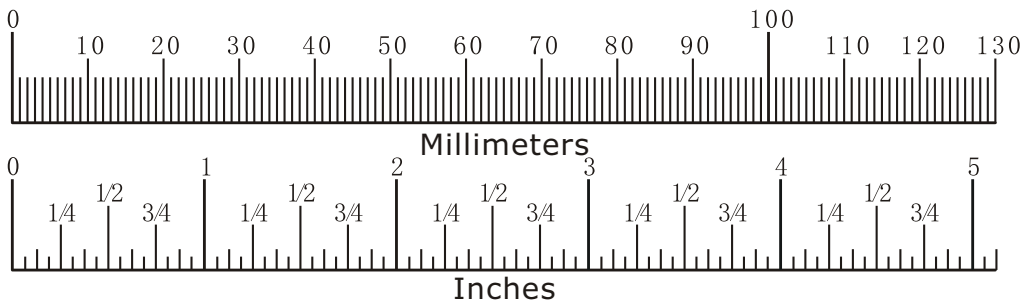
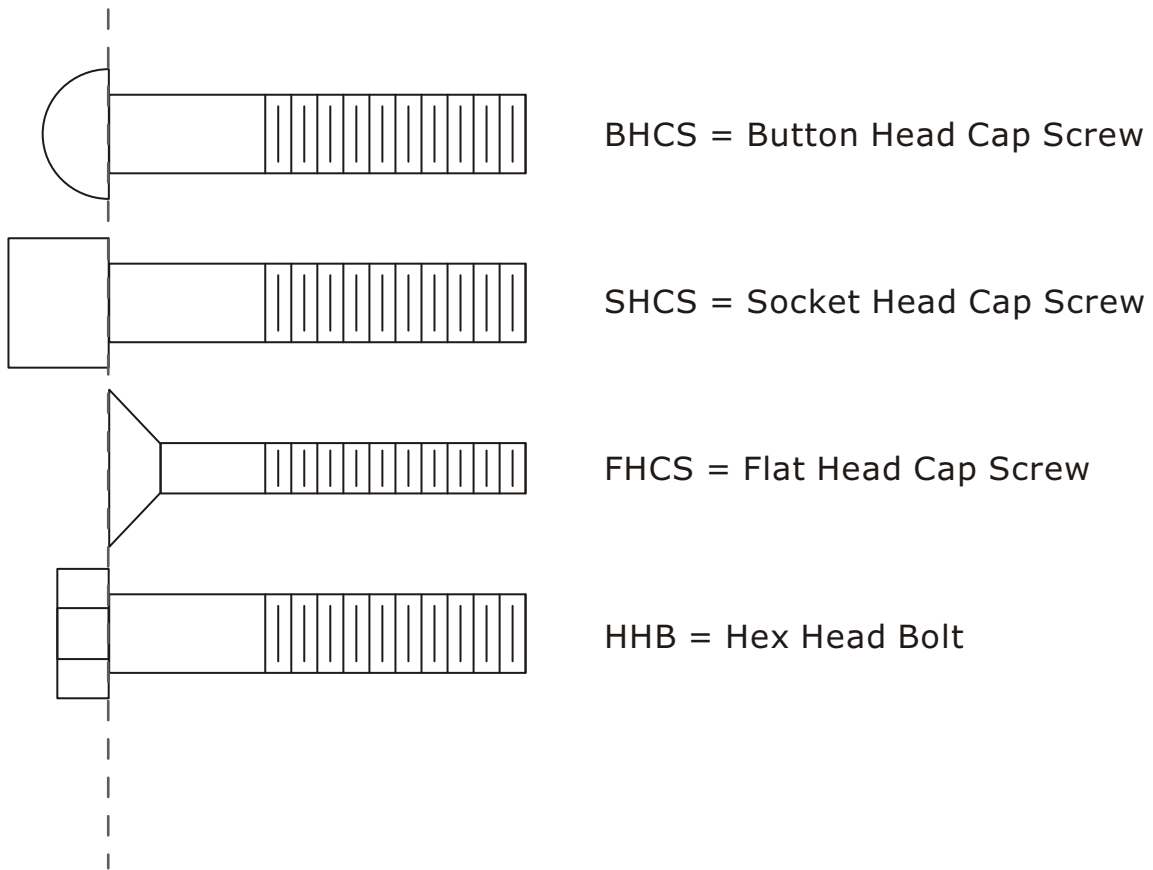

Diameter of bolt (mm/inch)	M6(1/4")	M8(5/16")	M10(3/8")	M12(1/2")	M16(5/8")
Tightening torque (N.m)	9~12	22~30	45~59	78~104	193~257
Operational methods for adult men	The strength of the wrist	The strength of the wrist and forearm	The strength of the entire arm	The strength of the arm and upper body	with all strength

Assembly Instructions

Assembly of the equipment takes professional installers about 2 hours. If this is the first time you have assembled this type of equipment, plan to spend more time. It is strongly recommended to assemble the equipment by professional installers. You may find it quicker, safer, easier to assemble this equipment with the help of a friend, as some of components may be large, heavy or awkward to handle alone. It is important that you assemble your product in a clean, clear, uncluttered area. This will enable you to move around the product while you are fitting components and reduce the possibility of injury during assembly.

NOTE

As with any assembled part, proper alignment and adjustment is critical. While tightening the fasteners, be sure to leave room for adjustments. Do not fully tighten the fasteners until instructed to do so. Be careful to assemble the components in the sequence presented in this guide.

Assembly

STEP 1

1. Attach The Swing Frame ASSY (#8) and The Cam Frame ASSY (#7) and The Flange ASSY (#28) to The Weight Stack Frame ASSY (#1) using:

one $\Phi 25$ Main Shaft (#41)

two $\Phi 35 \times \Phi 25.4 \times 2$ Flange Gaskets (#57)

two M12*35 FHCS (#76)

one M10*25 SHCS (#70)

one $\Phi 11 \times \Phi 20 \times 2$ Flat Washers (#83)

two M12 Nylon Lock Nut (#80)

two $\Phi 13 \times \Phi 24 \times 2.5$ Flat Washers (#82)

Note: Hand Tighten Bolts and Nylon Lock Nuts.

2. Attach The Front Support Frame ASSY (#3) to The Main Shaft (#41) and The Weight Stack Frame ASSY (#1) using:

two M12*105 SHCS (#62)

four $\Phi 13 \times \Phi 24 \times 2.5$ Flat Washer (#82)

two M12 Nylon Lock Nut (#80)

one M10*100 SHCS (#67)

one $\Phi 60$ Cap (#31)

one $\Phi 62.5 \times 5$ Circle Ring (#32)

Note: Do not tighten Bolts and Nylon Lock Nuts.

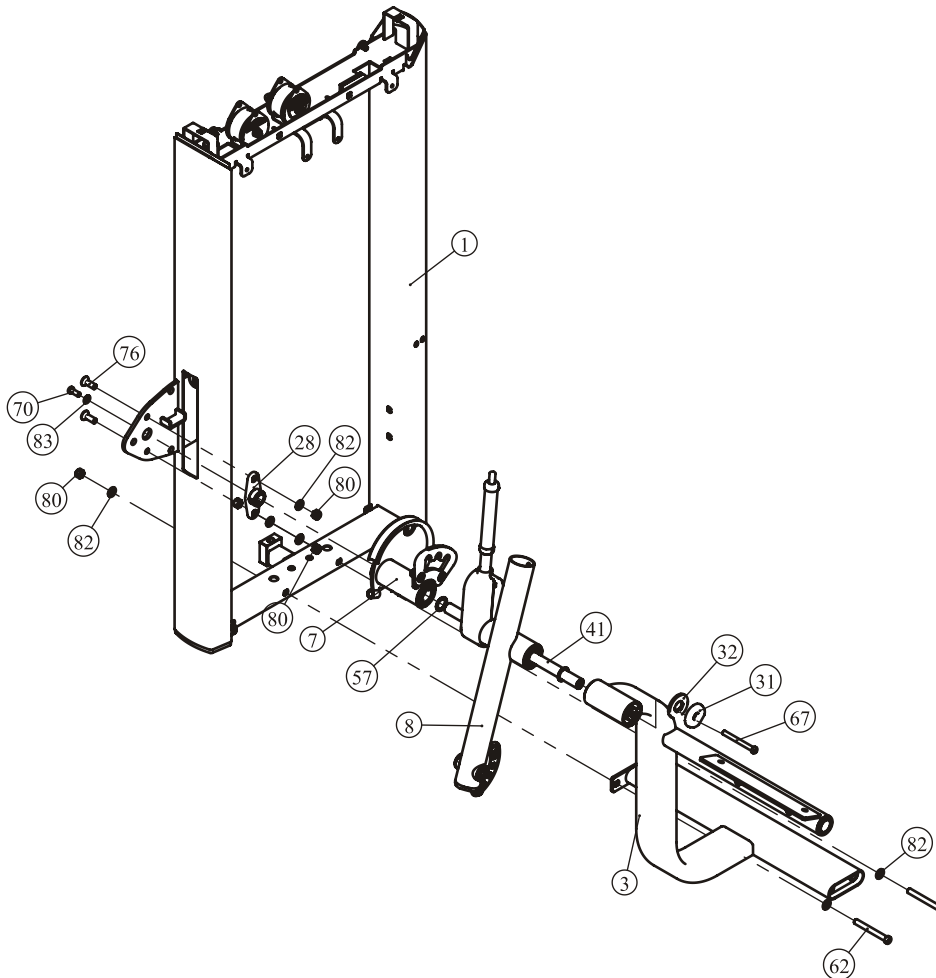

Assembly

STEP 2

1. Attach Main Frame ASSY (#2) and The Rear Cross Brace (#4) to The Weight Stack Frame ASSY (#1) and The Front Support Frame ASSY (#2) using:
 - two Plastic Cover I (#42)
 - four M12*180 SHCS (#62)
 - two M12*30 SHCS (#66)
 - one Plastic Cover II (#43)
 - two M12*120 SHCS (#63)
 - eight $\Phi 13 \times \Phi 24 \times 2.5$ Flat Washers (#82)
2. Attach The Counter Weight (#33) to The Swing Frame ASSY (#8) using:
 - two M8*25 SHCS (#71)
 - two $\Phi 8$ Spring Washer (#89)
 - two $\Phi 9 \times \Phi 16 \times 1.6$ Flat Washers (#84)
3. Attach The Foam Frame ASSY (#27) to The Swing Frame ASSY (#8) using:
 - two M10*25 Flat Head Cap Screw (#77)
 - one $\Phi 25.4 \times 92.5$ Shaft (#200)
 - two $\Phi 43 \times \Phi 10.5 \times 8$ Cap (#87)

Note: Wrench Tighten Bolts and Nylon Lock Nuts.

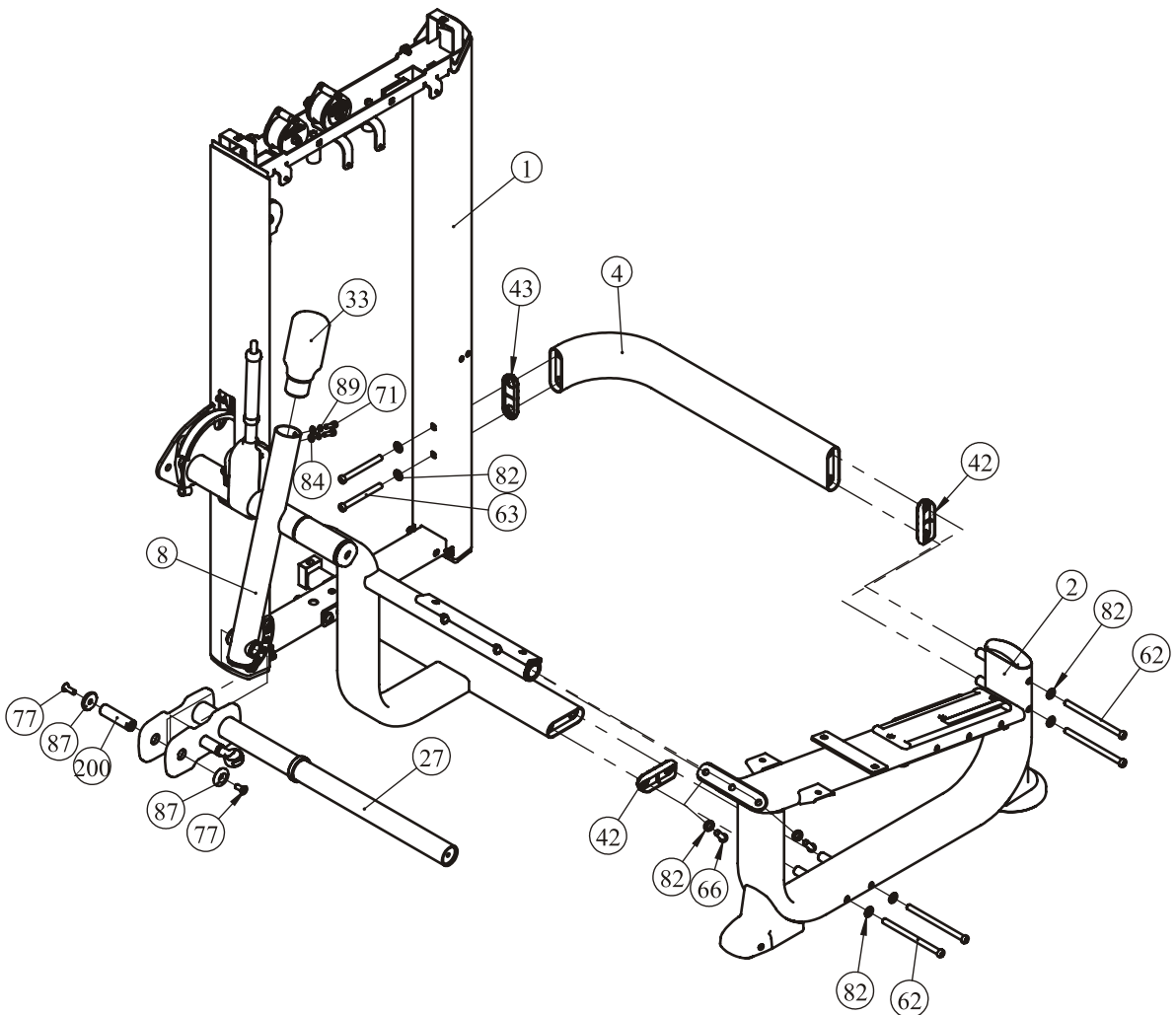

Assembly

STEP 3

1. Attach The Underside Support Plate (#30) to The Weight Stack Frame ASSY (#1) using:
two M8*25 BHCS (#72) two $\Phi 9*\Phi 16*1.6$ Flat Washers (#84)
2. Attach The Front Lower Cover (#17) to The Weight Stack Frame ASSY (#1) and The Underside Support Plate (#30) using:
two M6*20 BHCS (#74) two M6*12 BHCS (#100)
four $\Phi 6.6*\Phi 12*1.6$ Flat Washers (#85)

Note: Wrench Tighten Bolts and Nylon Lock Nuts.

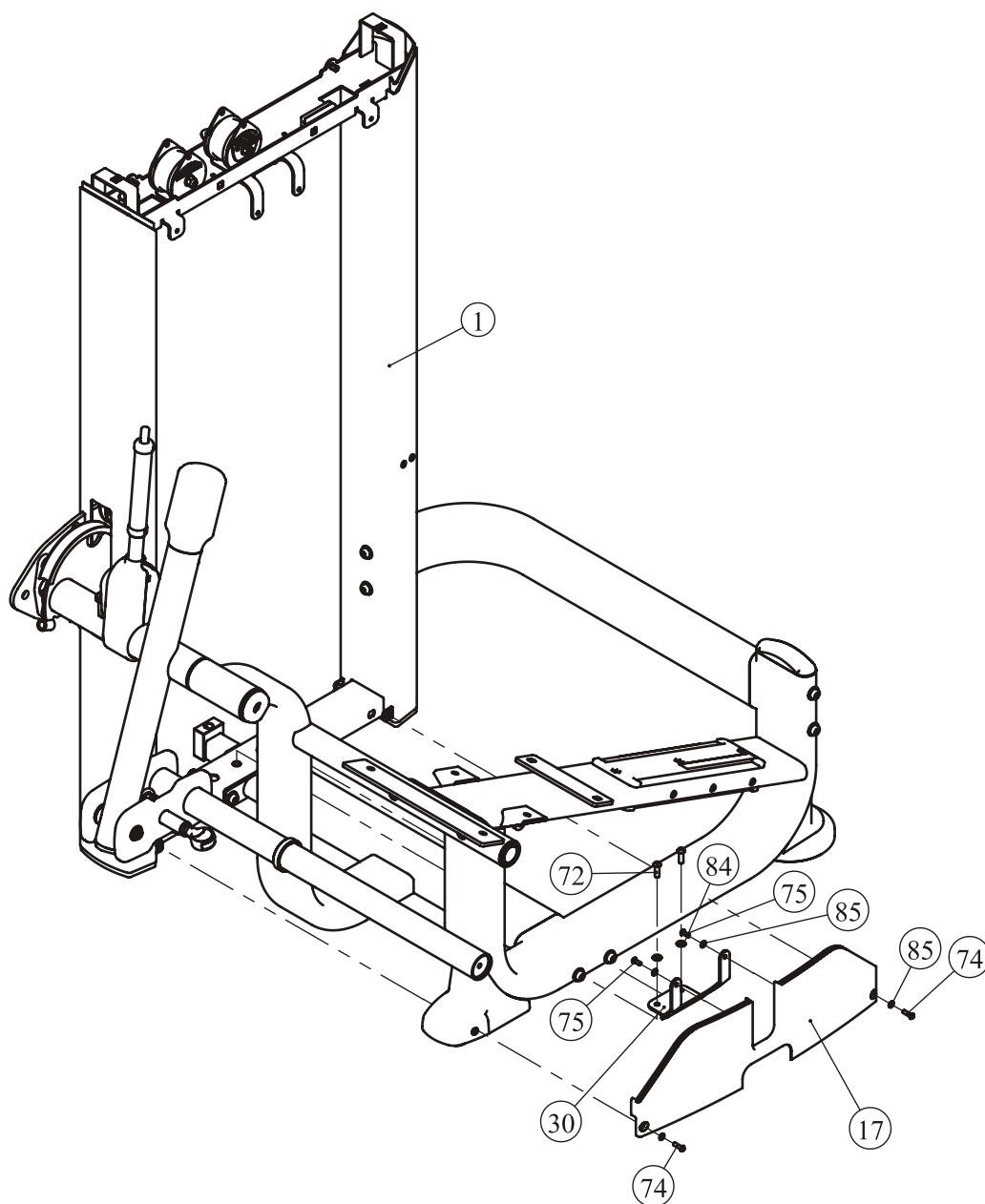

Assembly

STEP 4 Here is the assembly instruction for 15LBSx15PCS Weights !

1. Attach:

- | | |
|--|--|
| two $\Phi 19$ Guide Rods (#38) | two $\Phi 76*60$ Weight Rubber Bumpers (#52) |
| fifteen Weight Plate 15LBS (#119) | two Weight Stack Space (#120) |
| one Top Plate ASSY (#44) | |
| to The Weight Stack Frame ASSY (#1) using: | |
| two M8*45 SHCS (#65) | two $\Phi 9*\Phi 16*1.6$ Flat Washers (#84) |
| two $\Phi 30*65$ Rubber Sleeve (#34) | two $\Phi 8$ Spring Washers (#89) |
| two Tension Spring (#166) | |

2. Attach The Selector Pin W/Coil (#49) to The Top Plate ASSY (#44).

3. Loosen one M8*8 Screw (#78), and Attach:

- | | |
|--|---|
| one $\Phi 14*1296$ Guide Rod (#45) | one 5LBS Counter Weight (#55) |
| to The Weight Stack Frame ASSY (#1) using: | |
| one $\Phi 22*2*66$ Limiting tube (#46) | one $\Phi 15*\Phi 40*3$ Flat Washer (#53) |
| one $\Phi 14*\Phi 40*25.4$ Plug Bumper (#54) | one M10*25 SHCS (#70) |
| one $\Phi 10$ Spring Washer (#88) | one $\Phi 11*\Phi 20*2$ Flat Washer (#83) |

4. Wrench Tighten M8*8 Screw (#78).

Note: Wrench Tighten Bolts and Nylon Lock Nuts.

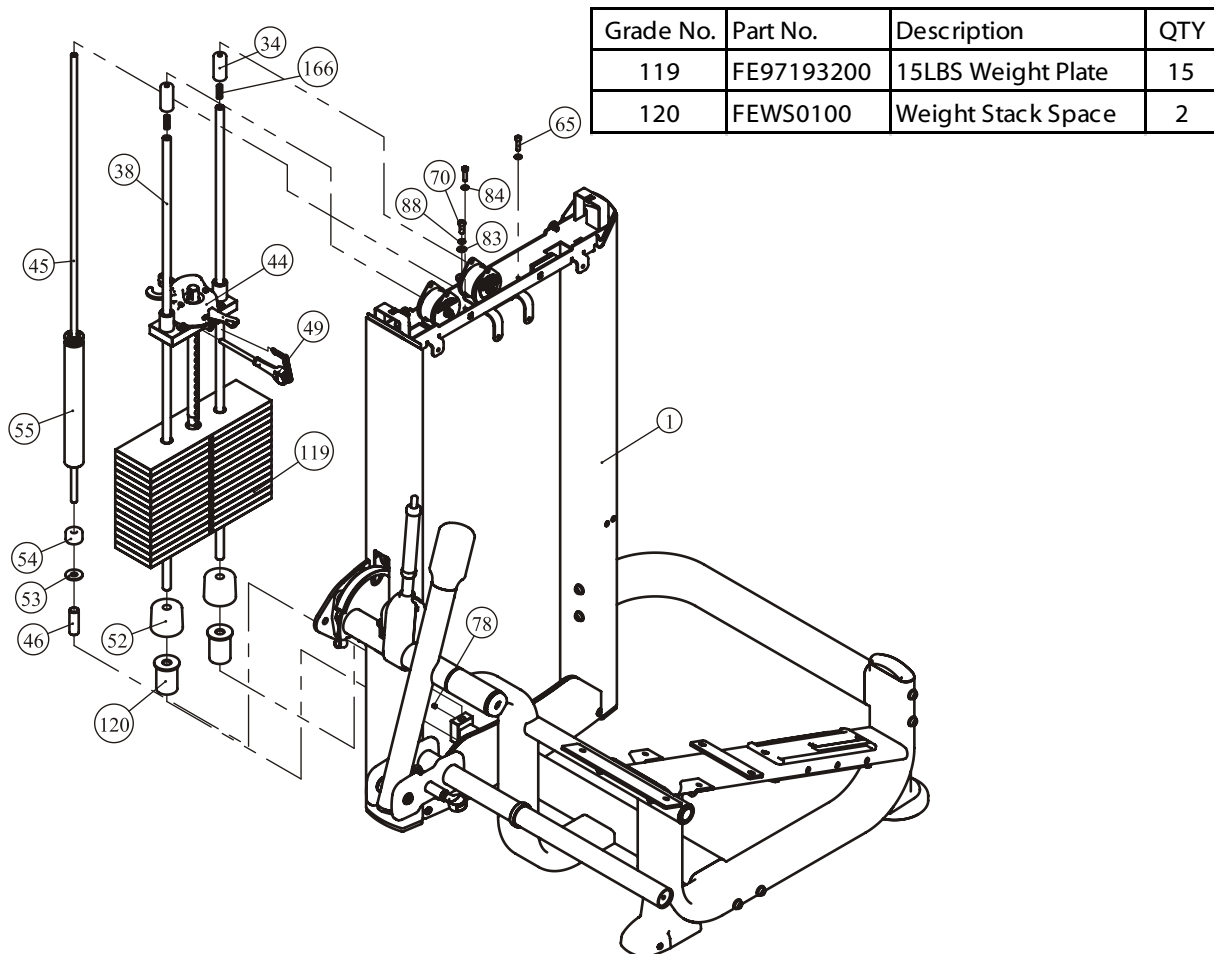

Assembly

STEP 4 Here is the assembly instruction for 15LBSx19PCS Weights !

1. Attach:

- | | |
|--|--|
| two $\Phi 19$ Guide Rods (#38) | two $\Phi 76*60$ Weight Rubber Bumpers (#52) |
| fifteen Weight Plate 15LBS (#119) | one Top Plate ASSY (#44) |
| to The Weight Stack Frame ASSY (#1) using: | |
| two M8*45 SHCS (#65) | two $\Phi 9*\Phi 16*1.6$ Flat Washers (#84) |
| two $\Phi 30*65$ Rubber Sleeve (#34) | two $\Phi 8$ Spring Washers (#89) |
| two Tension Spring (#166) | |

2. Attach The Selector Pin W/Coil (#49) to The Top Plate ASSY (#44).

3. Loosen one M8*8 Screw (#78), and Attach:

- | | |
|--|---|
| one $\Phi 14*1296$ Guide Rod (#45) | one 5LBS Counter Weight (#55) |
| to The Weight Stack Frame ASSY (#1) using: | |
| one $\Phi 22*2*66$ Limiting tube (#46) | one $\Phi 15*\Phi 40*3$ Flat Washer (#53) |
| one $\Phi 14*\Phi 40*25.4$ Plug Bumper (#54) | one M10*25 SHCS (#70) |
| one $\Phi 10$ Spring Washer (#88) | one $\Phi 11*\Phi 20*2$ Flat Washer (#83) |

4. Wrench Tighten M8*8 Screw (#78).

Note: Wrench Tighten Bolts and Nylon Lock Nuts.

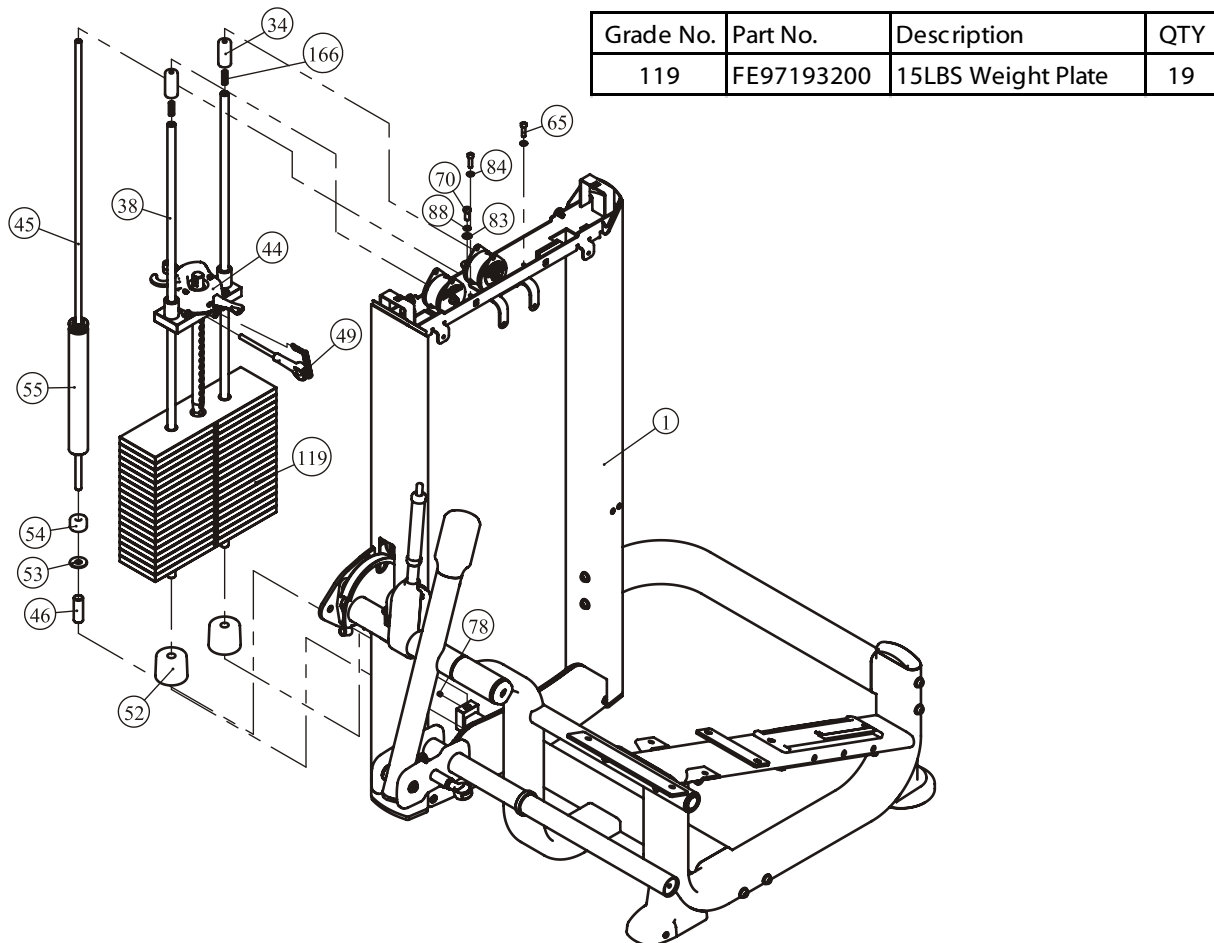

Assembly

Please assemble according to the actual **Weights** you buy !

10LBS×15PCS

10LBS×19PCS

Grade No.	Part No.	Description	QTY	Grade No.	Part No.	Description	QTY
1	FE971930ASSY	10LBS Top Plate ASSY	1	1	FE971930ASSY	10LBS Top Plate ASSY	1
2	FE97193100	10LBS Weight Plate	15	2	FE97193100	10LBS Weight Plate	19
3	IN-D10132900	Weight Rubber Bumpers	2	3	IN-D10132900	Weight Rubber Bumpers	2
4	FEWS01ASSY	Weight Stack Space	2				

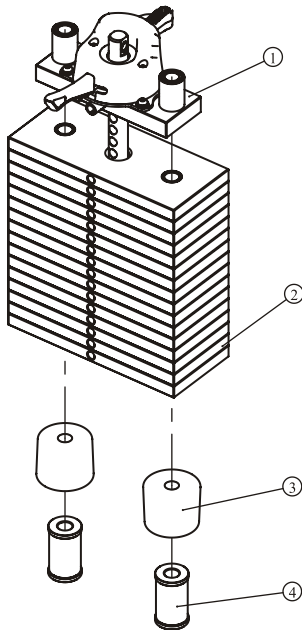

LBS 20	9	KGS
LBS 30	14	KGS
LBS 40	18	KGS
LBS 50	23	KGS
LBS 60	27	KGS
LBS 70	32	KGS
LBS 80	36	KGS
LBS 90	41	KGS
LBS 100	45	KGS
LBS 110	50	KGS
LBS 120	54	KGS
LBS 130	59	KGS
LBS 140	64	KGS
LBS 150	68	KGS
LBS 160	73	KGS
LBS 170	77	KGS
LBS 180	82	KGS
LBS 190	86	KGS
LBS 200	91	KGS
LBS 210	95	KGS
LBS 220	100	KGS
LBS 230	104	KGS

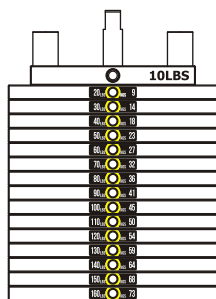
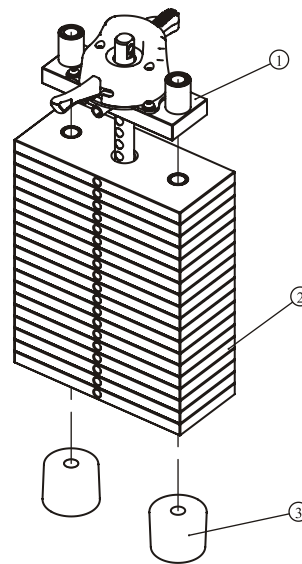

20-160LBS

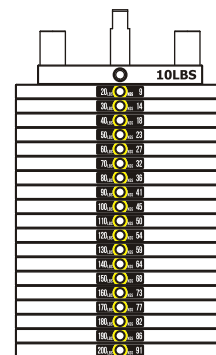

20-200LBS

Weight plate sticker paste schematic diagram

Assembly

Please assemble according to the actual **Weights** you buy !

15LBS×15PCS

15LBS×19PCS

Grade No.	Part No.	Description	QTY	Grade No.	Part No.	Description	QTY
1	FE971930ASSY	10LBS Top Plate ASSY	1	1	FE971930ASSY	10LBS Top Plate ASSY	1
2	FE97193200	15LBS Weight Plate	15	2	FE97193200	15LBS Weight Plate	19
3	IN-D10132900	Weight Rubber Bumpers	2	3	IN-D10132900	Weight Rubber Bumpers	2
4	FEWS01ASSY	Weight Stack Space	2				

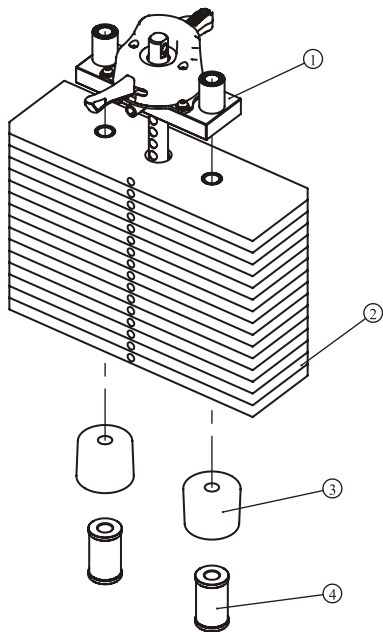

LBS 25	11	KGS
LBS 40	18	KGS
LBS 55	25	KGS
LBS 70	32	KGS
LBS 85	38	KGS
LBS 100	45	KGS
LBS 115	52	KGS
LBS 130	59	KGS
LBS 145	66	KGS
LBS 160	72	KGS
LBS 175	79	KGS
LBS 190	86	KGS
LBS 205	93	KGS
LBS 220	100	KGS
LBS 235	107	KGS
LBS 250	113	KGS
LBS 265	120	KGS
LBS 280	127	KGS
LBS 295	134	KGS
LBS 310	141	KGS
LBS 325	147	KGS

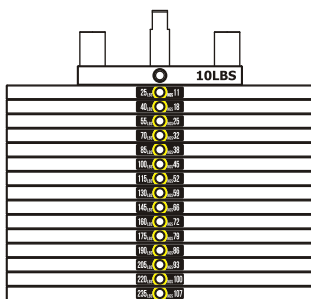
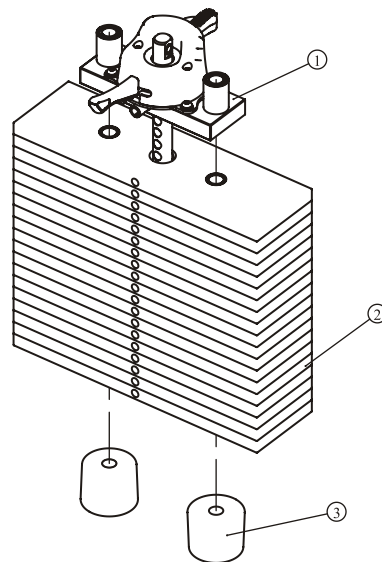

25-235LBS

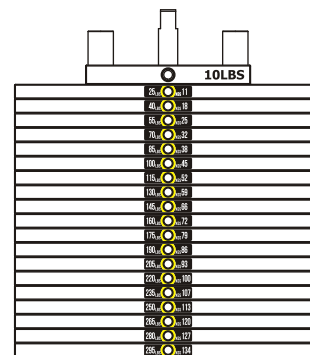

25-295LBS

Weight plate sticker paste schematic diagram

Assembly

Please assemble according to the actual **Weights** you buy !

10LBS×15PCS

10LBS×19PCS

Grade No.	Part No.	Description	QTY	Grade No.	Part No.	Description	QTY
1	FE970230ASSY	40LBS Top Plate ASSY	1	1	FE970230ASSY	40LBS Top Plate ASSY	1
2	FE97193100	10LBS Weight Plate	15	2	FE97193100	10LBS Weight Plate	19
3	IN-D10132900	Weight Rubber Bumpers	2	3	IN-D10132900	Weight Rubber Bumpers	2
4	FEWS01ASSY	Weight Stack Space	2				

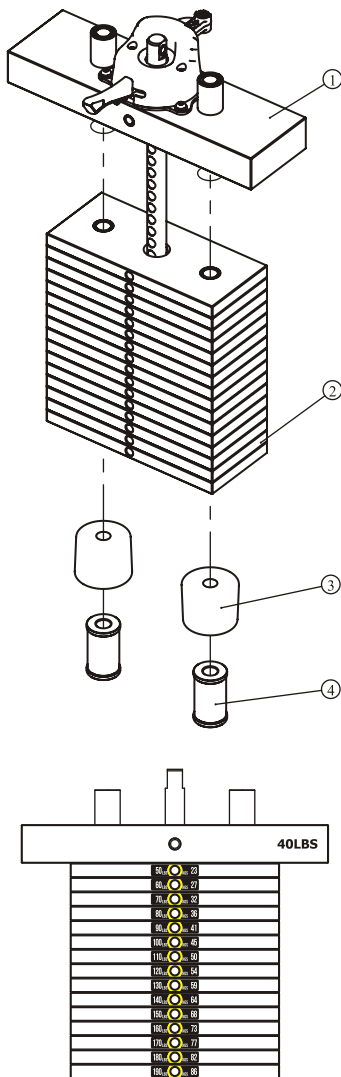

50-190LBS

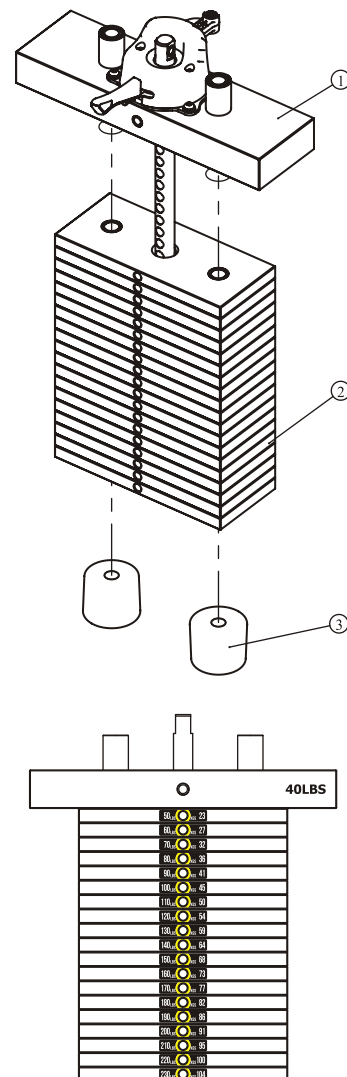

50-230LBS

Weight plate sticker paste schematic diagram

Note: 30LBS weight are used the function of balance.

Assembly

Please assemble according to the actual **Weights** you buy !

15LBS×15PCS

15LBS×19PCS

Grade No.	Part No.	Description	QTY	Grade No.	Part No.	Description	QTY
1	FE970230ASSY	40LBS Top Plate ASSY	1	1	FE970230ASSY	40LBS Top Plate ASSY	1
2	FE97193200	15LBS Weight Plate	15	2	FE97193200	15LBS Weight Plate	19
3	IN-D10132900	Weight Rubber Bumpers	2	3	IN-D10132900	Weight Rubber Bumpers	2
4	FEWS01ASSY	Weight Stack Space	2				

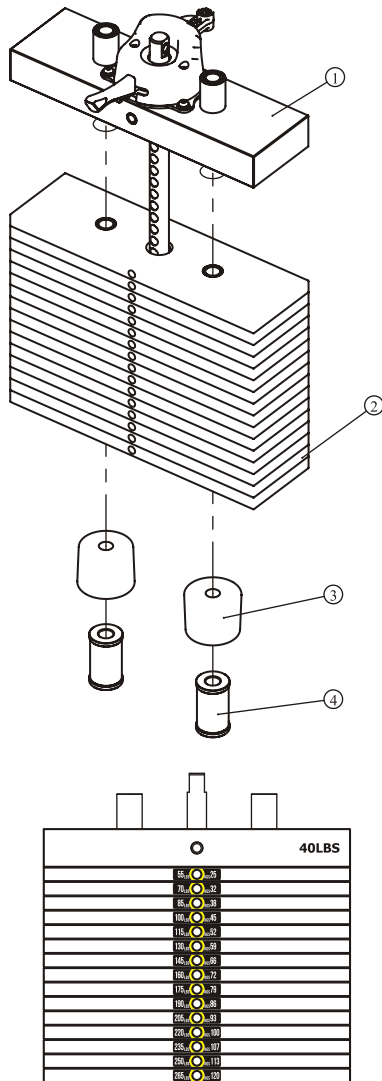

55-265LBS

LBS 25	11 KGS
LBS 40	18 KGS
LBS 55	25 KGS
LBS 70	32 KGS
LBS 85	38 KGS
LBS 100	45 KGS
LBS 115	52 KGS
LBS 130	59 KGS
LBS 145	66 KGS
LBS 160	72 KGS
LBS 175	79 KGS
LBS 190	86 KGS
LBS 205	93 KGS
LBS 220	100 KGS
LBS 235	107 KGS
LBS 250	113 KGS
LBS 265	120 KGS
LBS 280	127 KGS
LBS 295	134 KGS
LBS 310	141 KGS
LBS 325	147 KGS

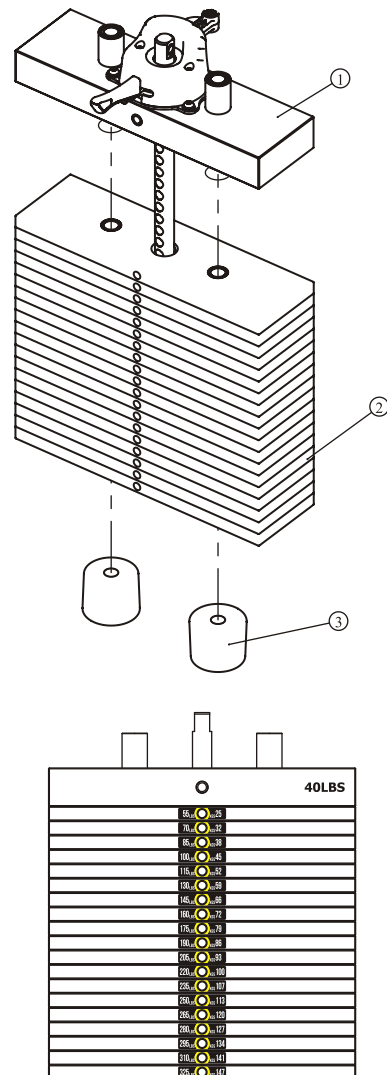

55-325LBS

Weight plate sticker paste schematic diagram

Note: 30LBS weight are used the function of balance.

Assembly

STEP 5

1. Attach one end of The Belt ASSY (#36) to The Weight Stack Frame ASSY (#1) using:
one $\Phi 13 \times \Phi 24 \times 2.5$ Flat Washer (#82) one M12 Nylon Lock Nut (#80)
2. Attach the other end of The Belt ASSY (#36) through The Bracket of Belt Pulley (#29), and assemble The $\Phi 76$ Narrow Belt Pulley (#35) to The Bracket of Belt Pulley (#29) using:
one M10*65 SHCS (#68) two $\Phi 11 \times \Phi 20 \times 2$ Flat Washers (#83)
one M10 Nylon Lock Nut (#81)
And through two Belt Pulleys on the Weight Stack Frame ASSY (#1).
3. Attach the other end of The Belt ASSY (#36) to the Top Plate ASSY (#44) using:
one M10*45 SHCS (#69) two $\Phi 11 \times \Phi 20 \times 2$ Flat Washers (#83)
one M10 Nylon Lock Nut (#81)
Attach two $\Phi 17 \times 49$ Belt Rubber Sleeves (#37) to The Weight Stack Frame ASSY (#1) using:
two $\Phi 13 \times \Phi 8 \times 65.5$ Spacer Pins (#40) two $\Phi 6$ Shaft Ring Opening (#92)
4. Attach The Cable (#20) to The Cam Frame ASSY (#7).
And attach the other end of The Cable (#20) through one 4.5" Pulley on the Weight Stack Frame ASSY (#1) to The Bracket of Belt Pulley (#29) using:
one M10*45 SHCS (#69) two $\Phi 11 \times \Phi 20 \times 2$ Flat Washers (#83)
one M10 Nylon Lock Nut (#81)

Note: Wrench Tighten Bolts and Nylon Lock Nuts.

STEP 6

1. Attach The Back Lower Cover (#19) to The Weight Stack Frame ASSY (#1) using:
three M6*20 BHCS (#74) three $\Phi 6.6 \times \Phi 12 \times 1.6$ Flat Washers (#85)
2. Attach two Front Shroud (#15) to The Front Lower Cover (#17) on The Weight Stack Frame ASSY (#1).
3. Assemble The Console PCB, and attach The Training Placard Cover ASSY (#16) to The Weight Stack Frame ASSY (#1) using:
four M6*15 BHCS (#75) four $\Phi 6.6 \times \Phi 12 \times 1.6$ Flat Washers (#85)
4. Attach The Back Shroud (#18) to The Back Lower Cover (#19) and The Weight Stack Frame ASSY (#1) using:
two M6*20 BHCS (#74) two $\Phi 6.6 \times \Phi 12 \times 1.6$ Flat Washers (#85)
5. Attach The Top Cover (#47) to The Weight Stack Frame ASSY (#1) using:
two M6*20 BHCS (#74) two $\Phi 6.6 \times \Phi 12 \times 1.6$ Flat Washers (#85)
6. Attach The Back CAM Cover (#58) to The Weight Stack Frame ASSY (#1) using:
three M6*12 BHCS (#100) three $\Phi 6.6 \times \Phi 23 \times 2$ Flat Washers (#86)
7. Attach the Front CAM Cover (#22) to The Cam Frame ASSY (#7), and Attach The Accessory Plastic Plate (#23) to The Front CAM Cover (#22).
Attach the Front CAM Cover (#22) and The Accessory Plastic Plate (#23) to The Back CAM Cover (#21) using:
two M6*20 BHCS (#74) two $\Phi 6.6 \times \Phi 12 \times 1.6$ Flat Washers (#85)

Note: Wrench Tighten Bolts.

Assembly

STEP 5

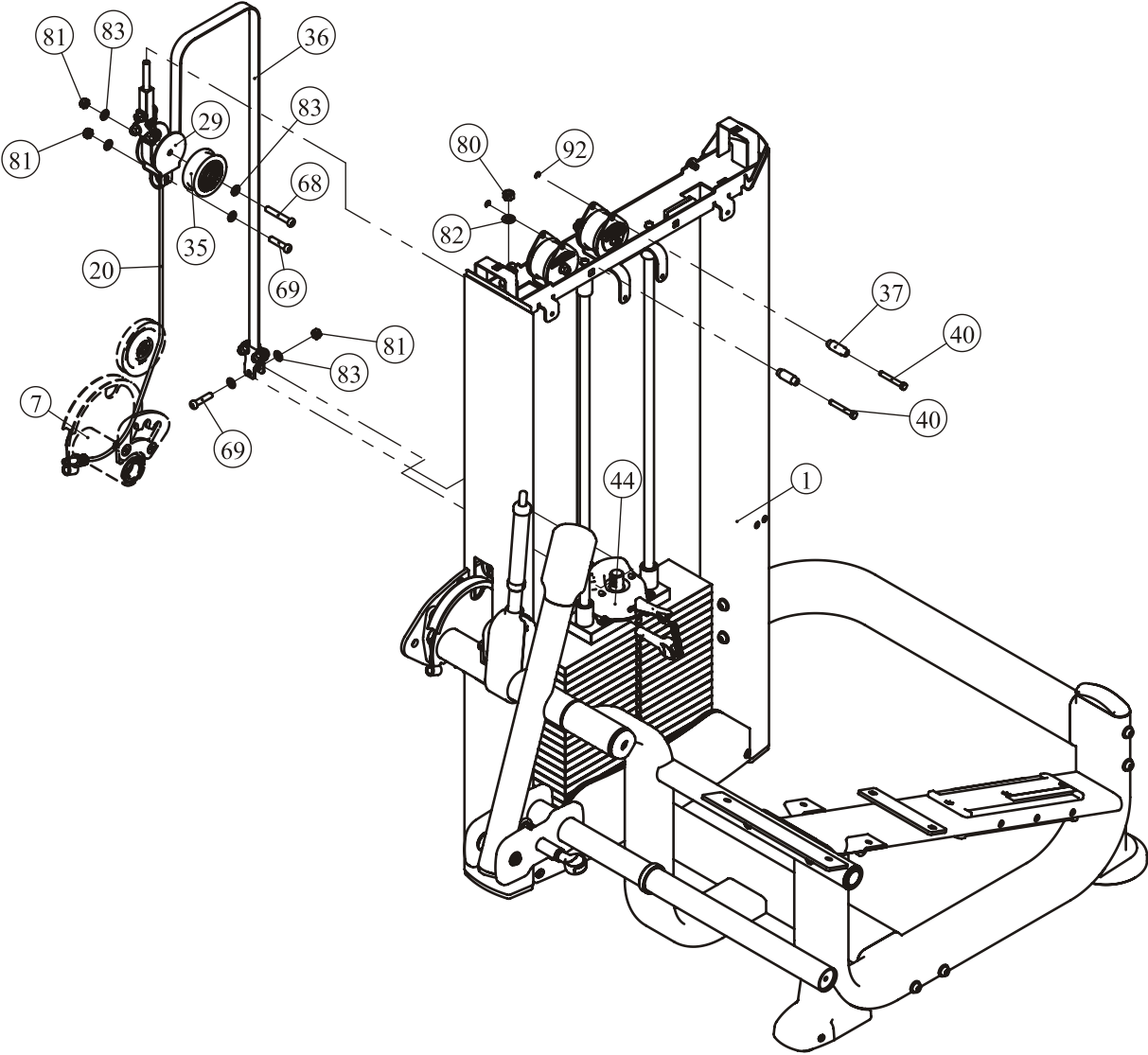

Assembly

STEP 6

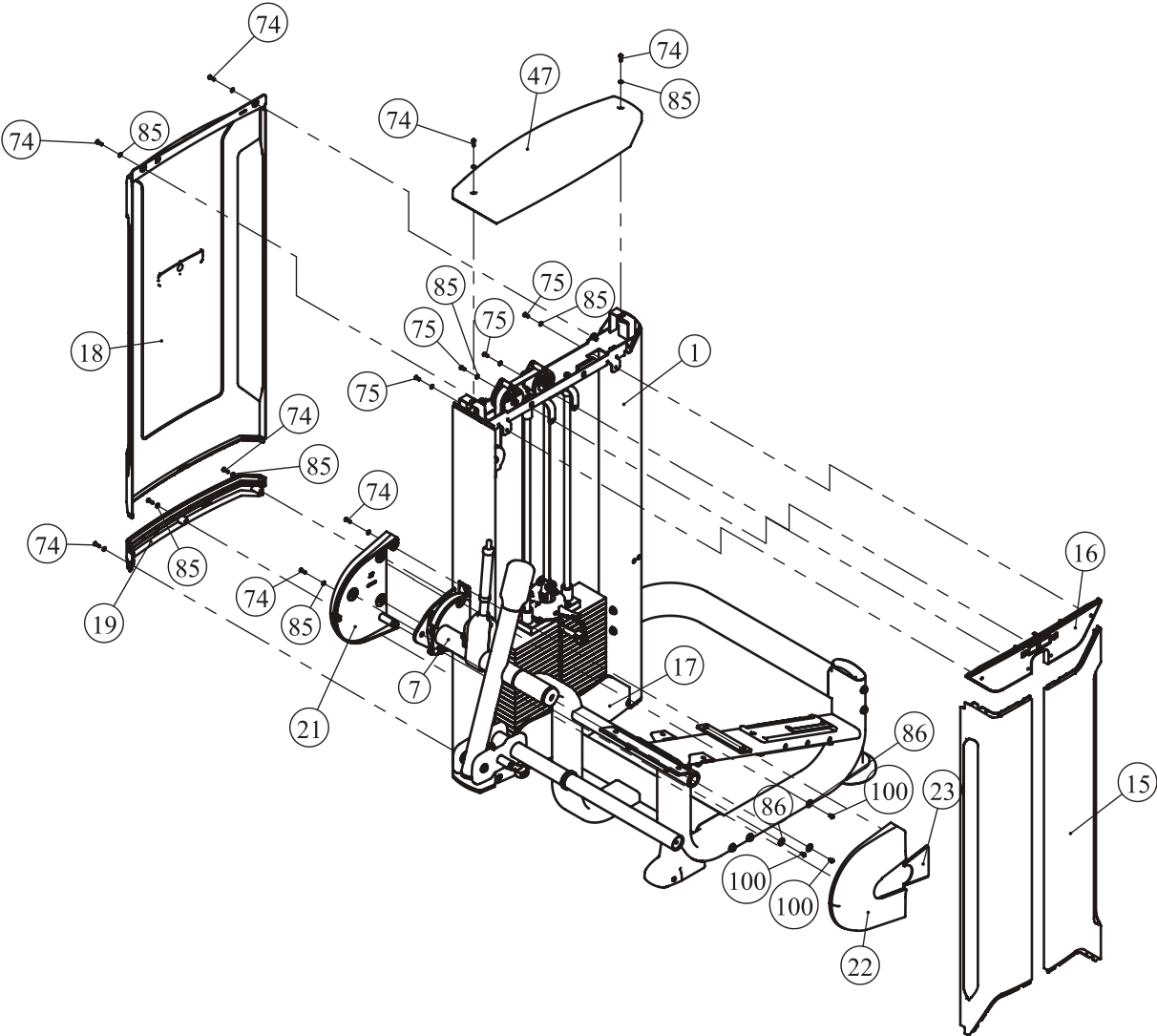
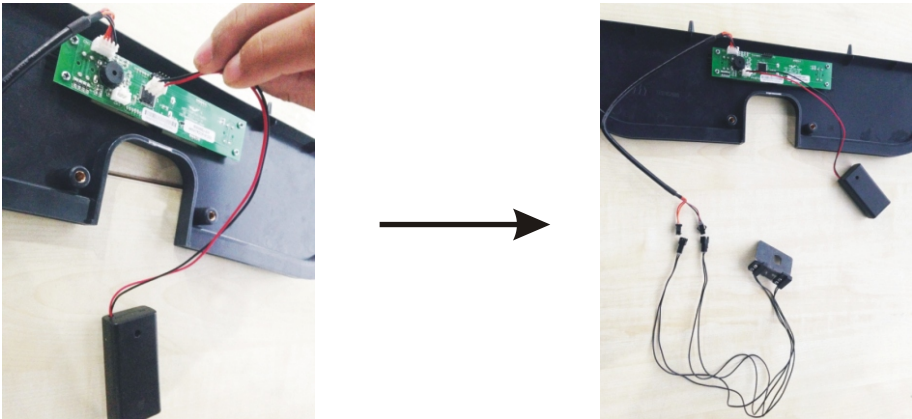

Assembly

STEP 7

1. Attach eight M6*8 Screw (#79) to four $\Phi 34*19*36.6$ Adjustment Sleeve (#10).
 2. Attach The Plastic End Cap (#26) to The Cup Holder (#24).
Attach The Plastic End Cap (#26) and The Cup Holder (#24) to The Bracket of Cup Holder (#25) using:
two M6*15 BHCS (#75)
Attach the Assemble good parts (#24/#25/#26) to The Weight Stack Frame ASSY (#1) using:
two M6*20 BHCS (#74) two $\Phi 6.6*\Phi 12*1.6$ Flat Washers (#85)
two $\Phi 6$ Spring Washer (#90)
 3. Attach The Back Pad Frame ASSY (#5) and two Roller ASSY (#51) to The Roller Press of The Main Frame ASSY (#2) using:
two $\Phi 17*177$ Long Threaded Shaft (#12) four $\Phi 34*\Phi 19*36.6$ Adjustment Sleeve (#10)
four $\Phi 34*5$ Small End Cover $\Phi 34*5$ (#58) four M10*25 SHCS (#70)
 4. Attach The Tension Spring (#11) to The Main Frame ASSY (#2) and The Back Pad Frame ASSY (#5) using:
two M8*15 BHCS (#73) two $\Phi 9*\Phi 16*1.6$ Flat Washers (#84)
one $\Phi 14*149$ Spring Shaft (#9)
- Note: Adjust the Screw (#79) to smooth the Roller.**
5. Attach The Double Handle Frame ASSY (#6) to The Back Pad Frame ASSY (#5) using:
two M10*45 SHCS (#69) two $\Phi 10$ Spring Washer (#88)

Note: Wrench Tighten Bolts and Nylon Lock Nuts.

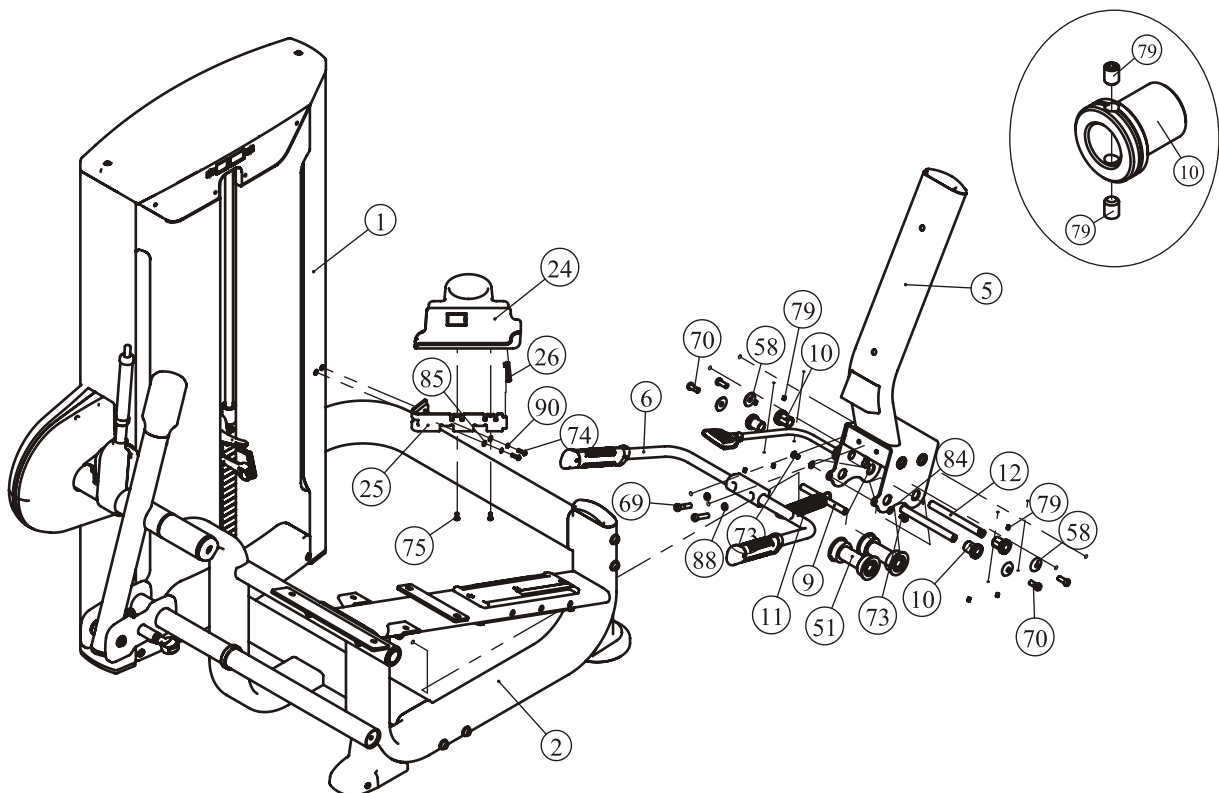

Assembly

STEP 8

1. Attach The Front Seat Pad (#13) to The Main Frame ASSY (#2) using:
two M10*25 SHCS (#70) two $\Phi 11*\Phi 20*2$ Flat Washers (#83)
2. Attach The Seat Pad Support Plate (#56) to The Main Frame ASSY (#2) using:
two M10*25 FHCS (#77) two $\Phi 11*\Phi 20*2$ Flat Washers (#83)
two M10 Nylon Lock Nuts (#81)
3. Attach The Wide Seat Pad (#14) to The Main Frame ASSY (#2) and The Seat Pad Support Plate (#56) using:
four M10*25 SHCS (#70) four $\Phi 11*\Phi 20*2$ Flat Washers (#83)
4. Attach The Back Pad ASSY (#48) to The Back Pad Frame ASSY (#5) using:
two M10*65 SHCS (#68) two $\Phi 11*\Phi 20*2$ Flat Washers (#83)
5. Attach The Leather Wrapped Round Foam (#50) to The Foam Frame ASSY (#27) using:
one $\Phi 60$ Cap (#31) one M10*25 SHCS (#70)

Note: Wrench Tighten Bolts and Nylon Lock Nuts.

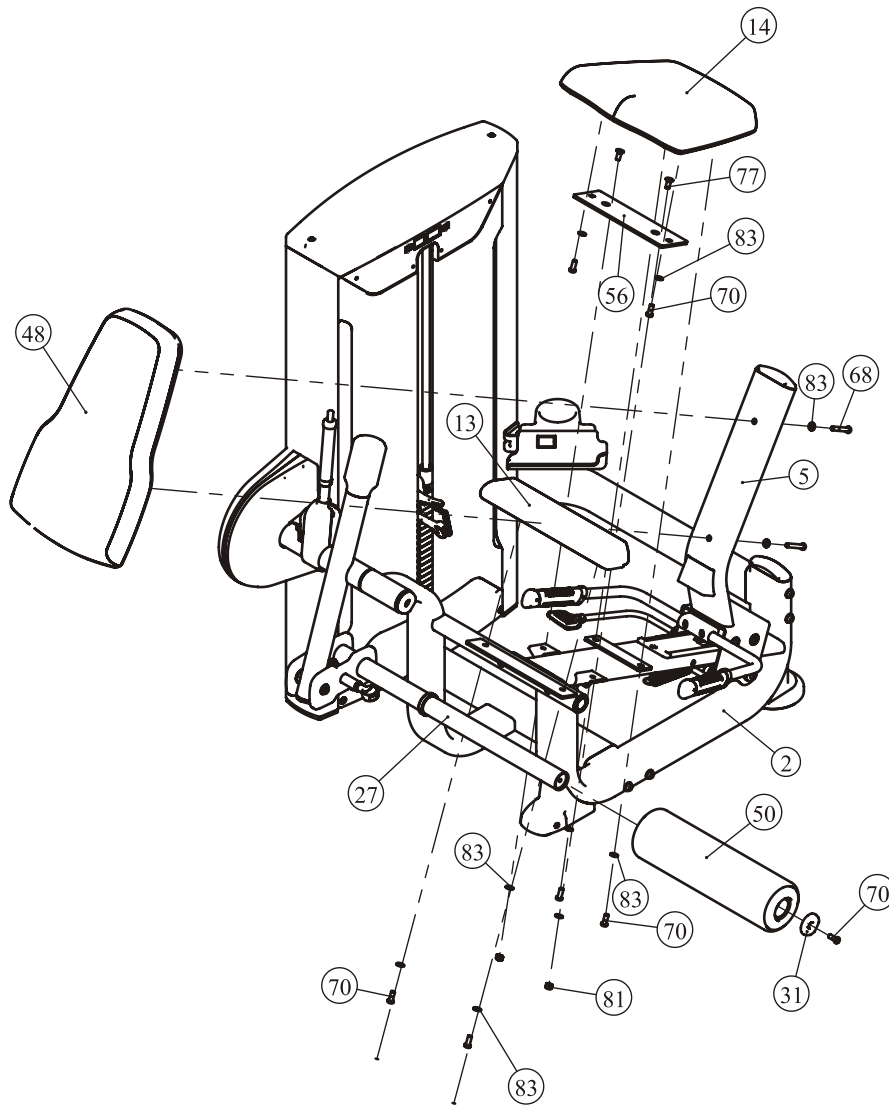

Adjust Instructions

The use of Selector Pin W/Coil

1. Select an appropriate weight and put the Selector Pin W/Coil into the hole on it.
2. Make sure the Selector Pin W/Coil gets into the hole completely.

The Cam adjustment

1. Pull out the pin and adjust the Foam Frame ASSY to the desired position.
2. Make sure the pin get into the hole completely.

The 5LBS Counter Weight adjustment

1. Toggle the Shifting Fork to the desired position.
2. Make sure the Shifting Fork get into the Fillister completely.

The Fanshaped Adjustment Plate adjustment

1. Press the Press Button, and adjust the Swing Frame ASSY to the desired position.
2. Make sure the pin get into the hole completely.

The Back Pad adjustment

1. Lift the Regulation Handle, and adjust the Back Pad to the desired position.
2. Make sure the pin get into the hole completely.

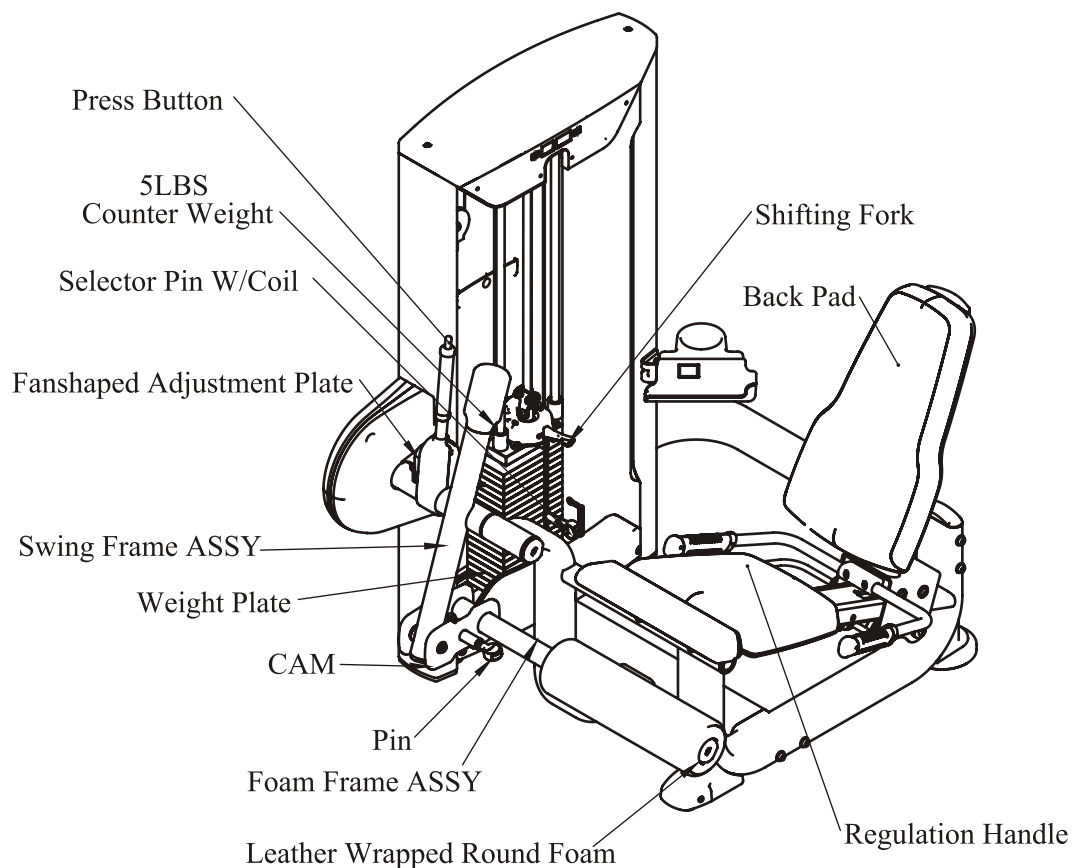

Exercise Instructions

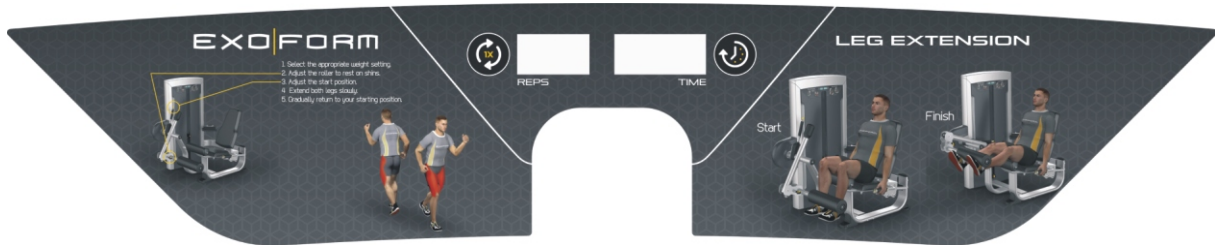

1. Select the appropriate weight setting.
2. Adjust the roller to rest on shins.
3. Adjust the start position.
4. Extend both legs slowly.
5. Gradually return to your starting position.



Start



Finish



Console Panel Function



1. CONSOLE PANEL FUNCTION

1.1 TIME WINDOW

Indicates elapsed time after pressing start in minutes and seconds (0-99minutes, 0-59seconds).

1.2 REPS WINDOW

Indicates times of workout cycle (0-999).

2. BUTTONS

2.1 REPS RESET: Reset value of REPS window.

2.2 TIME RESET: Reset value of TIME window

3. SAVE POWER MODE

3.1 Switched on automatically when there is signal input.

3.2 The screen turn off of self after 3 minutes in stop station.

Battery Replacement

Battery replacement

For this computer you need 2 pcs. 1.5V AA batteries. If the display quality gets poor, you should replace the battery. Therefore please open the battery case cover on the back side of your computer and replace the old battery by a fitting new one. Close the case cover properly.



You must check the batteries regularly to prevent leakage from damaging console.

Battery-Disposal

Batteries should not be considered as regular garbage. As consumer you are obliged to return finished batteries. The finished batteries can be returned to a collection base at your residential area or at places, where batteries can be bought.



WE RECOMMEND THE USE OF ALCALI-MANGAN BATTERIES.

You will find these symbols on batteries, which contain harmful substances:

Pb = Battery contains lead

Cd = Battery contains cadmium

Hg = Battery contains mercury



Pb



Cd



Hg

Maintenance Schedule

ROUTINE	COMMERCIAL MAINTENANCE	HOME MAINTENANCE	LATEST DATE ENTRY						
Inspect; Links, Pull Pins, Snap Locks, Swivels, Weight Stack Pins	DAILY	WEEKLY							
Clean; Upholstery	DAILY	WEEKLY							
Inspect; Cables or Belts and their tension	DAILY	WEEKLY							
Inspect; Accessory Bars, and Handles	WEEKLY	3 MONTHS							
Inspect; All Decals	WEEKLY	3 MONTHS							
Inspect; All Nuts and Bolts, Tighten if needed	WEEKLY	3 MONTHS							
Inspect; Anti-Skid Surface	WEEKLY	3 MONTHS							
Clean & Lubricate; Guide Rods with a Teflon (PTFE) based lubricant (Superlube)	MONTHLY	3 MONTHS							
Lubricate; Seat Sleeves, Turcite Bushings, Linear Bearing	MONTHLY	3 MONTHS							
Clean and Wax; All Glossy Finishes	6 MONTHS	YEARLY							
Repack with Grease; Linear Bearings	6 MONTHS	YEARLY							
Replace; Cables, Belts and Connecting Parts	YEARLY	3 YEARS							

Your equipment comes with a commercial maintenance decal. For personal, in home use, please follow the home maintenance schedule listed above.

General Maintenance Information

Links, Pull-Pins, Snap Hooks, Swivels, Weight Stack Pins:

- * Check all pieces for signs of visible wear or damage.
- * Check springs in snap hooks and pull-pins for proper tension and alignment.
- * If the spring sticks or has lost its rigidity, replace it immediately.

Upholstery:

- * To ensure prolonged upholstery life and proper hygiene, all upholstered pads should be wiped down with a damp cloth after every workout.
- * Periodically take the time to use a mild soap or an approved vinyl upholstery cleaner to deter the onset of cracking or drying. Avoid using any abrasive cleaners or cleaners not intended for use on vinyl.
- * Replace ripped or worn upholstery immediately.
- * Keep sharp or pointed objects clear of all upholstery.

Decals:

- * Inspect and familiarize yourself with any safety warnings or other user information posted on each decal.

Nuts and Bolts:

- * Inspect all nuts and bolts for any loosening and tighten if needed.
- * Go through a re-tightening sequence periodically to ensure that all hardware is tensioned proper.

Anti-Skid Surfaces:

- * These surfaces are designed to supply secure footing and need to be replaced if they appear worn or become slippery.

Belts and Cables:

- * We use only high quality belt, and mil-spec cables.
- * Visually inspect the belts and cables for fraying, cracking, peeling or discoloration.
- * While the machine is not in use, carefully run your fingers along the belt or cable to feel for thinning or bulging areas.
- * Replace belts and cables immediately at the first signs of damage or wear. Do not use equipment until belts or cables have been replaced.

Belt and Cable Tension:

- * Referring to the Owners Manual, when belts or cables are used check all bolts attachments to be sure they are properly attached.
- * Check slack in cables and re-adjust cable tension if needed.

Seat Sleeves, Guide Rods:

- * Wipe down adjusting tubes with a dust free rag before applying lubricant.
- * Lubricate seat sleeves and Guide Rods with a Silicon or Teflon based lubricant spray.

Linear Bearings:

- * Referring to the Owners Manual carefully disassemble the bearing from its housing and place a finger full of light grease (lithium, super lube, etc.) into the inside of the bearing. Using your finger, press the grease into the ball-bearings and their tracks. Repeat until the ball-bearing tracks are full of grease. Insert the shaft back into the bearing and wipe off excess grease.

PLEASE KEEP THIS FOR YOUR RECORDS

Weight Training Tips

Use this manual to guide you through the basic exercises you can perform on your equipment. To gain maximum results and avoid possible injury, consult a fitness professional to develop your complete exercise program.

Always consult your physician before starting any exercise program.

To be successful in your exercise program, it is important to develop an understanding of the basic principles of strength training. Now that you have your equipment, it is only natural that you want to get started immediately. First, determine a set of realistic goals and objectives for yourself. By deciding on an exercise plan that is right for you prior to starting, you will contribute significantly to your success.

Warm up properly before engaging in weight resistance training. Stretching, yoga, jogging, calisthenics or other cardiovascular exercise can help prepare your body for the heavier workload of lifting weights.

Learn how to perform the exercise correctly before using heavy weight. Correct form is important to avoid injury and to ensure that you work the proper muscle groups.

Know your limitations. If you are new to weight training or are embarking on an exercise regimen after a long layoff, start slowly and build foundational strength over a longer period of time.

Pay attention to your breathing. Exhale when you exert is a general rule of thumb. Never hold your breath.

