

# FE9718

## TORSO ROTATION

### OWNER'S MANUAL

---

Rev A1 17ZV2

---

**CAUTION!** Read all precautions and instructions in this manual before using this equipment.

# Table Of Contents

## CAUTION!

Read all precautions and instructions in this manual before using this equipment.

Important Safety Instructions-----	3
Instructions-----	5
Exploded View and Parts List-----	6
Measurement Guide-----	26
Assembly Instructions-----	27
Assembly-----	28
Adjust Instructions-----	41
Exercise Instructions-----	42
Console Panel Function-----	42
Battery Replacement-----	43
Maintenance Schedule-----	44
General Maintenance Information-----	45
Weight Training Tips-----	46

Please assemble according to the actual **Weights** you buy !

# Important Safety Instructions

Before beginning any fitness program, you should obtain a complete physical examination from your physician. When using exercise equipment, basic precautions should always be taken, including the following:

1. Read all instructions before using the equipment.  
These instructions are written to ensure your safety and to protect the unit.
2. Use the equipment only for its intended purpose as described in this guide.  
Do not use accessory attachments that are not recommended by the manufacturer: such attachments might cause injuries.
3. The product should only be used on a level surface and is with 0.5 meters space around the product.  
Do not use the equipment outdoors.
4. Do not allow children on or near the equipment. And children are not allowed to use this equipment.  
Teenagers should use this equipment with adult supervision.
5. Do not overexert yourself or work to exhaustion.  
Do not attempt to lift more weight than you can control safely.  
If you feel any pain or abnormal symptoms, stop your workout immediately and consult your physician.
6. This equipment is not used as medical apparatus and instruments.
7. Never operate the unit when it has been dropped or damaged.  
Never drop or insert anything into any opening in the equipment.  
Always check the unit and its cables before each use. Make sure that all fasteners and cables are secure and in good working condition.  
Frayed or worn cables can be dangerous and may cause injury. Periodically check these cables for any indication of wear.  
Keep hands, limbs, loose clothing and long hair well out of the way of moving parts.
8. Be careful when getting on or off the equipment.
9. Wear proper exercise clothing and shoes for your workout, no loose clothing.

# Important Safety Instructions

## Personal Safety During Assembly

Read each step in the assembly instructions and follow the steps in sequence. Do not skip ahead. If you skip ahead, you may learn later that you have to disassemble components and that you may have damaged the equipment.

Assemble and operate the equipment on a solid, level surface. Locate the unit a few feet from walls or furniture to provide easy access. The equipment is designed for your enjoyment. By following these precautions and using common sense, you will have many safe and pleasurable hours of healthful exercise with the equipment.

## Training Area and Free Area

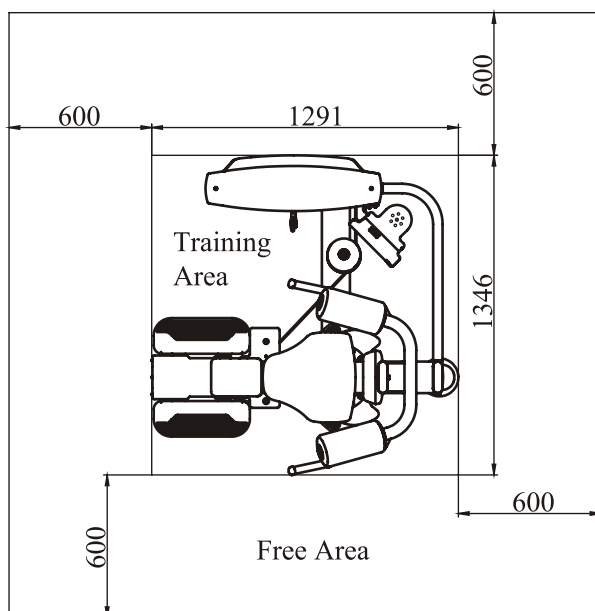

## Specifications

Class: S

Maximum Wt. Capacity: 134kg/ 295lbs

Maximum User Weight: 150kg/ 330lbs

Product Total Surface: 1291\*1346mm

Product Total Mass:

# Instructions

Before beginning assembly please take the time to read instructions thoroughly. Please use the various lists in this manual to make sure that all parts have been included in your shipment. When ordering, use part number and description from the lists. Use only our replacement part when servicing. Failure to do so will void your warranty and could result in personal injury.

The equipment is designed to provide the smoothest, most effective exercise motion possible. After assembly, you should check all functions to ensure correct operation. If you experience problems, first recheck the assembly instructions to locate any possible errors made during assembly. If you are unable to correct the problem, call your authorized dealer. Be sure to have your serial number and this manual when calling. When all parts have been accounted for, continue on.

## Tools Required



Ratchet Wrench and Socket



Adjustable Wrench



Rubber Mallet

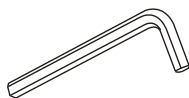

Hex Key Wrench Set



Phillips Screwdriver

# Exploded View and Parts List

## Weight Stack Frame Assy

Item No.	Grade No.	Part No.	Description	QTY
1	1.1	FE97180100	Weight Stack Frame	1
2	1.2	FE97211200	Top clamping plate	1
3	1.3	FE97122000	Plate for Sensor	1
4	1.4	FE97123000	Cover for Magnetic Iron	1
5	1.5	FE97011500	Foot Plate	2
6	1.6	FE97123900	Belt Pulley $\Phi 76$	2
7	1.7	IE951814700	Magnetic Iron	4
8	1.8	DQCGQ01	Sensor	2
9	1.9	DQDCH02	Cell Box	1
10	1.10	SMJ20*1*1000	Double faced adhesive tape	0.1
11	1.11	SG500110400V2	4.5" Pulleys	1
12	1.12	GB17880.5M8*16.5DCS17	Rivet Nut M8	4
13	1.13	GB17880.5M6*16.5DS17	Rivet Nut M6	4
14	1.14	NM10DN2	Nylon Lock Nut M10	3
15	1.15	GB9510DN2	Flat Washer $\Phi 11*\Phi 20*2$	6
16	1.16	GB956DN2	Flat Washer $\Phi 6.6*\Phi 12*1.6$	4
17	1.17	GB936N19	Spring Washer $\Phi 6$	4
18	1.18	AC32705800	U-nut M6	6
19	1.19	GB70BTM10*75DN18	Socket Head Cap Screw M10*75	2
20	1.20	GB70BTM10*50DN18	Socket Head Cap Screw M10*50	1
21	1.21	GB846ST2.9*9.5DS	Screw ST2.9*9.5	4
22	1.22	GB818M3*8DS2	Screw M3*8	4
23	1.23	PNLM6*12DN20	Button Head Cap Screw M6*12	4
24	1.24	PNLM8*25DN20NL	Button Head Cap Screw M8*25	2
25	1.25	YDMJ12*2*30	Hard Single-sided Adhesive Tape	6

# Exploded View and Parts List

## Weight Stack Frame Assy

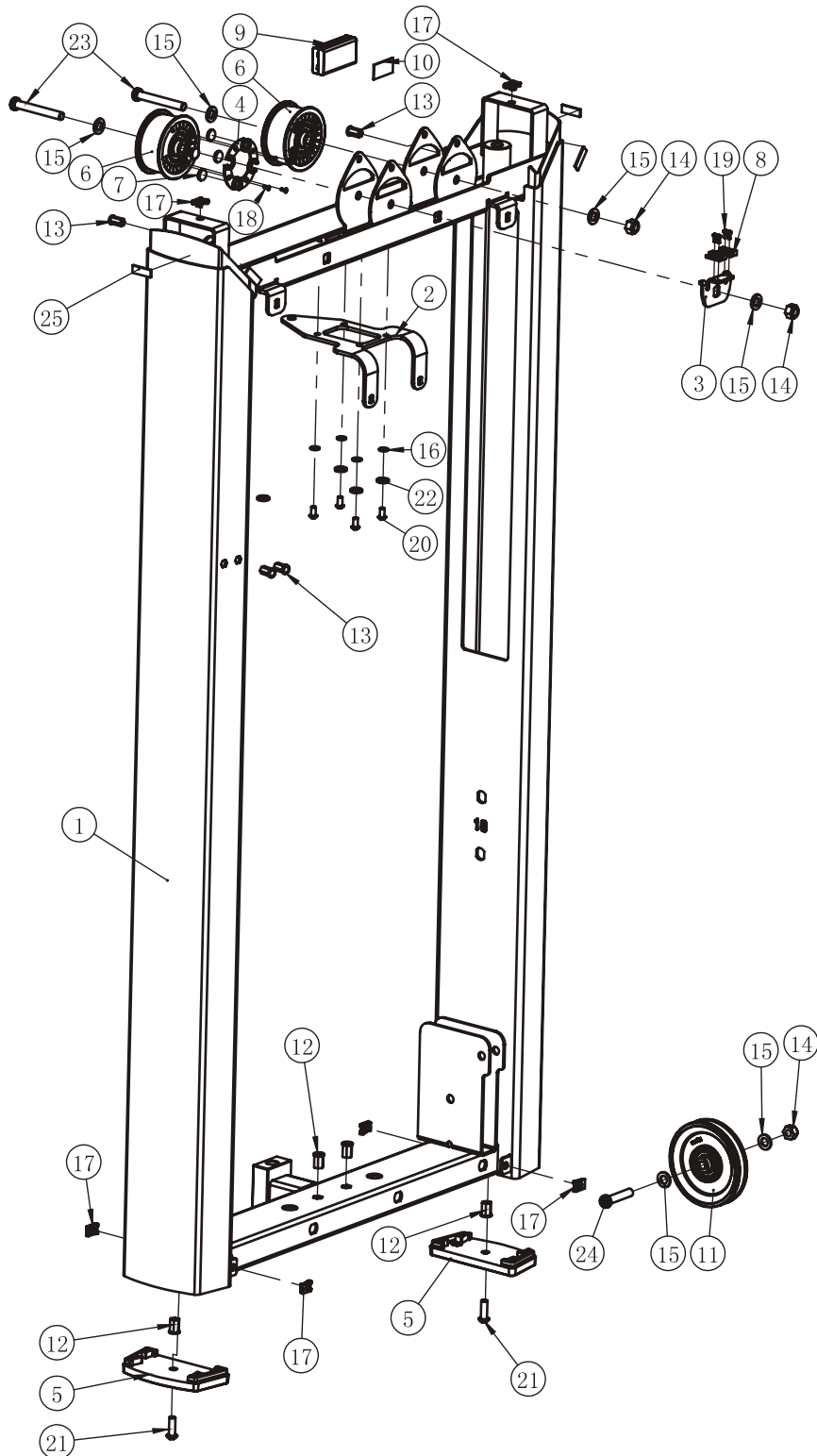

# Exploded View and Parts List

## Main Frame ASSY

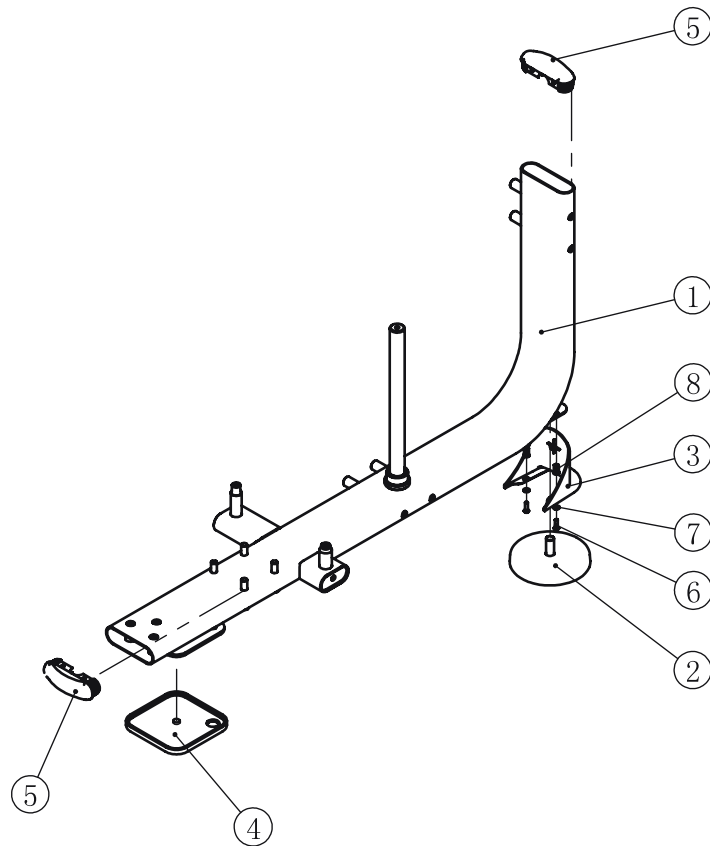

Item No.	Grade No.	Part No.	Description	QTY
1	2.1	FE97180200	Main Frame	1
2	2.2	SD1000B3000ASSY	Adjustable Foot Plate	1
3	2.3	FE97211700ASSY	Rear Ground Plastic Cover ASSY	1
4	2.4	CWRVL0051200	Foot Plate	1
5	2.5	FE97211500	Plug RT40*133*3	2
6	2.6	PNLM6*20DN20	Button Head Cap Screw M6*20	2
7	2.7	GB956DN2	Flat Washer $\Phi 6.6 * \Phi 12 * 1.6$	2
8	2.8	GB17880.5M6*16.5DS17	Rivet Nut M6	2



# Exploded View and Parts List

## Wriggled Frame ASSY

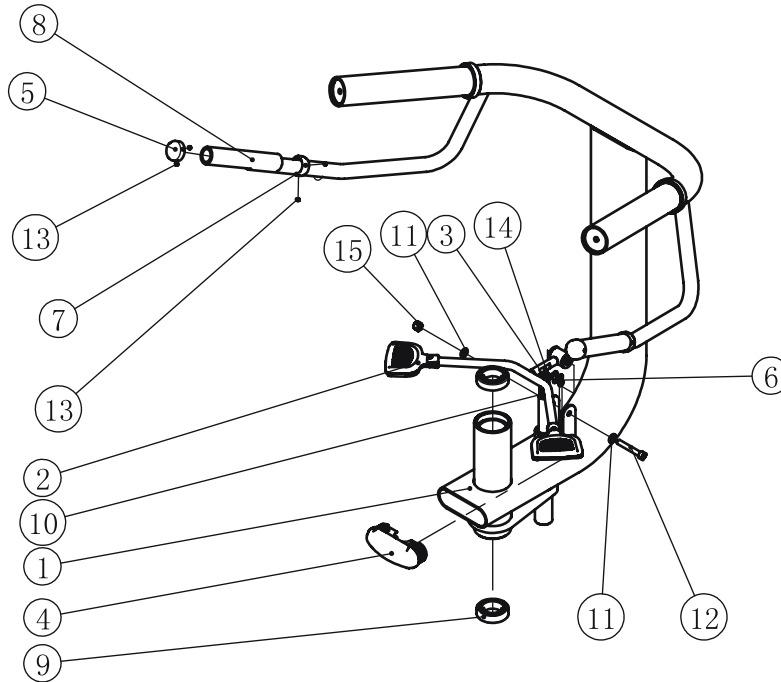

Item No.	Grade No.	Part No.	Description	QTY
1	3.1	FE97180300	Wriggled Frame	1
2	3.2	FE971810ASSY	Scaleboard	1
3	3.3	FE97183600	Pin	1
4	3.4	FE97142500	Plug RT40*118*3	1
5	3.5	FE97201700	Cap $\Phi 34*\Phi 25.8*16$	2
6	3.6	GB/T1243-199708BN19	Link 12.7	1
7	3.7	FE97212700V1	Aluminium Grip Ring	2
8	3.8	026-01PL0206-14	Grip $\Phi 31*\Phi 24*160$	2
9	3.9	GB2766006-2RSC3NBK	Bearing 6006-2RSC3NBK	2
10	3.10	SG8007M1200B	Spring $\Phi 1.5*\Phi 13*64$	1
11	3.11	GB958DN2	Flat Washer $\Phi 9*\Phi 16*1.6$	2
12	3.12	GB70M8*55N19	Socket Head Cap Screw M8*55	1
13	3.13	GB77M5*4N19	Screw M5*4	8
14	3.14	KPS18002701V1	Nut M20	1
15	3.15	NM8N19	Nylon Lock Nut M8	1

# Exploded View and Parts List

## Regulation Handle Frame ASSY

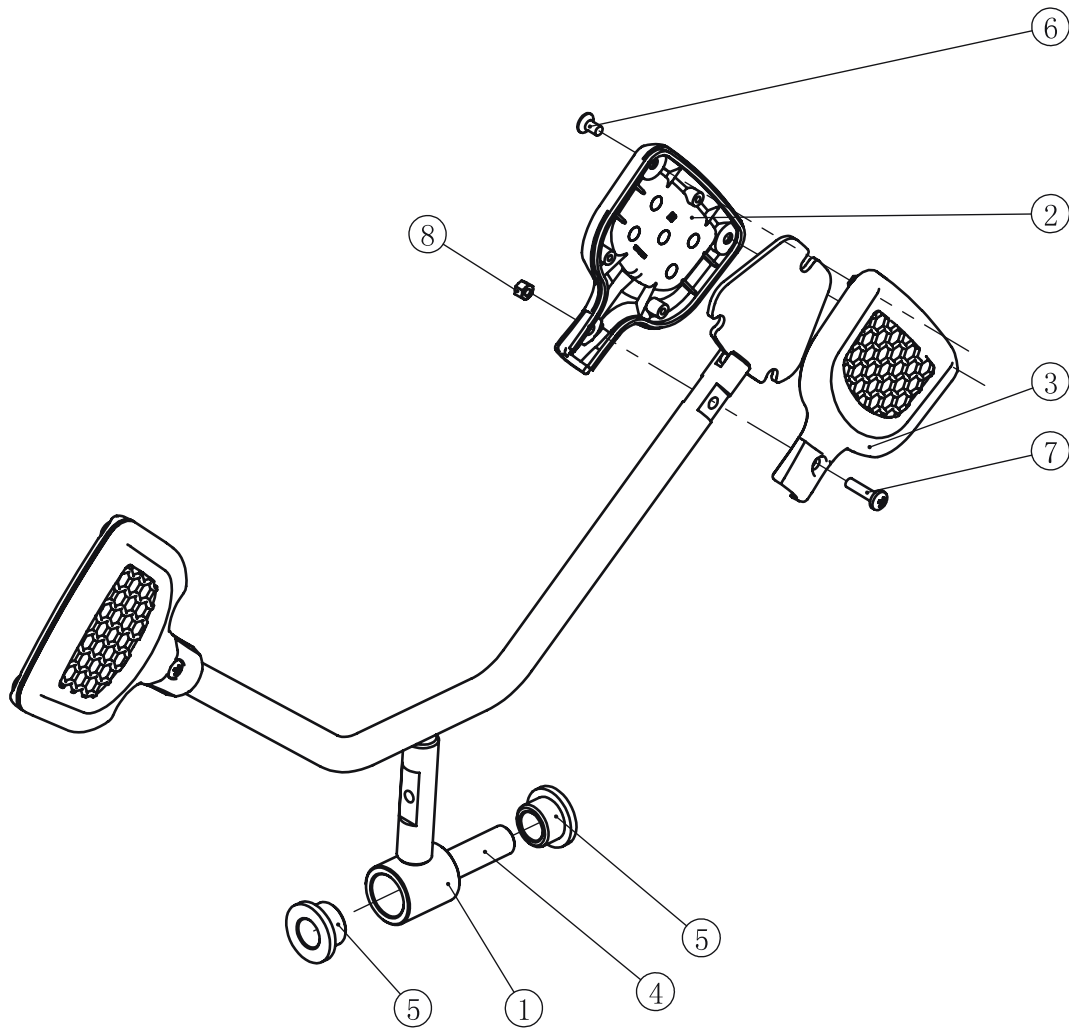

Item No.	Grade No.	Part No.	Description	QTY
1	3.2.1	FE97181000	Regulation Handle Frame	1
2	3.2.2	FE970114100	Under The Cover	1
3	3.2.3	FE970114200	Adjust The Cover	1
4	3.2.4	FE97141800	Spacer Bush $\Phi 12 * \Phi 8 * 35.5$	1
5	3.2.5	M01402000	Spacer $\Phi 25 * \Phi 12.2 * 13$	2
6	3.2.6	GB819M4*8DN2	Screw M4*8	4
7	3.2.7	GB818M4*16DN2NL	Screw M4*16	2
8	3.2.8	GB41M4DN2	Hexagon Nut M4	2

# Exploded View and Parts List

## Seat Frame ASSY

Item No.	Grade No.	Part No.	Description	QTY
1	4.1	FE97180400ASSY	Seat Frame II ASSY	1
2	4.2	FE97180800	Pulley Yoke	1
3	4.3	FE97180900	Turning Rolls	1
4	4.4	FE97181900	Guide $\Phi 25 \times 346$	2
5	4.5	FE97182700	Shaft	1
6	4.6	FE97184700	Sleeve $\Phi 34 \times \Phi 20 \times 14$	2
7	4.7	IT80031100	Cap $\Phi 34 \times 5$	2
8	4.8	PBG10006	Plug Bumper $\Phi 28 \times \Phi 25 \times 13$	1
9	4.9	SG500110400V2	4.5" Pulleys	1
10	4.10	PNLM6*35DHS2	Button Head Cap Screw M6*35	1
11	4.11	GB2766004-2RSC3NBK	Bearing 6004-2RSC3NBK	2
12	4.12	PNLM10*25DN20NL	Button Head Cap Screw M10*25	4
13	4.13	GB9310N19	Spring Washer $\Phi 10$	4
14	4.14	GB70BTM10*75DN18	Socket Head Cap Screw M10*75	1
15	4.15	GB70BTM10*50DN18	Socket Head Cap Screw M10*50	1
16	4.16	GB70M5*15DS20	Socket Head Cap Screw M5*15	1
17	4.17	DQ20DHS2B	Flat Washer $\Phi 20.2 \times \Phi 25 \times 1$	1
18	4.18	GB9510DN2	Flat Washer $\Phi 11 \times \Phi 20 \times 2$	2
19	4.19	NM10DN2	Nylon Lock Nut M10	2

# Exploded View and Parts List

## Seat Frame ASSY

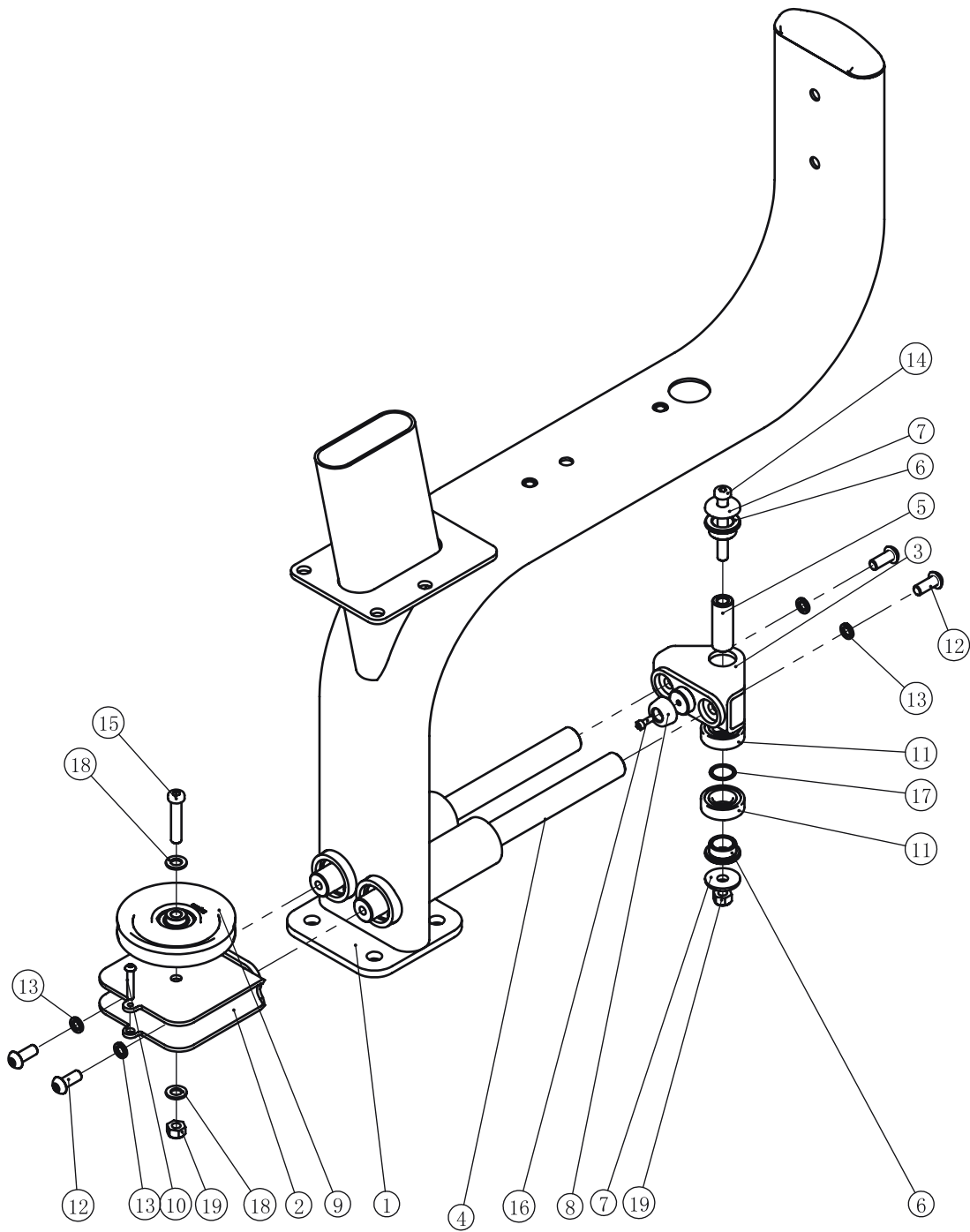

# Exploded View and Parts List

## Seat Frame II ASSY

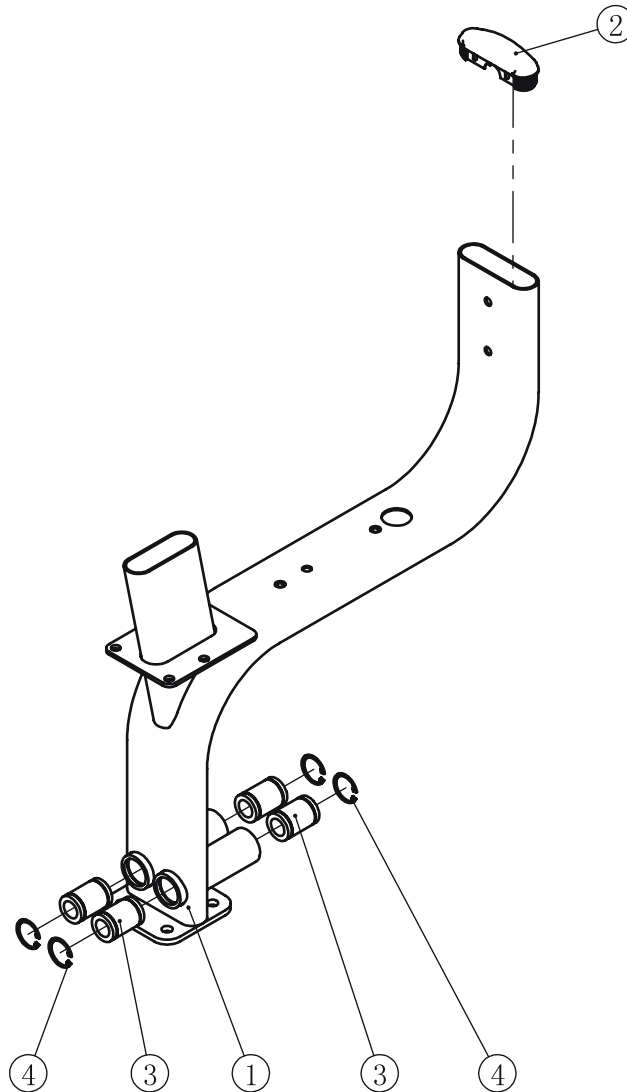

Item No.	Grade No.	Part No.	Description	QTY
1	4.1.1	FE97180400	Seat Frame	1
2	4.1.2	FE97211500	Plug RT40*133*3	1
3	4.1.3	WONSB25	Regulating Linear Bearing $\Phi 25$	4
4	4.1.4	GB893.140FH12	Retaining Ring $\Phi 40$	4

# Exploded View and Parts List

## Cam Frame ASSY

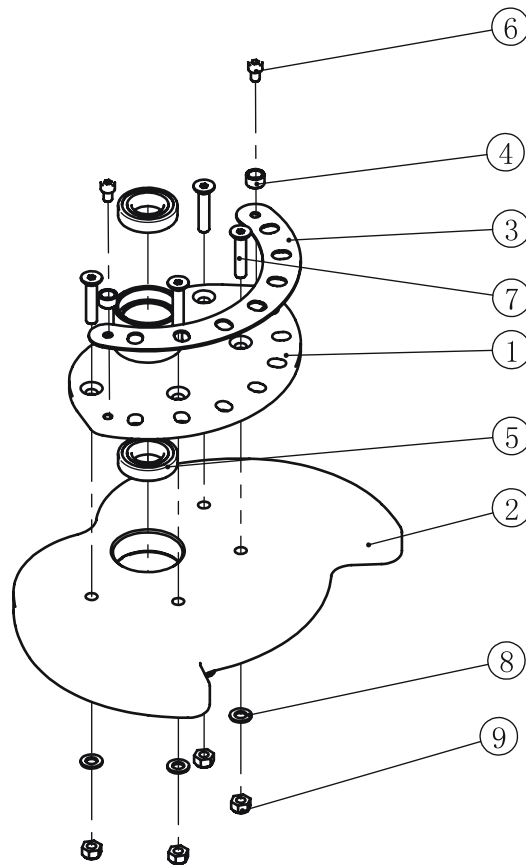

Item No.	Grade No.	Part No.	Description	QTY
1	5.1	FE97180500	Cam Frame	1
2	5.2	FE97183200	Cam	1
3	5.3	FE97183000	Plate	1
4	5.4	IN-S10111200	Rubber Sleeve $\Phi 17*10.5$	2
5	5.5	GB2766006-2RSC3NBK	Bearing 6006-2RSC3NBK	2
6	5.6	GB70M8*12DN20	Socket Head Cap Screw M8*12	2
7	5.7	CNLM10*50DN20	Flat Head Cap Screw M10*50	4
8	5.8	GB9510DN2	Flat Washer $\Phi 11*\Phi 20*2$	4
9	5.9	NM10DN2	Nylon Lock Nut M10	4

# Exploded View and Parts List

## Footrest Frame ASSY

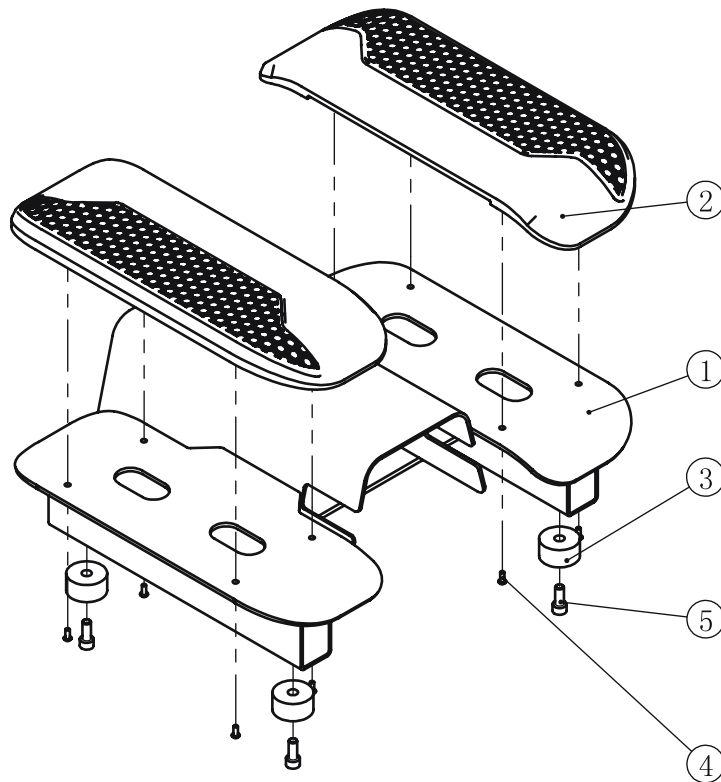

Item No.	Grade No.	Part No.	Description	QTY
1	6.1	FE97180600	Footrest Frame	1
2	6.2	FE97192400	Foot Cover Plate	2
3	6.3	BNH0514	Plug Bumper $\Phi 38*19.5$	4
4	6.4	PNLM4*10DN20	Button Head Cap Screw M4*10	8
5	6.5	GB70M8*20DN20	Socket Head Cap Screw M8*20	4

# Exploded View and Parts List

## Connect Frame ASSY

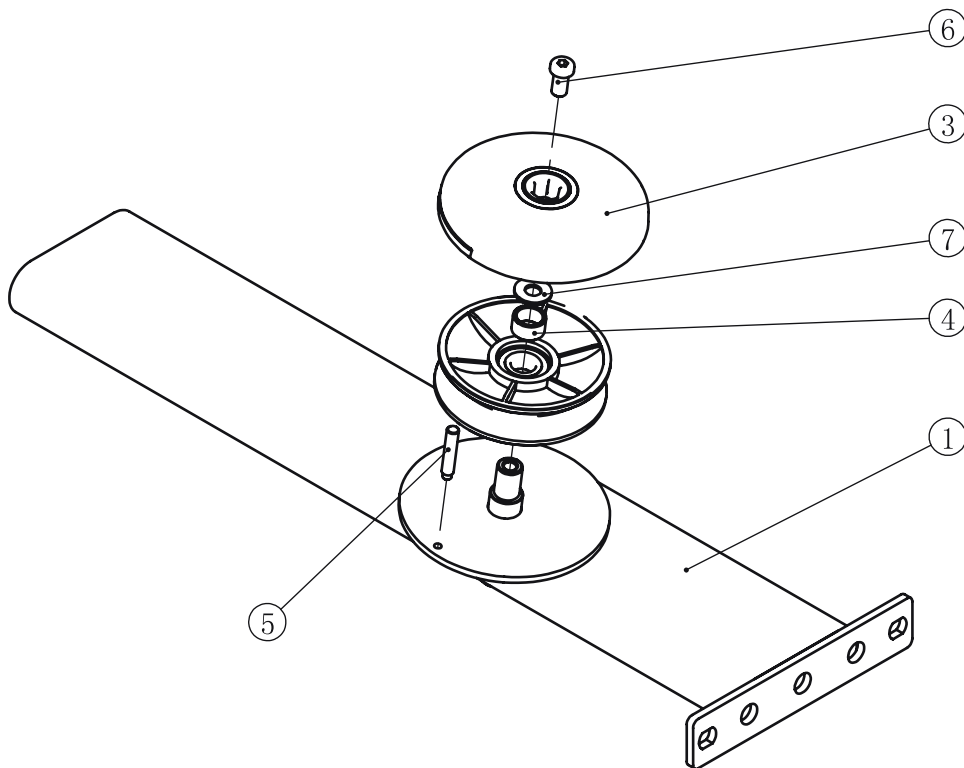

Item No.	Grade No.	Part No.	Description	QTY
1	7.1	FE97180700	Connect Frame	1
2	7.2	FE97123600	V Pulleys	1
3	7.3	FE97023800	Pulley Cover	1
4	7.4	FE97122200	Pulleys Spacer 2 $\Phi 22 \times 12.5$	1
5	7.5	FE97021800	Threaded column $\Phi 8 \times 42$	1
6	7.6	GB70BTM10*20DN18	Socket Head Cap Screw M10*20	1
7	7.7	DQ10N19B	Flat Washer $\Phi 11 \times \Phi 25 \times 2$	3



# Exploded View and Parts List

## Top Plate ASSY

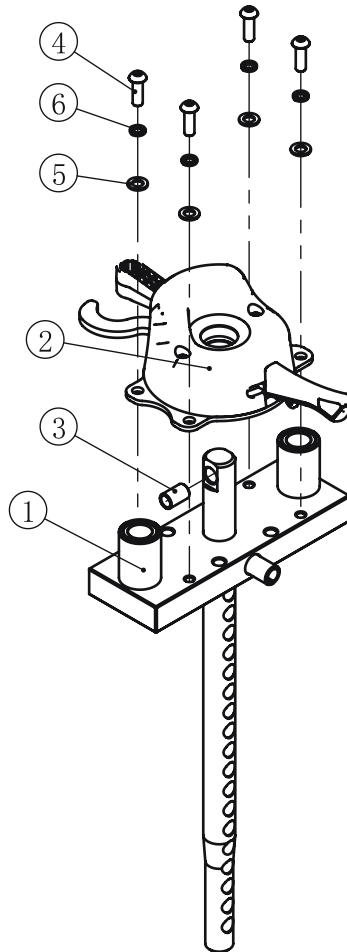

Item No.	Grade No.	Part No.	Description	QTY
1	30.1	FE97193000	Top Plate	1
2	30.2	FE971938ASSY	Counter Weight ASSY	1
3	30.3	FE972111500	Spacer $\Phi 13*\Phi 10.3*21$	1
4	30.4	PNLM8*25DN20	Button Head Cap Screw M8*25	4
5	30.5	GB958DN2	Flat Washer $\Phi 9*\Phi 16*1.6$	4
6	30.6	GB938N19	Spring Washer $\Phi 8$	4

# Exploded View and Parts List

## Counter Weight ASSY

Item No.	Grade No.	Part No.	Description	QTY
1	30.2.1	FE97192700	Plastic Base	1
2	30.2.2	FE97192800	Counter Weight Plastic Cover	1
3	30.2.3	FE97193500	Base Plate	1
4	30.2.4	FE97193600	Shifting Fork	1
5	30.2.5	FE97193700	Top Plate	1
6	30.2.6	FE97193800	Guide Frame	1
7	30.2.7	FE97193900	Short Spacer $\Phi 45 * \Phi 26 * 7.5$	1
8	30.2.8	FE97194000	Stop Collar	1
9	30.2.9	FE97194100	Top Plastic Cover	1
10	30.2.10	FE97194200	Base Plastic Cover	1
11	30.2.11	CWRVL0251800	Steel Ball Support Base	2
12	30.2.12	CWRVL0251900	Spring $\Phi 1.2 * \Phi 13 * 11$	3
13	30.2.13	GB3088G20	Steel Ball	2
14	30.2.14	PNLM8*80DN20	Button Head Cap Screw M8*80	2
15	30.2.15	PNLM8*45DN20	Button Head Cap Screw M8*45	2
16	30.2.16	PNLM4*12DN20	Button Head Cap Screw M4*12	2
17	30.2.17	PNLM5*15DN20	Button Head Cap Screw M5*15	2
18	30.2.18	GB958DN2	Flat Washer $\Phi 9 * \Phi 16 * 1.6$	4
19	30.2.19	GB938N19	Spring Washer $\Phi 8$	4

# Exploded View and Parts List

## Counter Weight ASSY

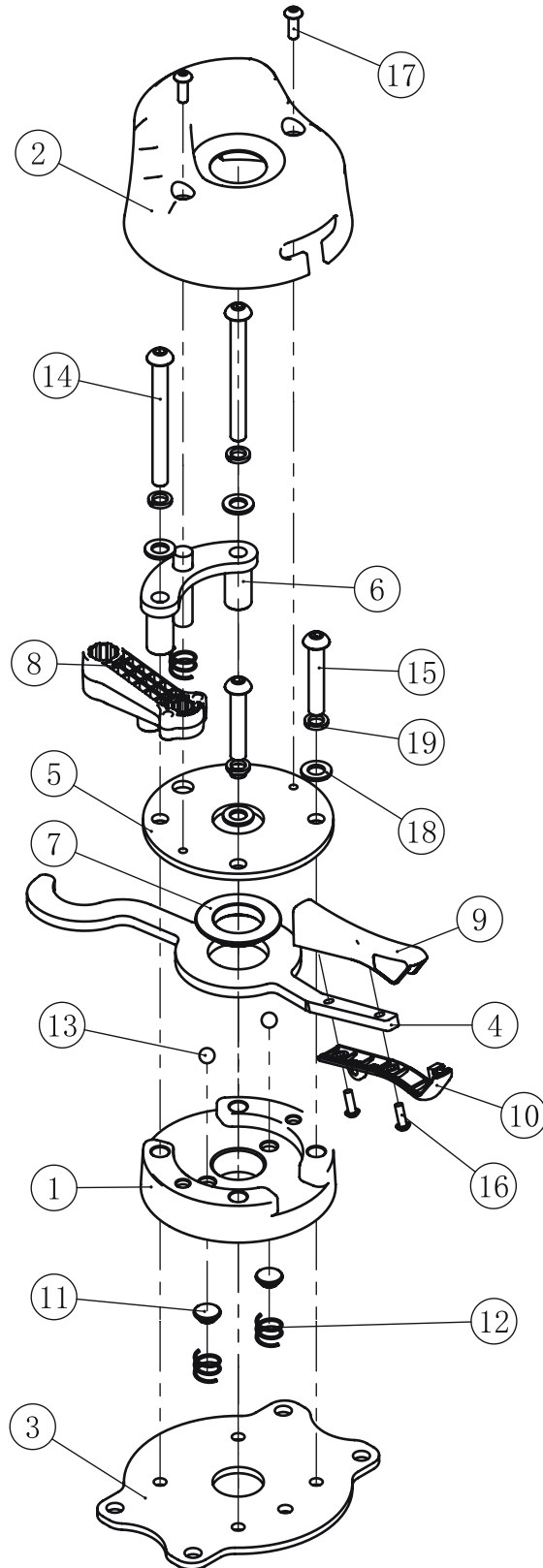

# Exploded View and Parts List

## Head Pad ASSY

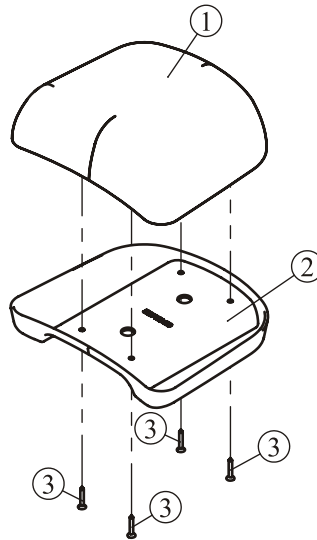

Item No.	Grade No.	Part No.	Description	QTY
1	19.1	FE97123300	Head Pad	1
2	19.2	FE97123400	Head Pad Cover	1
3	19.3	GB846ST3.5*25DN	Screw ST3.5*25	4

## Training Placard Cover ASSY

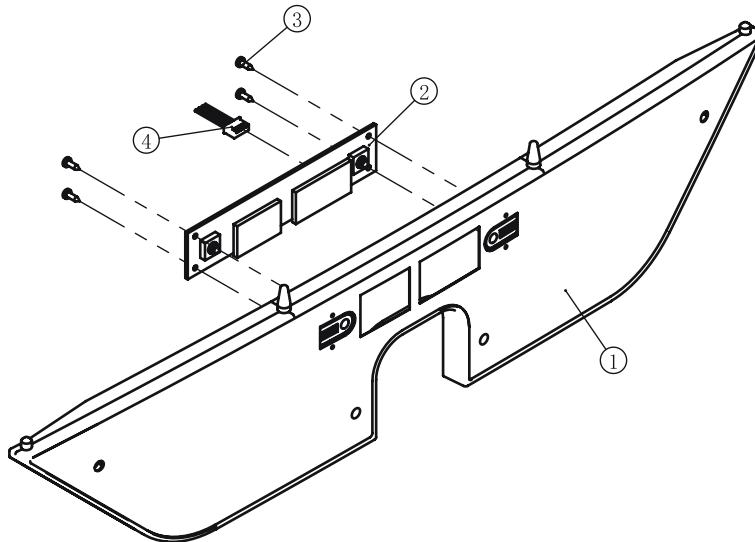

Item No.	Grade No.	Part No.	Description	QTY
1	14.1	FE97052600	Training Placard Cover	1
2	14.2	B117	Console PCB	1
3	14.3	GB845ST2.9*9.5DS	Screw ST2.9*9.5	4
4	14.4	L350XHP/SMY-4	Sensor 4C*22#350mm	1

# Exploded View and Parts List

## Belt ASSY

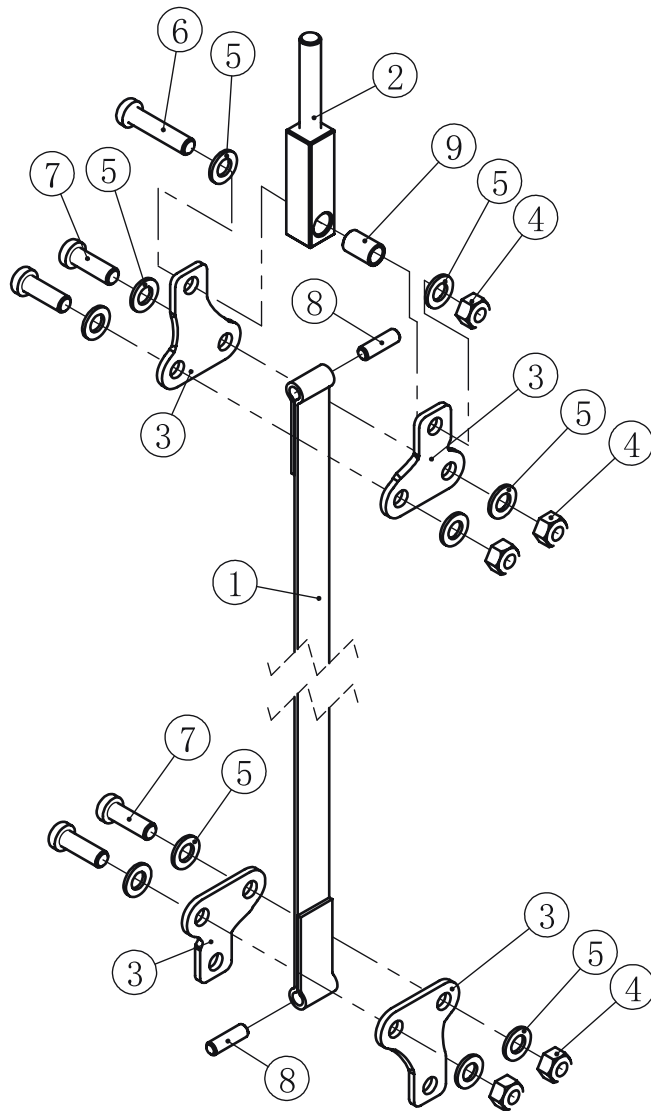

Item No.	Grade No.	Part No.	Description	QTY
1	26.1	FE97214500	Belt	1
2	26.2	FE97214700	Square Adjustment Lever	1
3	26.3	FE97193300	Fastening Plate	4
4	26.4	NM10DN2	Nylon Lock Nut M10	5
5	26.5	GB9510DN2	Flat Washer $\Phi 11 * \Phi 20 * 2$	10
6	26.6	GB70BTM10*45DN18	Socket Head Cap Screw M10*45	1
7	26.7	GB70BTM10*30DN18	Socket Head Cap Screw M10*30	4
8	26.8	200105110402	Locating Pin $\Phi 8 * 28$	2
9	26.9	FE972111500	Spacer $\Phi 13 * \Phi 10.3 * 21$	1

# Exploded View and Parts List

## 5LBS Counter Weight ASSY

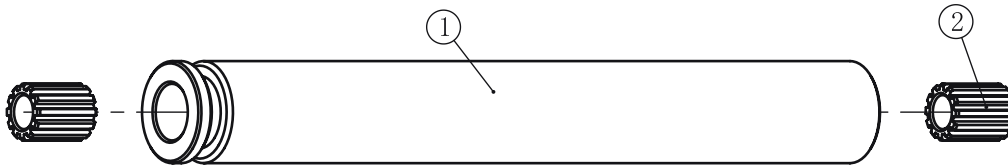

Item No.	Grade No.	Part No.	Description	QTY
1	19.1	FE97213500	5LBS Counter Weight	1
2	19.2	CXT-1001900V1	Guide Sleeve	2

## The Moving Block ASSY

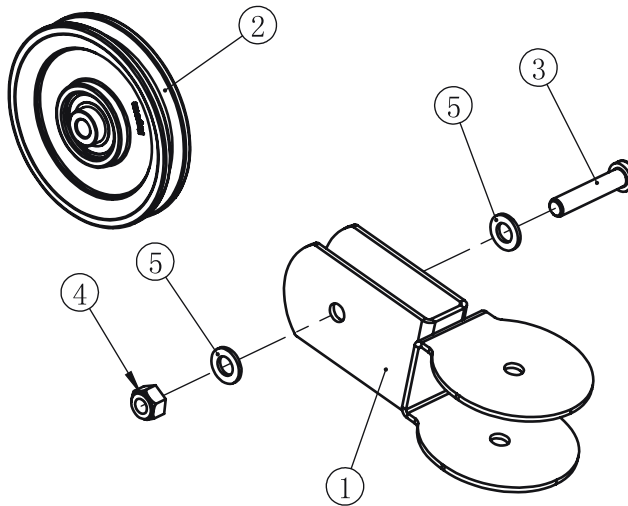

Item No.	Grade No.	Part No.	Description	QTY
1	32.1	FE97203000	The Moving Block	1
2	32.2	SG500110400V2	4.5" Pulleys	1
3	32.3	GB70BTM10*50DN18	Socket Head Cap Screw M10*50	1
4	32.4	NM10DN2	Nylon Lock Nut M10	1
5	32.5	GB9510DN2	Flat Washer $\Phi 11 * \Phi 20 * 2$	2

# Exploded View and Parts List

## Overall

Item No.	Part No.	Description	QTY
1	FE971801ASSY	Weight Stack Frame ASSY	1
2	FE971802ASSY	Main Frame ASSY	1
3	FE971803ASSY	Wriggled Frame ASSY	1
4	FE971804ASSY	Seat Frame ASSY	1
5	FE971805ASSY	Cam Frame ASSY	1
6	FE971806ASSY	Footrest Frame ASSY	1
7	FE971807ASSY	Connect Frame ASSY	1
8	FE97010500	Side Connecting Frame	1
9	FE972030ASSY	Moving Block ASSY	1
10	FE97214000	Narrow Belt Pulley $\Phi 76$	1
11	FE972145ASSY	Belt ASSY	1
12	FE97184000	Cable ASSY	1
13	FE97053500	Cup Holder	1
14	FE97053600	Bracket of Cup Holder	1
15	FE97215000V1	Guide Rod $\Phi 19$	2
16	FE97194300	Guide Rod $\Phi 14$	1
17	FE97211400	Underside support plate	1
18	FE97011600V1	Top Cover	1
19	FE972135ASSY	5LBS Counter Weight ASSY	1
20	FE97192500	Plastic Cover I	2
21	FE97192600	Plastic Cover II	1
22	FE97183300	Cover Plate	1
23	FE97183400	Cover Plate	1
24	FE97123500	4.5" Pulleys	1
25	FE97182600	Plate	1
26	FE97082200	Seat Pad	1
27	FE971233ASSY	Head Pad ASSY	1
28	FE971829ASSY	Foam ASSY	2
29	FE97182000	Knee Pad	1
30	FE971930ASSY	Top plate ASSY	1
31	FE9705270005	Front Lower Cover	1
32	FE97052500	Front Shroud	2
33	FE97052800	Back Shroud	1
34	FE97052900	Back Lower Cover	1
35	FE970526ASSY	Training Placard Cover ASSY	1
36	FE97123800	Selector Pin W/Coil	1
37	FE97194400	Limiting Tube $\Phi 22*2*66$	1
38	FE97211900	Cap $\Phi 60$	2
39	CWRVL0251000	Plug Bumper $\Phi 14*\Phi 40*25.4$	1
40	CWRVL0250900	Flat Washer $\Phi 15*\Phi 40*3$	1
41	IN-D10132900	Plug Bumper $\Phi 76*60$	2
42	FE97214800	Belt Rubber Sleeve $\Phi 17*49$	2

# Exploded View and Parts List

## Overall

Item No.	Part No.	Description	QTY
43	FE97213400	Rubber Sleeve $\Phi 30 \times 65$	2
44	FE97053700	Plastic End Cap	1
45	FE97122300	Threaded column $\Phi 8 \times 30$	1
46	FE97216900	Spacer Pin $\Phi 15 \times \Phi 8 \times 65.5$	2
47	NXSC-010903	Tube $\Phi 42 \times \Phi 32 \times 5$	1
48	FE97122100	Pulleys Spacer 2 $\Phi 22 \times \Phi 17.5 \times 7.5$	1
49	IN-D20020802	Cable Connector	1
50	L090PB5000	Joint Bearing	1
51	SG80106100	Ring $\Phi 18 \times \Phi 12.3 \times 4$	1
52	GB70BTM10*25DN18NL	Socket Head Cap Screw M10*25	14
53	GB70BTM10*45DN18	Socket Head Cap Screw M10*45	2
54	GB70BTM10*65DN18	Socket Head Cap Screw M10*65	1
55	GB70BTM10*70DN18NL	Socket Head Cap Screw M10*70	3
56	GB70BTM12*35DN18NL	Socket Head Cap Screw M12*35	1
57	GB70BTM12*105DN18	Socket Head Cap Screw M12*105	3
58	GB70BTM12*120DN18NL	Socket Head Cap Screw M12*120	2
59	GB70BTM12*180DN18NL	Socket Head Cap Screw M12*180	4
60	GB70M8*45*45N19	Socket Head Cap Screw M8*45	2
61	GB77M8*6DS2	Screw M8*6	2
62	GB77M8*8DS18	Screw M8*8	1
63	CNLM10*25DN20	Flat Head Cap Screw M10*25	2
64	PNLM8*25DN20	Button Head Cap Screw M8*25	2
65	PNLM6*12DN20	Button Head Cap Screw M6*12	5
66	PNLM6*15DN20	Button Head Cap Screw M6*15	6
67	PNLM6*20DN20	Button Head Cap Screw M6*20	11
68	GB956DN2	Flat Washer $\Phi 6.6 \times \Phi 12 \times 1.6$	17
69	GB958DN2	Flat Washer $\Phi 9 \times \Phi 16 \times 1.6$	4
70	GB9510DN2	Flat Washer $\Phi 11 \times \Phi 20 \times 2$	21
71	GB9512DN2	Flat Washer $\Phi 13 \times \Phi 24 \times 2.5$	18
72	GB936N19	Spring Washer $\Phi 6$	2
73	GB938N19	Spring Washer $\Phi 8$	2
74	GB9310N19	Spring Washer $\Phi 10$	1
75	NM10DN2	Nylon Lock Nut M10	3
76	NM12DN2	Nylon Lock Nut M12	8
77	GB8966FH12	Shaft Ring Opening $\Phi 6$	2
120	NBS4DHS	Hex Key S=4	1
121	NBS5DHS	Hex Key S=5	1
122	NBS6DHS	Hex Key S=6	1
123	NBS8DHS	Hex Key S=8	1
124	LW200BS	Wrench $\Phi 6 \times 117$	1
125	YHY	Lube	1
126	NBS3DHS	Hex Key S=3	1
166	HFOPT900-04A0602	Tension Spring	2



# Exploded View and Parts List

## Overall

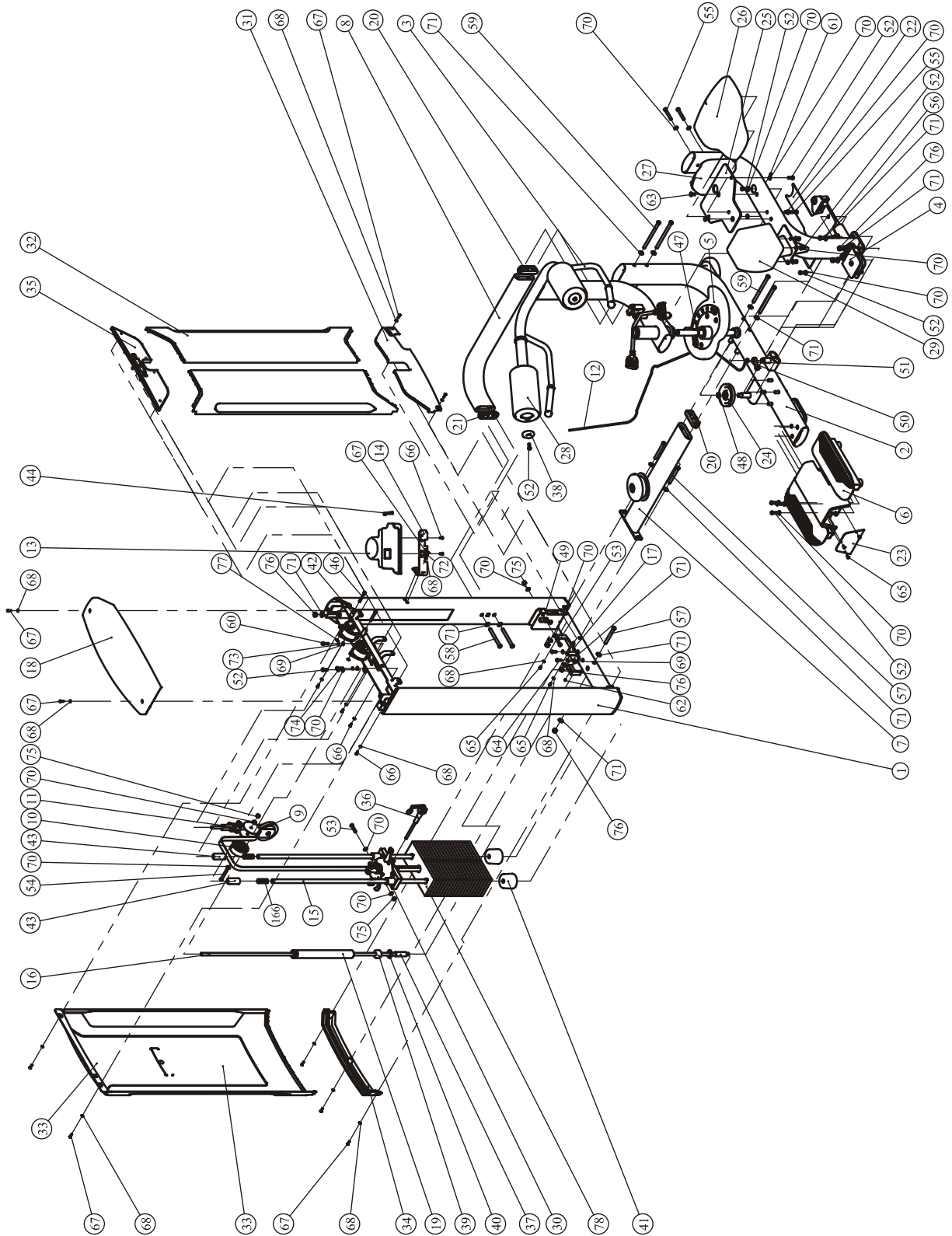

# Measurement Guide

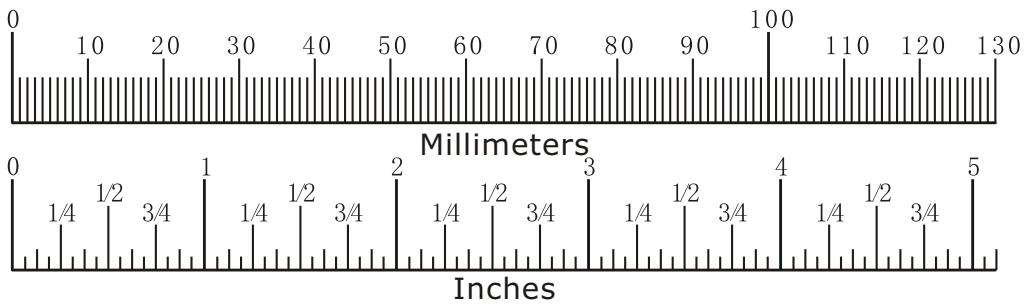
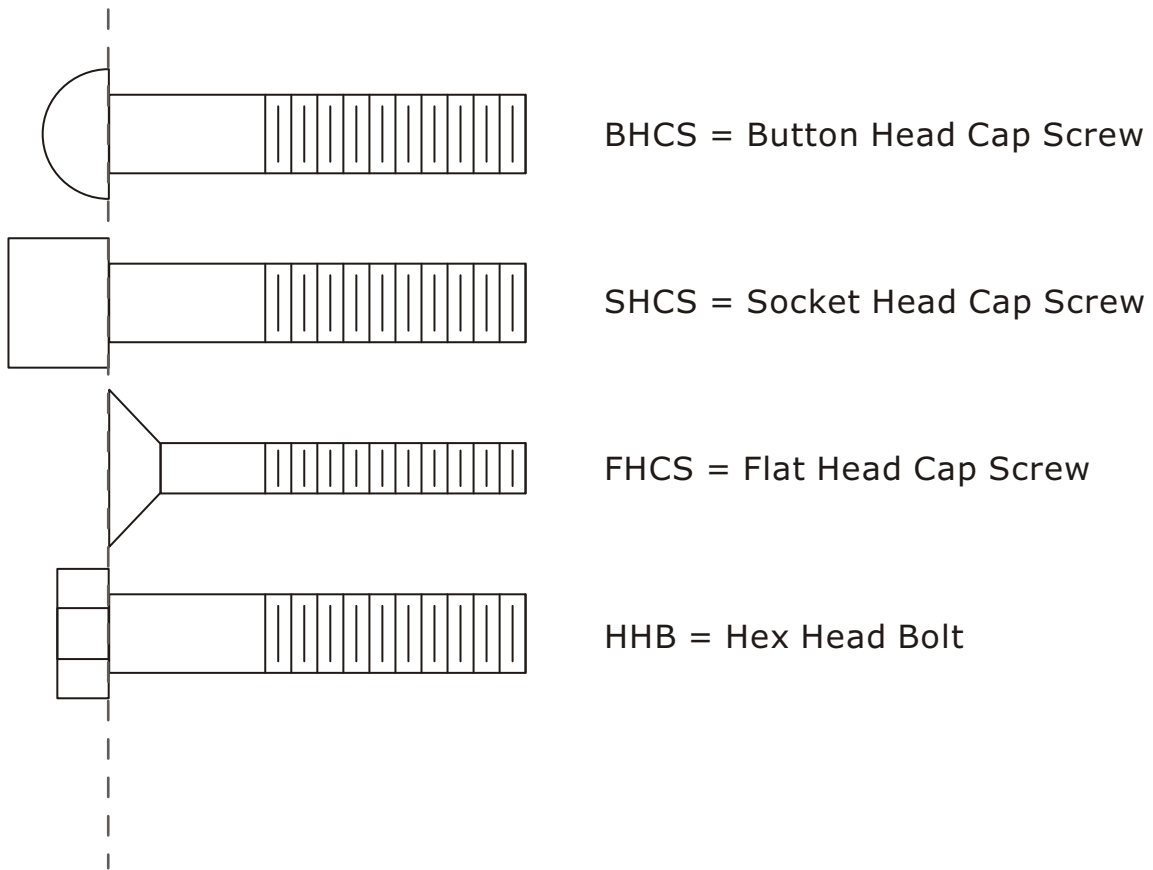

Diameter of bolt (mm/inch)	M6(1/4")	M8(5/16")	M10(3/8")	M12(1/2")	M16(5/8")
Tightening torque (N.m)	9~12	22~30	45~59	78~104	193~257
Operational methods for adult men	The strength of the wrist	The strength of the wrist and forearm	The strength of the entire arm	The strength of the arm and upper body	with all strength

# Assembly Instructions

Assembly of the equipment takes professional installers about 2 hours. If this is the first time you have assembled this type of equipment, plan to spend more time. It is strongly recommended to assemble the equipment by professional installers. You may find it quicker, safer, easier to assemble this equipment with the help of a friend, as some of components may be large, heavy or awkward to handle alone. It is important that you assemble your product in a clean, clear, uncluttered area. This will enable you to move around the product while you are fitting components and reduce the possibility of injury during assembly.

## **NOTE**

As with any assembled part, proper alignment and adjustment is critical. While tightening the fasteners, be sure to leave room for adjustments. Do not fully tighten the fasteners until instructed to do so. Be careful to assemble the components in the sequence presented in this guide.

# Assembly

## STEP 1

1. Attach The Connect Frame ASSY (#7) to The Weight Stack Frame ASSY (#1) using:  
two M12\*105 SHCS (#57)                      two M12 Nylon Lock Nut (#76)  
four  $\Phi 13*\Phi 24*2.5$  Flat Washer (#71)
2. Attach one M12\*105 SHCS (#57) and one M12 Nylon Lock Nut (#76) and two  $\Phi 13*\Phi 24*2.5$  Flat Washer (#71) to The Weight Stack Frame ASSY (#1).
3. Attach The Side Connecting Frame (#8) to The Weight Stack Frame ASSY (#1) using:  
two M12\*120 SHCS (#57)                      two  $\Phi 13*\Phi 24*2.5$  Flat Washers (#71)  
one Plastic Cover II (#21)
4. Attach Main Frame ASSY (#2) to The Connect Frame ASSY (#7) and The Side Connecting Frame (#8) using:  
four M12\*180 SHCS (#59)                      four  $\Phi 13*\Phi 24*2.5$  Flat Washers (#71)  
two Plastic Cover (#20)

**Note: Wrench Tighten Bolts and Nylon Lock Nuts.**

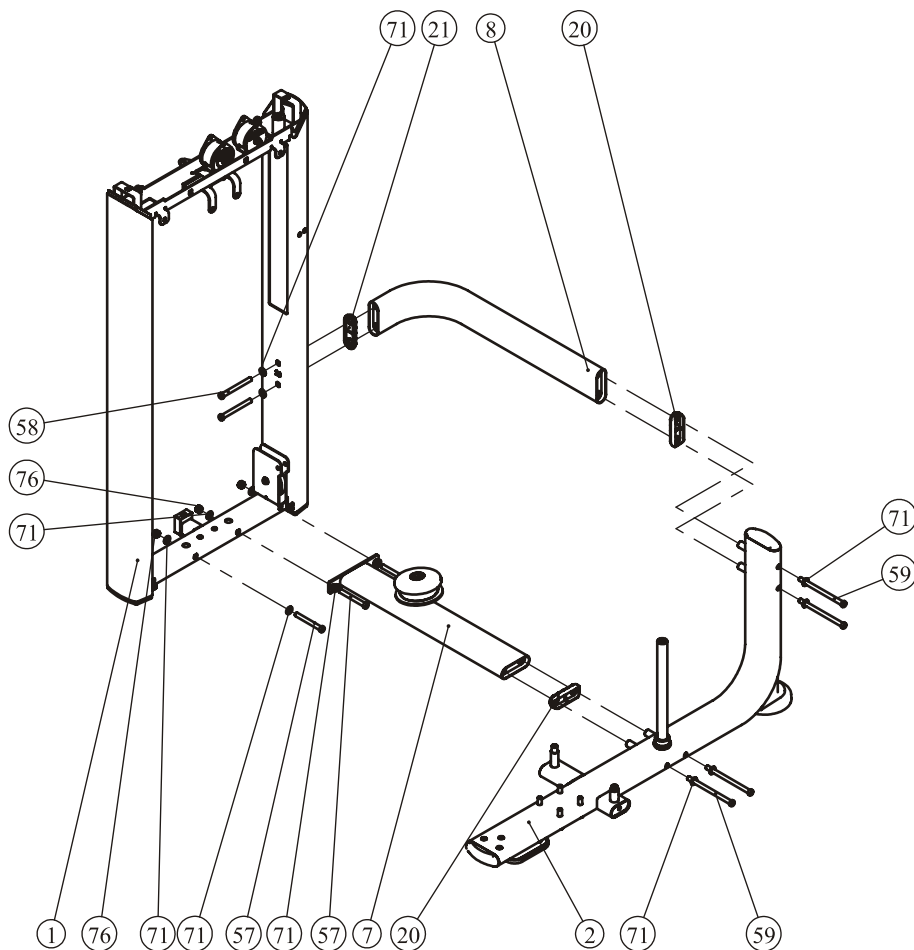

# Assembly

## STEP 2

1. Attach The Cam Frame ASSY (#5) to The Main Frame ASSY (#2).
2. Attach The Wriggled Frame ASSY (#3) to The Main Frame ASSY (#2) using:  
one Tube  $\Phi 42 \times \Phi 32 \times 5$  (#47)
3. Attach The Seat Frame ASSY (#4) to The Main Frame ASSY (#2) using:  
one Socket Head Cap Screw M10\*25 (#52)  
one Flat Washer  $\Phi 11 \times \Phi 20 \times 2$  (#70)  
four Flat Washer  $\Phi 13 \times \Phi 24 \times 2.5$  (#71)  
four Nylon Lock Nut M12 (#76)  
two Screw M8\*6 (#61)

**Note: Wrench Tighten Bolts and Nylon Lock Nuts.**

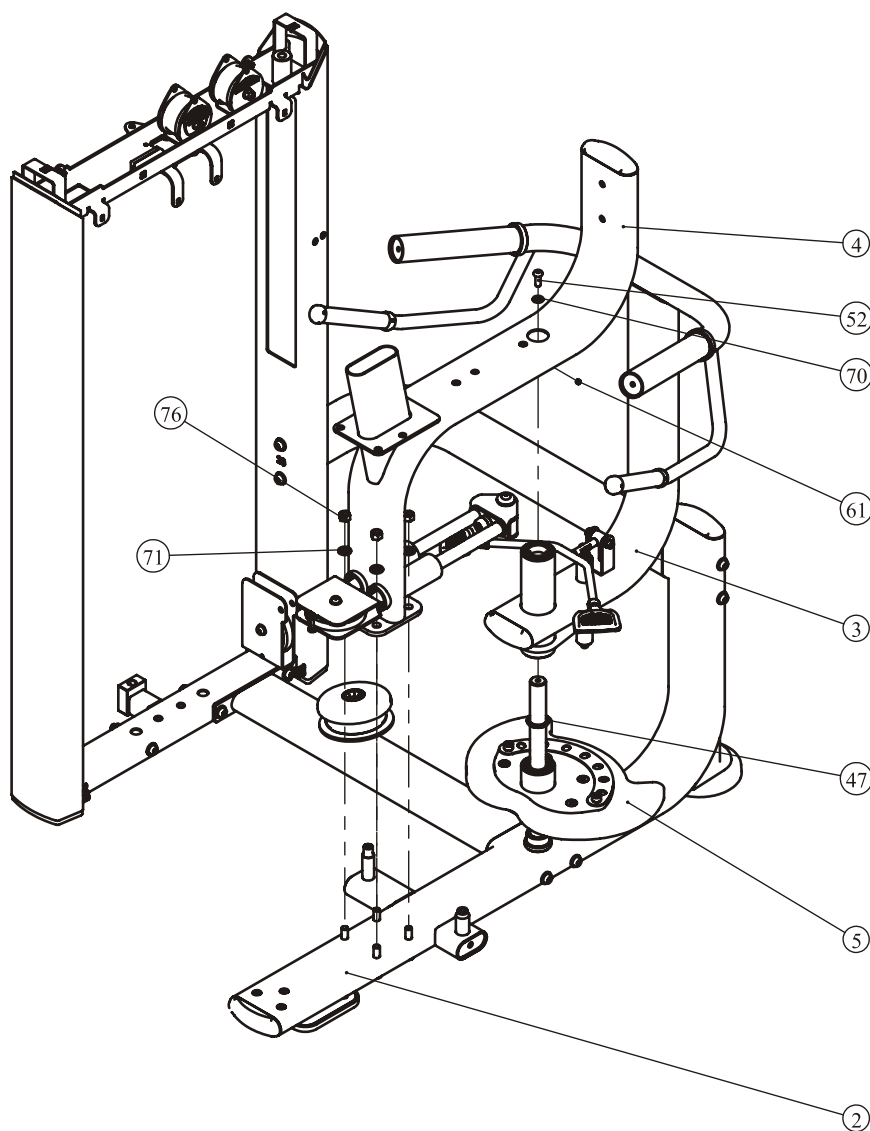

# Assembly

## STEP 3

1. Attach The Underside Support Plate (#17) to The Weight Stack Frame ASSY (#1) using:  
two M8\*25 BHCS (#64)  
two  $\Phi 9 \times \Phi 16 \times 1.6$  Flat Washers (#69)
2. Attach The Front Lower Cover (#31) to The Weight Stack Frame ASSY (#1) and The Underside Support Plate (#17) using:  
two M6\*20 BHCS (#67)  
two M6\*12 BHCS (#65)  
four  $\Phi 6.6 \times \Phi 12 \times 1.6$  Flat Washers (#68)

**Note: Wrench Tighten Bolts and Nylon Lock Nuts.**

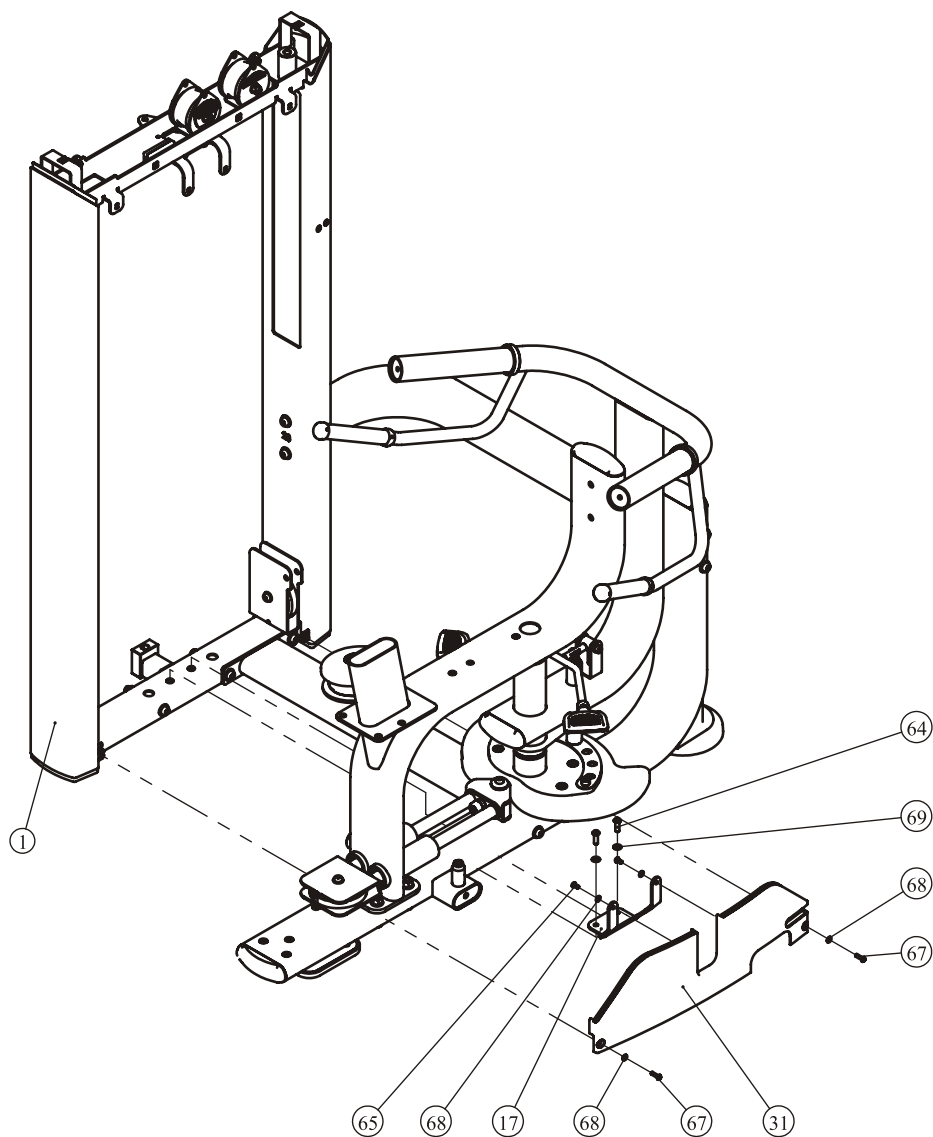

# Assembly

## STEP 4 Here is the assembly instruction for 10LBSx15PCS Weights !

### 1. Attach:

two  $\Phi 19$  Guide Rods (#15)

fifteen Weight Plate 10LBS (#78)

one Top Plate ASSY (#30)

to The Weight Stack Frame ASSY (#1) using:

two M8\*45 SHCS (#60)

two Spring Washer  $\Phi 8$  (#73)

two Tension Spring (#166)

two  $\Phi 76*60$  Weight Rubber Bumpers (#41)

two Weight Stack Space (#79)

two  $\Phi 9*\Phi 16*1.6$  Flat Washers (#69)

two  $\Phi 30*65$  Rubber Sleeve (#43)

### 2. Attach The Selector Pin W/Coil (#36) to The Top Plate ASSY (#30).

### 3. Loosen one M8\*8 Screw (#62), and Attach:

one  $\Phi 14*1296$  Guide Rod (#16)

to The Weight Stack Frame ASSY (#1) using:

one  $\Phi 22*2*66$  Limiting tube (#37)

one  $\Phi 14*\Phi 40*25.4$  Plug Bumper (#39)

one  $\Phi 10$  Spring Washer (#74)

one 5LBS Counter Weight (#19)

one  $\Phi 15*\Phi 40*3$  Flat Washer (#40)

one M10\*25 SHCS (#52)

one  $\Phi 11*\Phi 20*2$  Flat Washer (#70)

### 4. Wrench Tighten M8\*8 Screw (#62).

**Note: Wrench Tighten Bolts and Nylon Lock Nuts.**

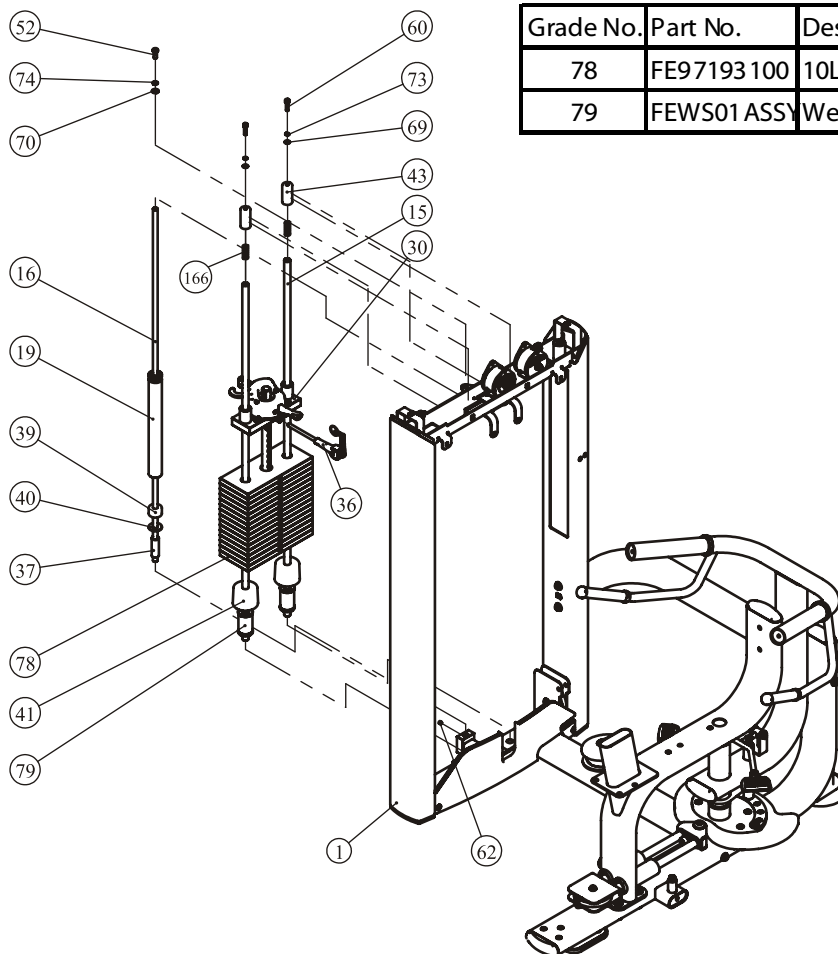

Grade No.	Part No.	Description	QTY
78	FE97193 100	10LBS Weight Plate	15
79	FEWS01 ASSY	Weight Stack Space ASSY	2

# Assembly

## STEP 4 Here is the assembly instruction for 10LBSx19PCS Weights !

### 1. Attach:

- |  |  |
|--|--|
| two $\Phi 19$ Guide Rods (#15)             | two $\Phi 76*60$ Weight Rubber Bumpers (#41) |
| nineteen Weight Plate 10LBS (#78)          | one Top Plate ASSY (#30)                     |
| to The Weight Stack Frame ASSY (#1) using: |  |
| two M8*45 SHCS (#60)                       | two $\Phi 9*\Phi 16*1.6$ Flat Washers (#69)  |
| two Spring Washer $\Phi 8$ (#73)           | two $\Phi 30*65$ Rubber Sleeve (#43)         |
| two Tension Spring (#166)                  |  |

### 2. Attach The Selector Pin W/Coil (#36) to The Top Plate ASSY (#30).

### 3. Loosen one M8\*8 Screw (#62), and Attach:

- |  |   |
|--|---|
| one $\Phi 14*1296$ Guide Rod (#16)           | one 5LBS Counter Weight (#19)             |
| to The Weight Stack Frame ASSY (#1) using:   |   |
| one $\Phi 22*2*66$ Limiting tube (#37)       | one $\Phi 15*\Phi 40*3$ Flat Washer (#40) |
| one $\Phi 14*\Phi 40*25.4$ Plug Bumper (#39) | one M10*25 SHCS (#52)                     |
| one $\Phi 10$ Spring Washer (#74)            | one $\Phi 11*\Phi 20*2$ Flat Washer (#70) |

### 4. Wrench Tighten M8\*8 Screw (#62).

**Note: Wrench Tighten Bolts and Nylon Lock Nuts.**

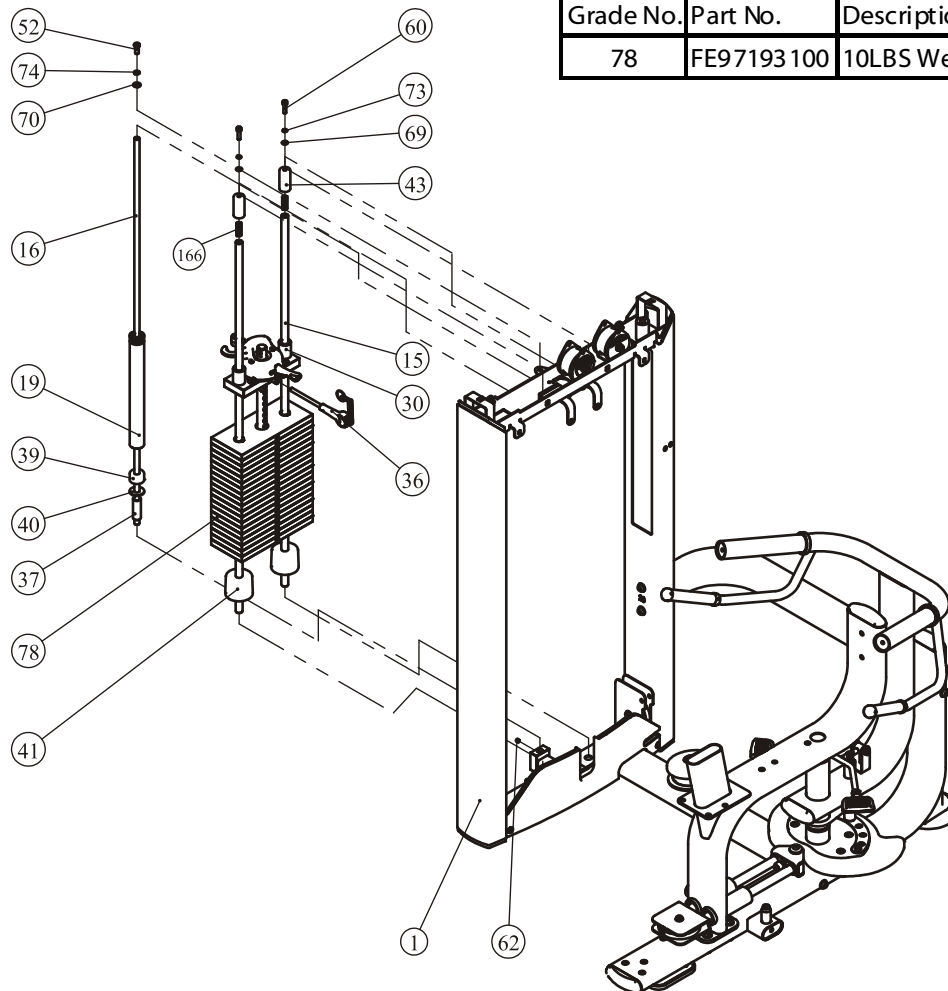

Grade No.	Part No.	Description	QTY
78	FE97193 100	10LBS Weight Plate	19



# Assembly

Please assemble according to the actual **Weights** you buy !

## 10LBS×15PCS

## 10LBS×19PCS

Grade No.	Part No.	Description	QTY	Grade No.	Part No.	Description	QTY
1	FE971930ASSY	10LBS Top Plate ASSY	1	1	FE971930ASSY	10LBS Top Plate ASSY	1
2	FE97193100	10LBS Weight Plate	15	2	FE97193100	10LBS Weight Plate	19
3	IN-D10132900	Weight Rubber Bumpers	2	3	IN-D10132900	Weight Rubber Bumpers	2
4	FEWS01ASSY	Weight Stack Space	2				

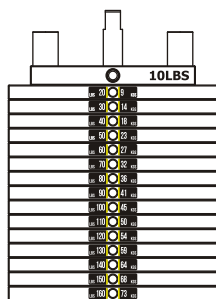
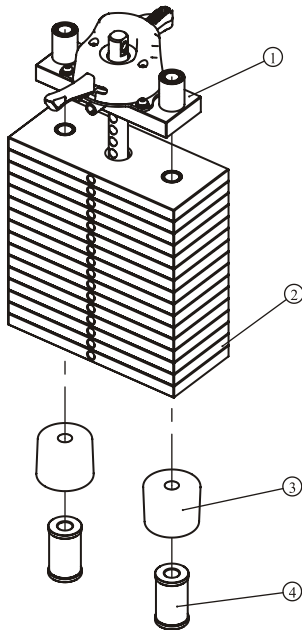

20-160LBS

LBS 20	9	KGS
LBS 30	14	KGS
LBS 40	18	KGS
LBS 50	23	KGS
LBS 60	27	KGS
LBS 70	32	KGS
LBS 80	36	KGS
LBS 90	41	KGS
LBS 100	45	KGS
LBS 110	50	KGS
LBS 120	54	KGS
LBS 130	59	KGS
LBS 140	64	KGS
LBS 150	68	KGS
LBS 160	73	KGS
LBS 170	77	KGS
LBS 180	82	KGS
LBS 190	86	KGS
LBS 200	91	KGS
LBS 210	95	KGS
LBS 220	100	KGS
LBS 230	104	KGS

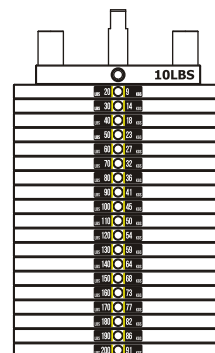
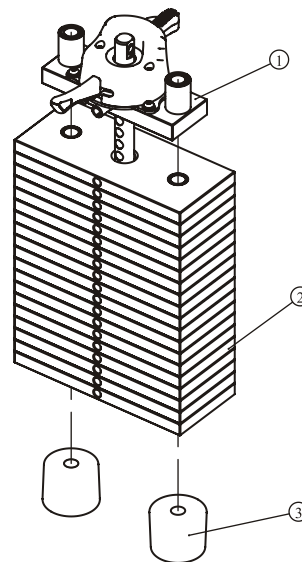

20-200LBS

Weight plate sticker paste schematic diagram

# Assembly

Please assemble according to the actual **Weights** you buy !

## 15LBS×15PCS

## 15LBS×19PCS

Grade No.	Part No.	Description	QTY	Grade No.	Part No.	Description	QTY
1	FE971930ASSY	10LBS Top Plate ASSY	1	1	FE971930ASSY	10LBS Top Plate ASSY	1
2	FE97193200	15LBS Weight Plate	15	2	FE97193200	15LBS Weight Plate	19
3	IN-D10132900	Weight Rubber Bumpers	2	3	IN-D10132900	Weight Rubber Bumpers	2
4	FEWS01ASSY	Weight Stack Space	2				

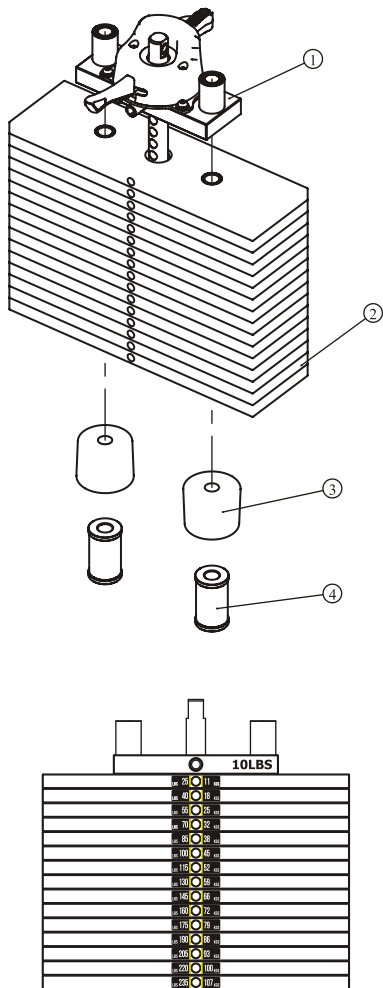

25-235LBS

LBS 25	11	KGS
LBS 40	18	KGS
LBS 55	25	KGS
LBS 70	32	KGS
LBS 85	38	KGS
LBS 100	45	KGS
LBS 115	52	KGS
LBS 130	59	KGS
LBS 145	66	KGS
LBS 160	72	KGS
LBS 175	79	KGS
LBS 190	86	KGS
LBS 205	93	KGS
LBS 220	100	KGS
LBS 235	107	KGS
LBS 250	113	KGS
LBS 265	120	KGS
LBS 280	127	KGS
LBS 295	134	KGS
LBS 310	141	KGS
LBS 325	147	KGS

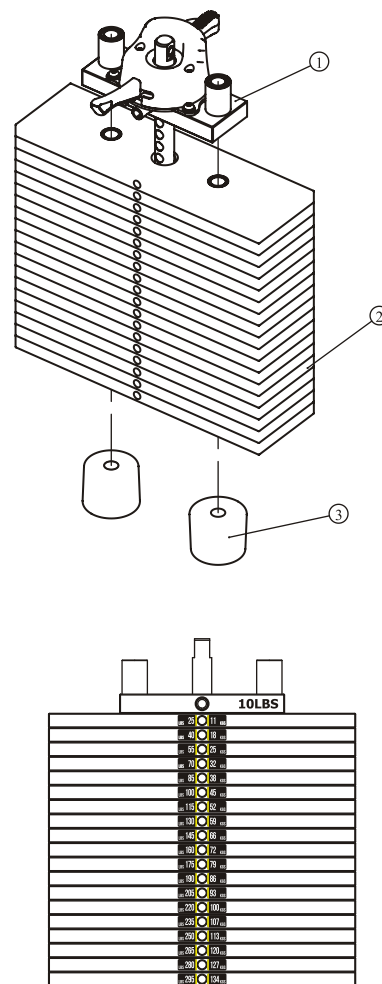

25-295LBS

Weight plate sticker paste schematic diagram

# Assembly

Please assemble according to the actual **Weights** you buy !

## 10LBS×15PCS

## 10LBS×19PCS

Grade No.	Part No.	Description	QTY	Grade No.	Part No.	Description	QTY
1	FE970230ASSY	40LBS Top Plate ASSY	1	1	FE970230ASSY	40LBS Top Plate ASSY	1
2	FE97193100	10LBS Weight Plate	15	2	FE97193100	10LBS Weight Plate	19
3	IN-D10132900	Weight Rubber Bumpers	2	3	IN-D10132900	Weight Rubber Bumpers	2
4	FEWS01ASSY	Weight Stack Space	2				

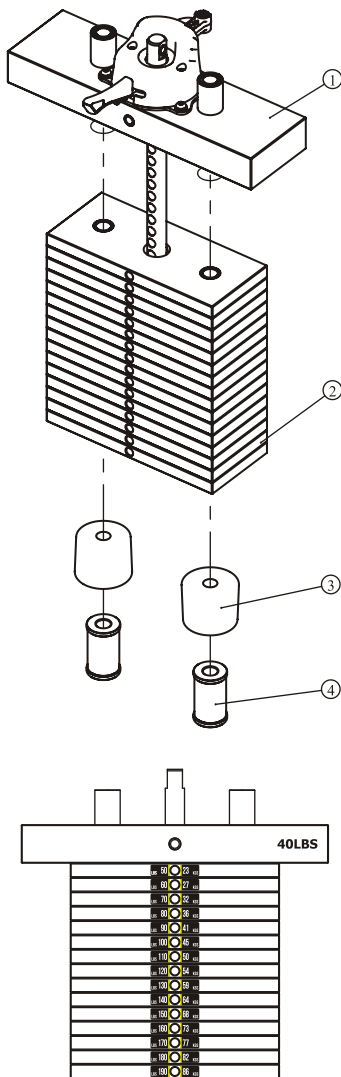

50-190LBS

LBS 20	9	KGS
LBS 30	14	KGS
LBS 40	18	KGS
LBS 50	23	KGS
LBS 60	27	KGS
LBS 70	32	KGS
LBS 80	36	KGS
LBS 90	41	KGS
LBS 100	45	KGS
LBS 110	50	KGS
LBS 120	54	KGS
LBS 130	59	KGS
LBS 140	64	KGS
LBS 150	68	KGS
LBS 160	73	KGS
LBS 170	77	KGS
LBS 180	82	KGS
LBS 190	86	KGS
LBS 200	91	KGS
LBS 210	95	KGS
LBS 220	100	KGS
LBS 230	104	KGS

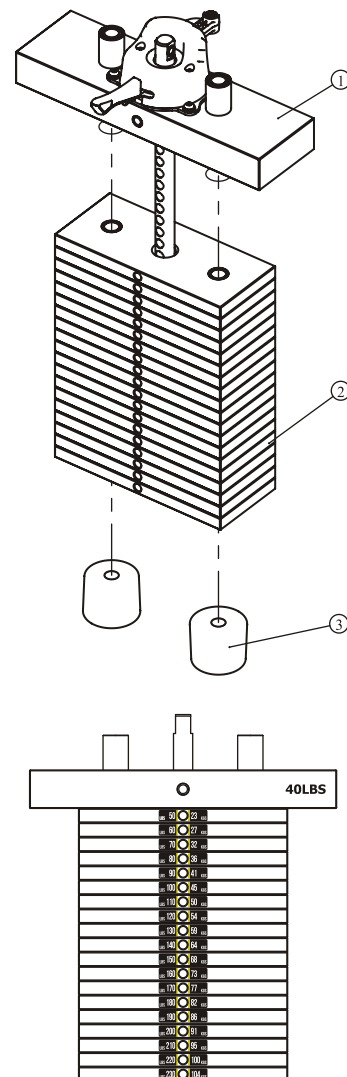

50-230LBS

Weight plate sticker paste schematic diagram

**Note: 30LBS weight are used the function of balance.**

# Assembly

Please assemble according to the actual **Weights** you buy !

## 15LBS×15PCS

## 15LBS×19PCS

Grade No.	Part No.	Description	QTY	Grade No.	Part No.	Description	QTY
1	FE970230ASSY	40LBS Top Plate ASSY	1	1	FE970230ASSY	40LBS Top Plate ASSY	1
2	FE97193200	15LBS Weight Plate	15	2	FE97193200	15LBS Weight Plate	19
3	IN-D10132900	Weight Rubber Bumpers	2	3	IN-D10132900	Weight Rubber Bumpers	2
4	FEWS01ASSY	Weight Stack Space	2				

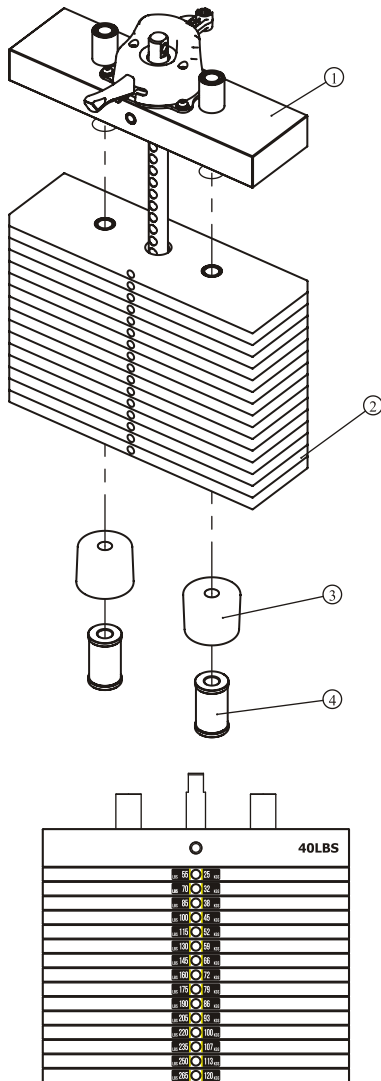

55-265LBS

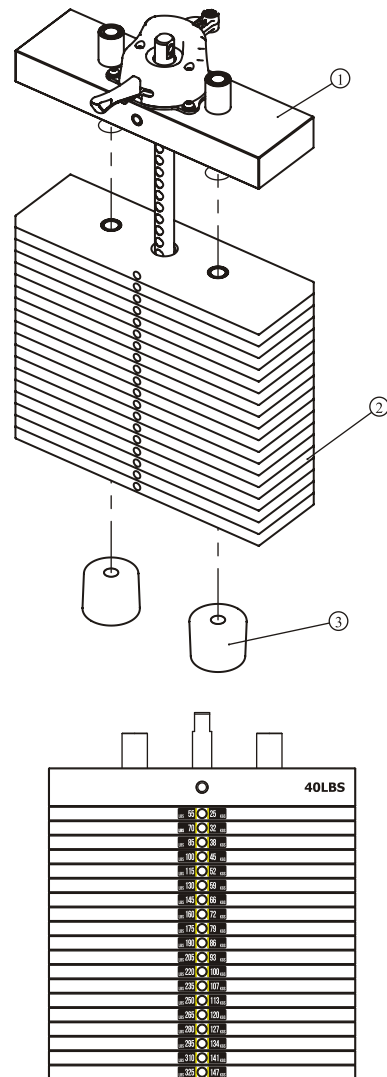

55-325LBS

Weight plate sticker paste schematic diagram

**Note: 30LBS weight are used the function of balance.**

# Assembly

## STEP 5

1. Attach one end of The Belt ASSY (#11) to The Weight Stack Frame ASSY (#1) using:  
one  $\Phi 13 \times \Phi 24 \times 2.5$  Flat Washer (#71)      one M12 Nylon Lock Nut (#76)
2. Attach the other end of The Belt ASSY (#11) through The Moving Block ASSY (#9), and assemble The  $\Phi 76$  Narrow Belt Pulley (#10) to The Moving Block ASSY (#9) using:  
one M10\*65 SHCS (#54)      two  $\Phi 11 \times \Phi 20 \times 2$  Flat Washers (#70)  
one M10 Nylon Lock Nut (#75)  
And through two Belt Pulleys on the Weight Stack Frame ASSY (#1).
3. Attach the other end of The Belt ASSY (#11) to the Top Plate ASSY (#30) using:  
one M10\*45 SHCS (#53)      two  $\Phi 11 \times \Phi 20 \times 2$  Flat Washers (#70)  
one M10 Nylon Lock Nut (#75)  
Attach two  $\Phi 17 \times 49$  Belt Rubber Sleeves (#42) to The Weight Stack Frame ASSY (#1) using:  
two  $\Phi 15 \times \Phi 8 \times 65.5$  Spacer Pins (#46)      two  $\Phi 6$  Shaft Ring Opening (#77)
4. Attach the Cable Connector (#49) to the Weight Stack Frame ASSY (#1) using:  
one M10\*45 SHCS (#53)      two  $\Phi 11 \times \Phi 20 \times 2$  Flat Washers (#70)  
one M10 Nylon Lock Nut (#75)
5. Attach the 4.5" Pulleys (#24) to the Main Frame ASSY (#2).
6. Attach The Cable ASSY (#12) to Cable Connector (#49).  
And attach the other end of The Cable (#12) through three 4.5" Pulley to The Main Frame ASSY (#2) using:  
one Pulleys Spacer 2  $\Phi 22 \times \Phi 17.5 \times 7.5$  (#48)      one  $\Phi 11 \times \Phi 20 \times 2$  Flat Washers (#70)  
one M10\*25 SHCS (#52)      one Joint Bearing (#52)  
one Ring  $\Phi 18 \times \Phi 12.3 \times 4$  (#51)      one Flat Washer  $\Phi 13 \times \Phi 24 \times 2.5$  (#71)  
one M12\*35 SHCS (#56)      one Cover Plate (#22)

**Note: Wrench Tighten Bolts and Nylon Lock Nuts.**

## Step 6

1. Attach The Back Lower Cover (#34) to The Weight Stack Frame ASSY (#1) using:  
three M6\*20 BHCS (#67)      three  $\Phi 6.6 \times \Phi 12 \times 1.6$  Flat Washers (#68)
2. Attach two Front Shroud (#32) to The Front Lower Cover (#31) on The Weight Stack Frame ASSY (#1).
3. Assemble The Console PCB, and attach The Training Placard Cover ASSY (#35) to The Weight Stack Frame ASSY (#1) using:  
four M6\*15 BHCS (#66)      four  $\Phi 6.6 \times \Phi 12 \times 1.6$  Flat Washers (#68)
4. Attach The Back Shroud (#33) to The Back Lower Cover (#34) and The Weight Stack Frame ASSY (#1) using:  
two M6\*20 BHCS (#67)      two  $\Phi 6.6 \times \Phi 12 \times 1.6$  Flat Washers (#68)
5. Attach The Top Cover (#18) to The Weight Stack Frame ASSY (#1) using:  
two M6\*20 BHCS (#67)      two  $\Phi 6.6 \times \Phi 12 \times 1.6$  Flat Washers (#68)
6. Attach the Footrest Frame ASSY (#6) to The Main Frame ASSY (#2) using:  
three M10\*25 SHCS (#52)      three  $\Phi 11 \times \Phi 20 \times 2$  Flat Washers (#70)
7. Attach the Cover Plate (#23) to The Footrest Frame ASSY (#6) using:  
three M6\*12 BHCS (#65)

**Note: Wrench Tighten Bolts.**

# Assembly

## STEP 5

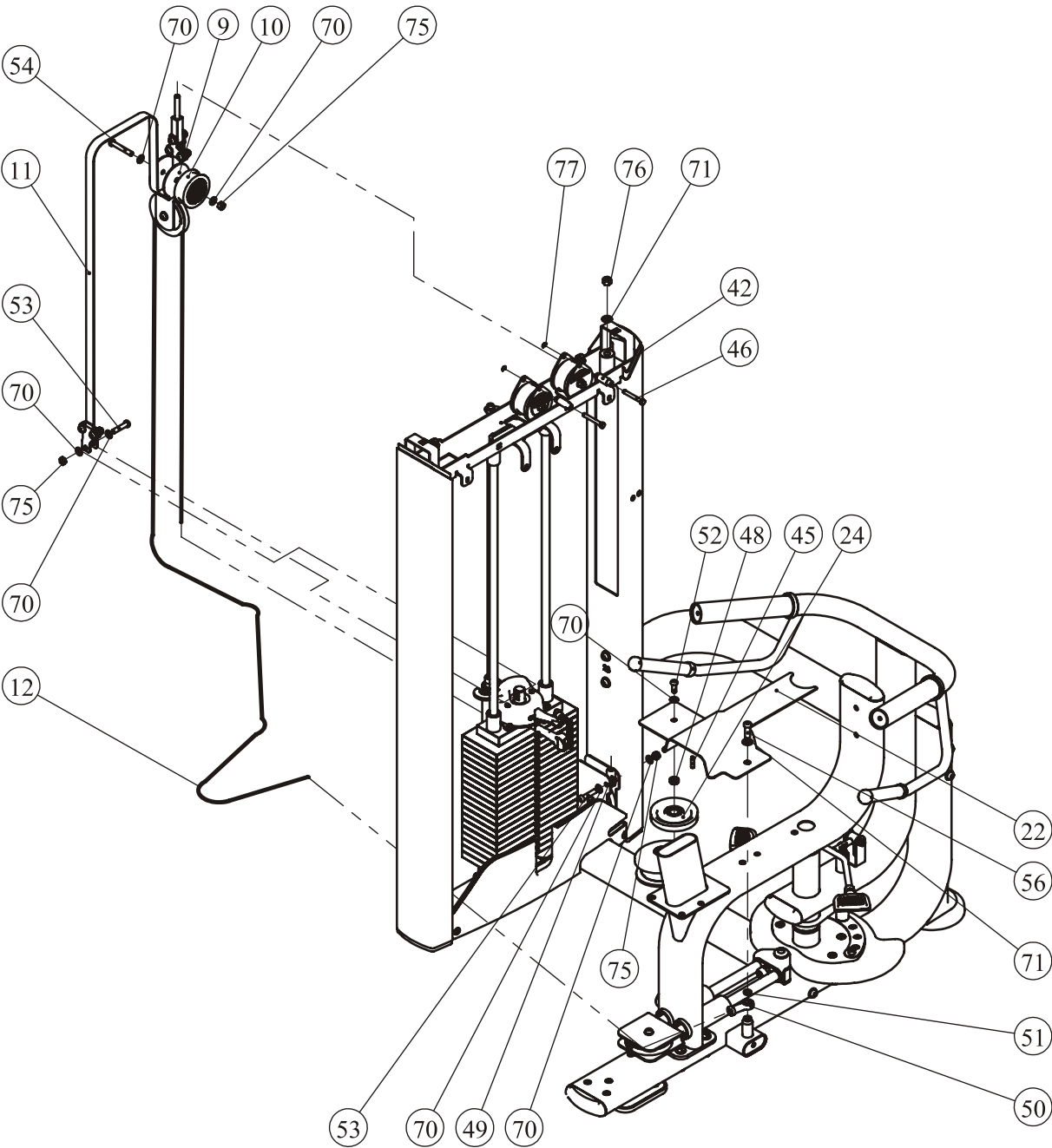

# Assembly

## STEP 6

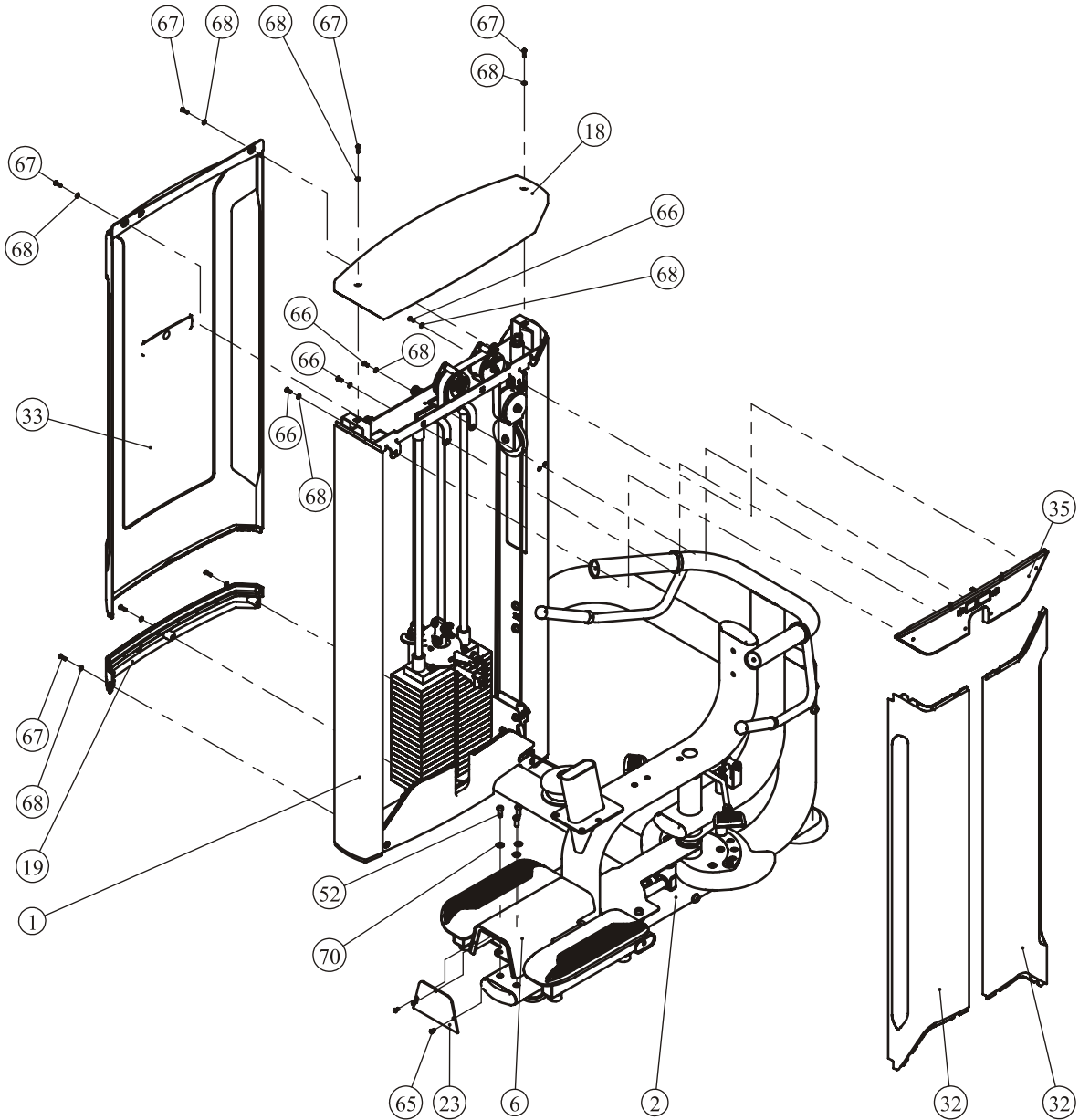
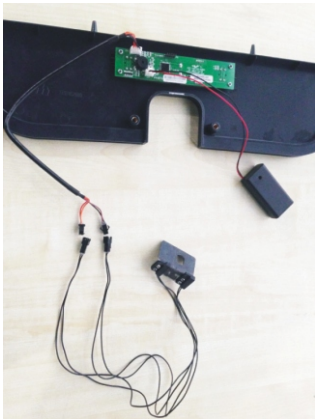
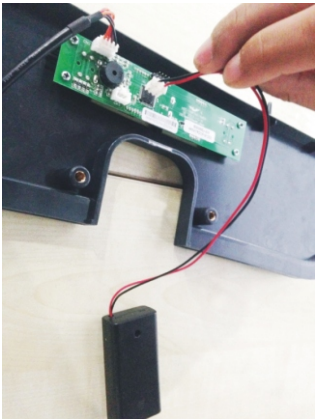





# Adjust Instructions

## The use of Selector Pin W/Coil

1. Select an appropriate weight and put the Selector Pin W/Coil into the hole on it.
2. Make sure the Selector Pin W/Coil gets into the hole completely.

## The Wriggled Frame ASSY adjustment

1. Pull out the Regulation Handle Frame ASSY and adjust the Foam Frame to the desired position.
2. Make sure the pin gets into the hole completely.

## The 5LBS Counter Weight adjustment

1. Toggle the Shifting Fork to the desired position.
2. Make sure the Shifting Fork gets into the Fillister completely.

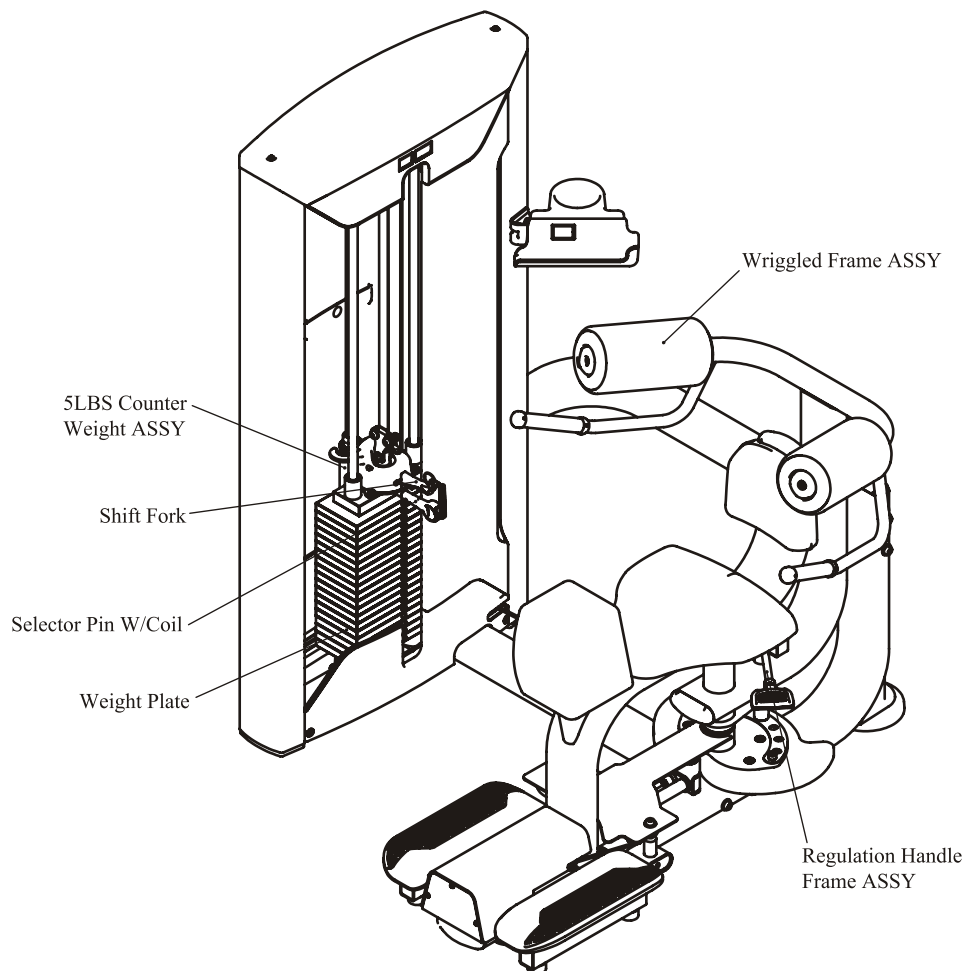

# Exercise Instructions

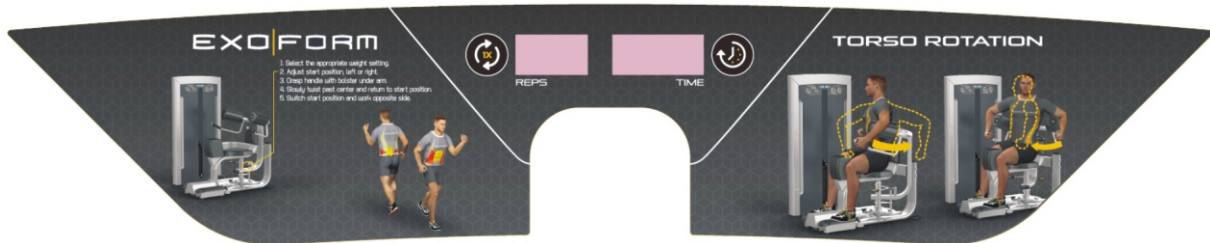

# Console Panel Function



## 1. CONSOLE PANEL FUNCTION

### 1.1 TIME WINDOW

Indicates elapsed time after pressing start in minutes and seconds (0-99minutes, 0-59seconds).

### 1.2 REPS WINDOW

Indicates times of workout cycle (0-999).

## 2. BUTTONS

2.1 REPS RESET: Reset value of REPS window.

2.2 TIME RESET: Reset value of TIME window

## 3. SAVE POWER MODE

3.1 Switched on automatically when there is signal input.

3.2 The screen turn off of self after 3 minutes in stop station.

# Battery Replacement

## Battery replacement

For this computer you need 2 pcs. 1.5V AA batteries. If the display quality gets poor, you should replace the battery. Therefore please open the battery case cover on the back side of your computer and replace the old battery by a fitting new one. Close the case cover properly.



**You must check the batteries regularly to prevent leakage from damaging console.**

## Battery-Disposal

Batteries should not be considered as regular garbage. As consumer you are obliged to return finished batteries. The finished batteries can be returned to a collection base at your residential area or at places, where batteries can be bought.



**WE RECOMMEND THE USE OF ALCALI-MANGAN BATTERIES.**

You will find these symbols on batteries, which contain harmful substances:

Pb = Battery contains lead

Cd = Battery contains cadmium

Hg = Battery contains mercury



Pb



Cd



Hg

# Maintenance Schedule

ROUTINE	COMMERCIAL MAINTENANCE	HOME MAINTENANCE	LATEST DATE ENTRY						
Inspect; Links, Pull Pins, Snap Locks, Swivels, Weight Stack Pins	DAILY	WEEKLY							
Clean; Upholstery	DAILY	WEEKLY							
Inspect; Cables or Belts and their tension	DAILY	WEEKLY							
Inspect; Accessory Bars, and Handles	WEEKLY	3 MONTHS							
Inspect; All Decals	WEEKLY	3 MONTHS							
Inspect; All Nuts and Bolts, Tighten if needed	WEEKLY	3 MONTHS							
Inspect; Anti-Skid Surface	WEEKLY	3 MONTHS							
Clean & Lubricate; Guide Rods with a Teflon (PTFE) based lubricant (Superlube)	MONTHLY	3 MONTHS							
Lubricate; Seat Sleeves, Turcite Bushings, Linear Bearing	MONTHLY	3 MONTHS							
Clean and Wax; All Glossy Finishes	6 MONTHS	YEARLY							
Repack with Grease; Linear Bearings	6 MONTHS	YEARLY							
Replace; Cables, Belts and Connecting Parts	YEARLY	3 YEARS							

*Your equipment comes with a commercial maintenance decal. For personal, in home use, please follow the home maintenance schedule listed above.*

# General Maintenance Information

## **Links, Pull-Pins, Snap Hooks, Swivels, Weight Stack Pins:**

- \* Check all pieces for signs of visible wear or damage.
- \* Check springs in snap hooks and pull-pins for proper tension and alignment.
- \* If the spring sticks or has lost its rigidity, replace it immediately.

## **Upholstery:**

- \* To ensure prolonged upholstery life and proper hygiene, all upholstered pads should be wiped down with a damp cloth after every workout.
- \* Periodically take the time to use a mild soap or an approved vinyl upholstery cleaner to deter the onset of cracking or drying. Avoid using any abrasive cleaners or cleaners not intended for use on vinyl.
- \* Replace ripped or worn upholstery immediately.
- \* Keep sharp or pointed objects clear of all upholstery.

## **Decals:**

- \* Inspect and familiarize yourself with any safety warnings or other user information posted on each decal.

## **Nuts and Bolts:**

- \* Inspect all nuts and bolts for any loosening and tighten if needed.
- \* Go through a re-tightening sequence periodically to ensure that all hardware is tensioned proper.

## **Anti-Skid Surfaces:**

- \* These surfaces are designed to supply secure footing and need to be replaced if they appear worn or become slippery.

## **Belts and Cables:**

- \* We use only high quality belt, and mil-spec cables.
- \* Visually inspect the belts and cables for fraying, cracking, peeling or discoloration.
- \* While the machine is not in use, carefully run your fingers along the belt or cable to feel for thinning or bulging areas.
- \* Replace belts and cables immediately at the first signs of damage or wear. Do not use equipment until belts or cables have been replaced.

## **Belt and Cable Tension:**

- \* Referring to the Owners Manual, when belts or cables are used check all bolts attachments to be sure they are properly attached.
- \* Check slack in cables and re-adjust cable tension if needed.

## **Seat Sleeves, Guide Rods:**

- \* Wipe down adjusting tubes with a dust free rag before applying lubricant.
- \* Lubricate seat sleeves and Guide Rods with a Silicon or Teflon based lubricant spray.

## **Linear Bearings:**

- \* Referring to the Owners Manual carefully disassemble the bearing from its housing and place a finger full of light grease (lithium, super lube, etc.) into the inside of the bearing. Using your finger, press the grease into the ball-bearings and their tracks. Repeat until the ball-bearing tracks are full of grease. Insert the shaft back into the bearing and wipe off excess grease.

**PLEASE KEEP THIS FOR YOUR RECORDS**

## Weight Training Tips

Use this manual to guide you through the basic exercises you can perform on your equipment. To gain maximum results and avoid possible injury, consult a fitness professional to develop your complete exercise program.

Always consult your physician before starting any exercise program.

To be successful in your exercise program, it is important to develop an understanding of the basic principles of strength training. Now that you have your equipment, it is only natural that you want to get started immediately. First, determine a set of realistic goals and objectives for yourself. By deciding on an exercise plan that is right for you prior to starting, you will contribute significantly to your success.

Warm up properly before engaging in weight resistance training. Stretching, yoga, jogging, calisthenics or other cardiovascular exercise can help prepare your body for the heavier workload of lifting weights.

Learn how to perform the exercise correctly before using heavy weight. Correct form is important to avoid injury and to ensure that you work the proper muscle groups.

Know your limitations. If you are new to weight training or are embarking on an exercise regimen after a long layoff, start slowly and build foundational strength over a longer period of time.

Pay attention to your breathing. Exhale when you exert is a general rule of thumb. Never hold your breath.

