

The composing of accessories

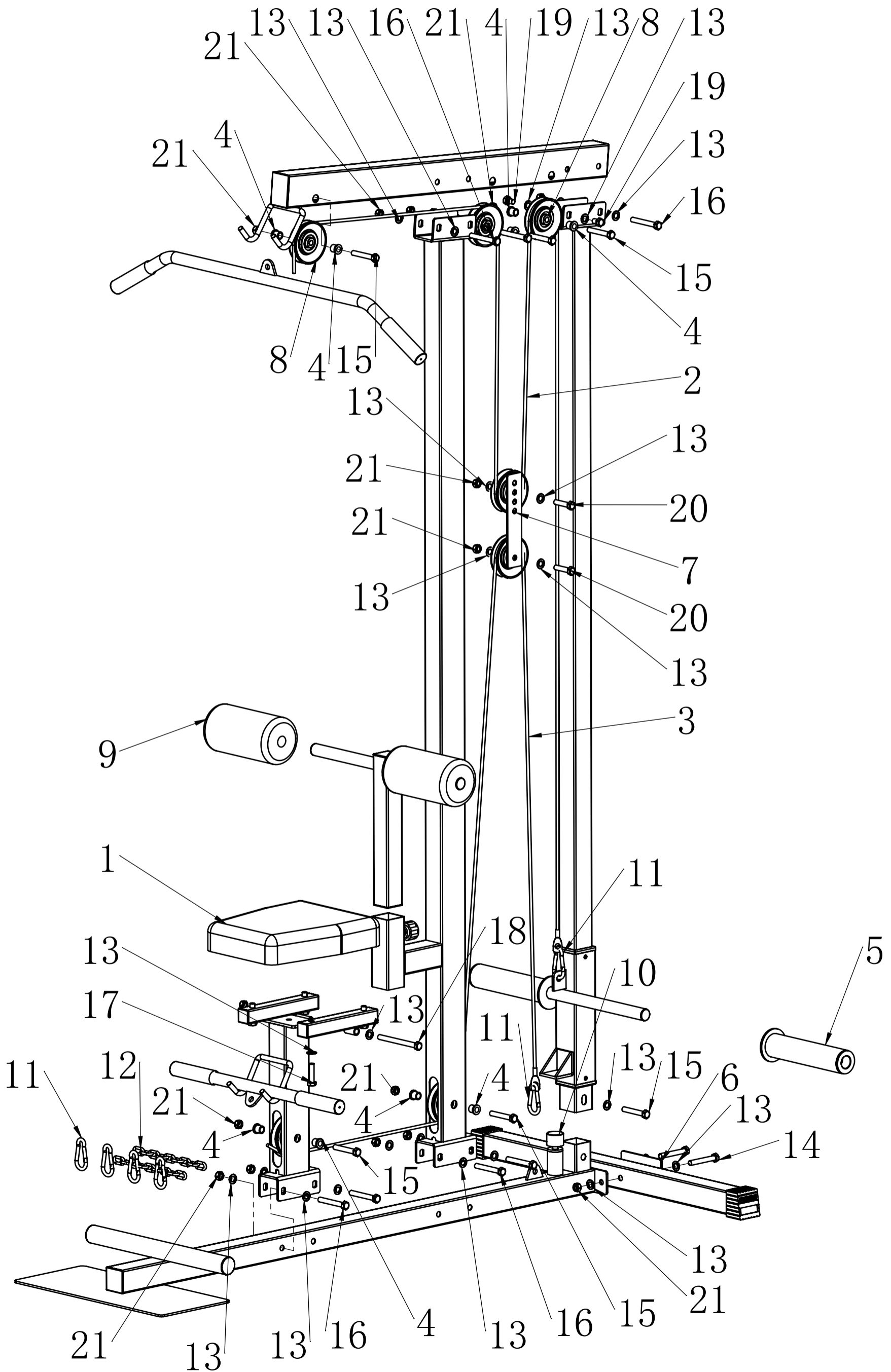

The composing of accessories

PART NO.	DESCRIPTION	QTY
1	Pad	1
2	1#Rope 3660mm	1
3	1#Rope 2980mm	1
4	Bushing	10
5	OP casing	2
6	Plate	1
7	Pulley Plate	2
8	Pulley 90mm	7
9	Foam	2
10	Plastic pad	1
11	Buckle	6
12	Chain ϕ 5X200	2
13	M10 Washer	32
14	M10X70 Hex Bolt	2
15	M10X65 Hex Bolt	6
16	M10X75 Hex Bolt	7
17	M10X40 Hex Bolt	4
18	M10X115 Hex Bolt	1
19	M10X16 Hex Bolt	2
20	M10X45 Hex Bolt	2
21	M10 Nylon Nut	18

Note:

1. Assemble in place according to the drawing, first assemble and then tighten. All screws are installed according to the graphic position.

Each screw has two gaskets and one nut.

2. The wire rope should be threaded in accordance with the explosion diagram. It should not be crossed or reversed.

3. Bushings should be added to the round holes on both sides of the connection between pulley and pipe.